

Component	Description	Part Number
REF SCHEMATIC	BOARD, PC, OPTIC DETECTOR, REV A	753 062 11
REF RAW	BOARD, PC, OPTIC DETECTOR, REV A	753 062 31
REF DRAWING	BOARD, PC, OPTIC DETECTOR, REV A	753 062 52
REF SUB ASSEMBLY/LIST	BOARD, PC, OPTIC DETECTOR, REV A	753 062 43
J105	CONNECTOR, HDR, 5 PIN, 2.5MM RTA, AMP	211 321 90
Q1,2	PHOTOTRANSISTOR, DARL, PLASTIC, QSD733	373 029 90
S1	SWITCH, PC MT, MICROMINI, PB, 1A	510 141 90

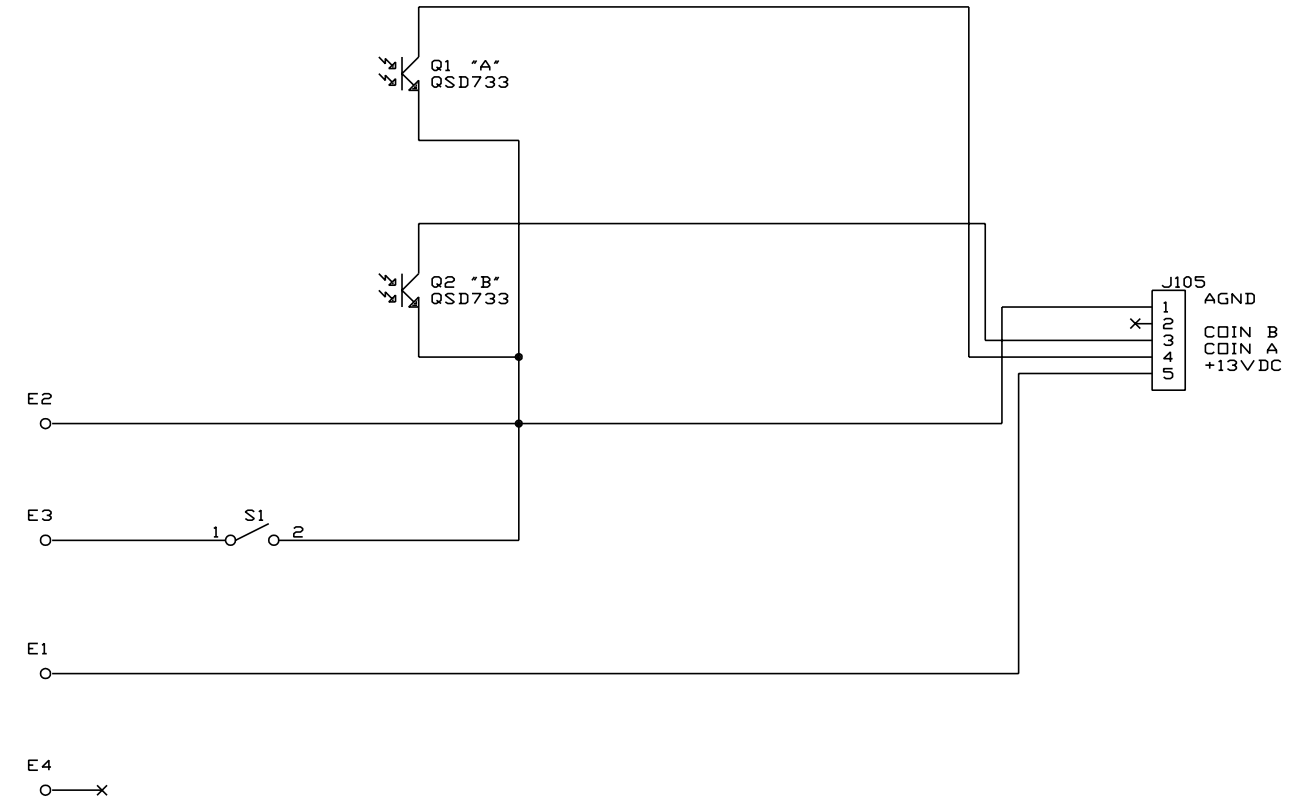
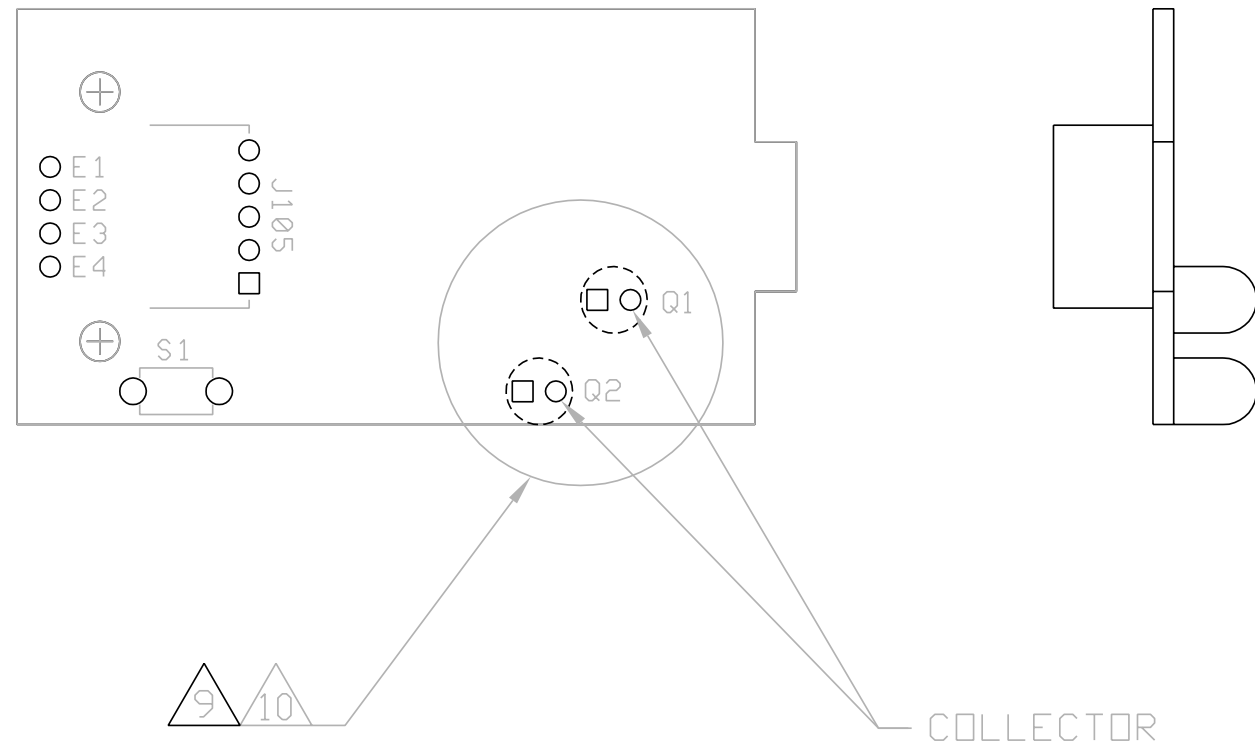

9 DO NOT ALLOW OPTICAL DEVICES TO COME IN CONTACT WITH ANY CHEMICALS WHICH COULD ALTER THEIR OPTICAL CHARACTERISTICS. SOLDERING MUST BE DONE WITH "HALIDE FREE" NON-CORROSIVE FLUXES. FOR HAND SOLDERING, ACCEPTABLE WIRE SOLDER IS "MULTICORE" P/N SN63X398-.022. FOR WAVE AND SURFACE MOUNT SOLDERING, SELECT A FLUX THAT IS SUITED TO THE TOTAL SOLDERING PROCESS, AND HAS A HALIDE CONTENT LISTED AS NONE.

10 SEE IGT SPECIFICATION DRAWING #37302990 FOR COMPONENT MANUFACTURE'S COLLECTOR MARKING.