

<i>TOVIS</i>	TOVIS P/N	MTG-1972XN	DATE	03/11/02
	IGT P/N	69925100	REV NO.	0
			PAGE	1/30

**Color Monitor Service Manual
MODEL: MTG – 1972XN
(FOR IGT AUSTRALIA)**



<i>TOVIS</i>	TOVIS P/N	MTG-1972XN	DATE	2002.03.11
		Color Monitor Service Manual	REV NO.	0
			PAGE	2/30

I N D E X

1. SAFETY PRECAUTIONS -----	3
2. SPECIFICATIONS -----	4
3. TECHNICAL FEATURES -----	5
4. TIMING CHART -----	6
5. SET UP -----	8
6. CONTROLS AND ADJUSTMENTS -----	9
7. ADJUSTMENT SPECIFICATION -----	18
8. DESCRIPTION OF CIRCUIT OPERATION -----	21
9. TROUBLE SHOOTING -----	25

TOVIS	TOVIS P/N	MTG-1972XN	DATE	2002.03.11
		Color Monitor Service Manual	REV NO.	0
			PAGE	3/30

1. SAFETY PRECAUTIONS

WARNING: Service should not be attempted by anyone unfamiliar with the necessary precautions on this unit. The following precautions are necessary during servicing.

- 1-1. Some parts in this unit, such as a picture tube, have special safety-related Characteristics for X-RAY RADIATION protect.
For continued safety, the parts replacement should be undertaken referring to below article(1-2 ~ 1-5).

- 1-2. Many electrical mechanical parts in this unit have special safety-related characteristics for protection against shock hazard and others.
These characteristics are often passed unnoticed by a visual inspection and the protection afforded by them cannot necessarily be obtained by using replacement components rated for higher voltage wattage, etc.
Replacement parts, which have these special characteristics, are identified in the manual and supplements by shading on the schematic diagram and the parts list. Before replacing these components read the parts list in this manual carefully.

- 1-3. When replacing the chassis in the cabinet, always be certain that all the protective devices are installed properly, such as insulating covers, strain relief, etc.

- 1-4. Before replacing the back cover of the set, thoroughly inspect inside the cabinet to see that no stray parts or tools have been left inside.

- 1-5 Before returning the set to the customer always perform an ac current leakage check on the exposed metallic parts of the cabinet, such as terminal, screw heads, metal overlays, control shafts, etc. To be sure the set is safe to operate without danger of electrical shock, plug the AC line cord directly into a 115V AC outlet (do not use a line isolation transformer during this check). Use an AC volt- meter having 5000 ohms per volt or more sensitivity in the following manner. Cannot use a 1500 ohm, 10watt resistor, paralleled by a 0.15(uF) capacitor. Reverse the AC plug in the AC outlet and repeat AC voltage measurements for each exposed metallic part. Voltage measured must not exceed 0.3V RMS. This corresponds to 0.2mA AC any value exceeding this limit constitutes a potential shock hazard and must be corrected immediately.

TOVIS	TOVIS P/N	MTG-1972XN	DATE	2002.03.11
		Color Monitor Service Manual	REV NO.	0
			PAGE	4/30

2. SPECIFICATIONS

2-1. Picture Tube

- Size : 19"
- Dot Pitch : 0.25mm

2-2. Signal Input

- Video Input : Analog, Positive Signal(0.7Vp-p)
- Horizontal Sync : TTL Level, Positive or Negative pulse.
- Scanning : 28Khz ~ 70KHz
- Vertical Input : TTL Level, Positive or Negative pulse.
- Scanning : 40~ 160Hz

2-3. Power Supply

- Power Input : AC100~ 240V, 60/50Hz
- Fuse Rating : 250V, 50T 3.15A
- Power Consumption
 - Normal: less than 130W
 - DPMS: less than 20W

2-4. External Control:

Refer to page 7.

2-5. Operating Temperature: 0°C~ 55°C

2-6. Operating Humidity: 10%~ 90%(Non-condensing)

2-7. Net weight: 23kg

TOVIS	TOVIS P/N	MTG-1972XN	DATE	2002.03.11
		Color Monitor Service Manual	REV NO.	0
			PAGE	5/30

3. TECHNICAL FEATURES.

3-1. U-com(MCU) control with OSD.

U-com recognizes the computer signal and the signal output from control board connected with wire. So the circuit is simplified.

3-2. Universal AC input voltage.

Power supply operates on AC100~ 240volt 60/50Hz for use all over the world.

3-3. Protection Circuit for over-current.

When over-current happens in the circuit, the protection circuit operates in order to prevent the components from electrical shock or other risks.

3-4. Override function

Is designed for the normal display when the monitor is powered on without connection from the source (No signal message).

3-5. Control panel

If you are not satisfied with the factory mode size, position, color settings, use the control panel to program those you prefer in each resolution mode.

Then, these adjusted settings are kept in memory even if you change resolution mode or turn off the monitor.

3-6. I²C BUS control

It is designed by I²C BUS control for simplifying the circuit. The number of total components is less than 610 pcs.

TOVIS	TOVIS P/N	MTG-1972XN	DATE	2002.03.11
		Color Monitor Service Manual	REV NO.	0
			PAGE	6/30

4. TIMING CHART

Factory Pre-Set Timing Modes.

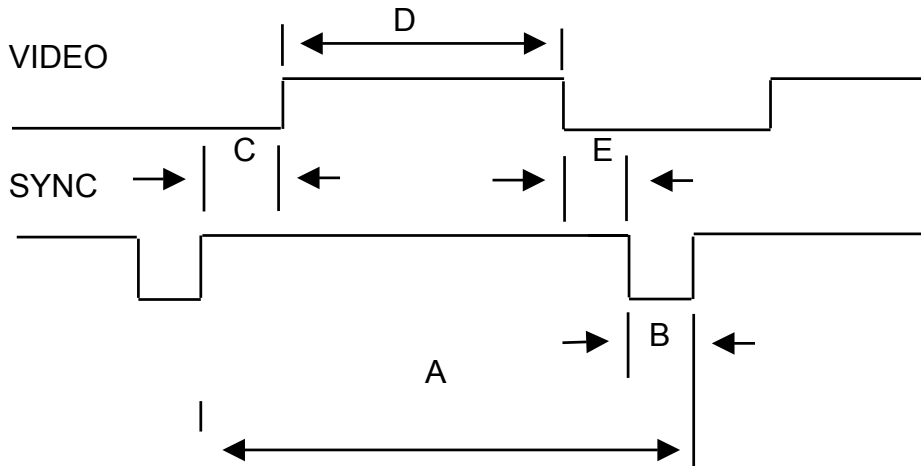

DESCRIPTION		MODE 1 VGA 720*400	MODE 2 VGA 640*480	MODE 3 8514/A 1024*768	MODE 4 S-VGA 680*400
H	FH	31.469KHz	31.469KHz	35.552KHz	37.500KHz
	A	31.778μs	31.778μs	28.251μs	26.667μs
	B	3.813μs	3.813μs	3.920μs	2.032μs
	C	1.907μs	1.589μs	1.247μs	3.810μs
	D	25.422μs	25.422μs	22.806μs	20.317μs
	E	0.636μs	0.318μs	0.170μs	0.508μs
	POL.	NEGATIVE	NEGATIVE	POSITIVE	NEGATIVE
V	FH	70.087Hz	59.940Hz	86.960KHz	75.000Hz
	A	14.268ms	16.683ms	11.500ms	13.333ms
	B	0.064ms	0.064ms	0.113ms	0.080ms
	C	1.112ms	0.794ms	0.563ms	0.427ms
	D	12.711ms	15.253ms	10.810ms	12.800ms
	E	0.381ms	0.064ms	0.014ms	0.027ms
	POL.	POSITIVE	NEGATIVE	POSITIVE	NEGATIVE
VIDEO	ANALOG	ANALOG	ANALOG	ANALOG	

TOVIS	TOVIS P/N	MTG-1972XN	DATE	2002.03.11
		Color Monitor Service Manual	REV NO.	0
			PAGE	7/30

DESCRIPTION		MODE5 S-VGA VESA 800*600	MODE6 VGA 800*600	MODE 7 VGA VESA 800*600	MODE 8 VESA 1024*768
H	FH	37.879KHz	46.875KHz	48.077KHz	48.363KHz
	A	26.400μs	21.333μs	20.800μs	20.677μs
	B	3.200μs	1.616μs	2.400μs	2.231μs
	C	2.200μs	3.232μs	1.280μs	1.615μs
	D	20.000μs	16.162μs	16.000μs	15.754μs
	E	1.000μs	0.323μs	1.119μs	0.998μs
	POL.	POSITIVE	POSITIVE	POSITIVE	NEGATIVE
V	FV	60.317Hz	75.000Hz	72.188Hz	60.004Hz
	A	16.579ms	13.333ms	13.853ms	16.666ms
	B	0.106ms	0.064ms	0.125ms	0.124ms
	C	0.607ms	0.448ms	0.478ms	0.600ms
	D	15.840ms	12.800ms	12.480ms	15.880ms
	E	0.026ms	0.021ms	0.772ms	0.062ms
	POL.	POSITIVE	POSITIVE	POSITIVE	NEGATIVE
VIDEO	ANALOG	ANALOG	ANALOG	ANALOG	

TOVIS	TOVIS P/N	MTG-1972XN	DATE	2002.03.11
		Color Monitor Service Manual	REV NO.	0
			PAGE	8/30

DESCRIPTION		MODE 9 VESA 800*600	MODE 10 VESA 1024*768	MODE 11 VESA 1024*768	MODE 12 VESA 1280*1024	MODE 13 VESA 1024*768
H	FH	53.674KHz	56.476KHz	60.023KHz	63.981KHz	68.677KHz
	A	18.631μs	17.707μs	16.660μs	15.698μs	14.561μs
	B	1.138μs	1.813μs	1.219μs	1.037μs	1.016μs
	C	2.702μs	1.920μs	2.235μs	2.296μs	2.201μs
	D	14.222μs	13.653μs	13.003μs	11.852μs	10.836μs
	E	0.569μs	0.321μs	0.203μs	0.360μs	0.508μs
	POL.	POSITIVE	NEGATIVE	POSITIVE	POSITIVE	POSITIVE
V	FV	85.062Hz	70.069Hz	75.029Hz	60.020Hz	84.997Hz
	A	11.756ms	14.272ms	13.328ms	16.638ms	11.765ms
	B	0.056ms	0.106ms	0.050ms	0.047ms	0.044ms
	C	0.503ms	0.513ms	0.466ms	0.594ms	0.524ms
	D	11.179ms	13.599ms	12.795ms	16.005ms	11.183ms
	E	0.019ms	0.054ms	0.017ms	0.016ms	0.015ms
	POL.	POSITIVE	NEGATIVE	POSITIVE	POSITIVE	POSITIVE
VIDEO	ANALOG	ANALOG	ANALOG	ANALOG	ANALOG	

5. SET UP

Setting up your monitor is easy. All you have to do is make a few simple connections and adjustments. The procedure is as follows.

5-1. Start Up

Your monitor starts up automatically when you insert the power plug to power source.

5-2. Signal cable Connection

Connect the 15pin-signal cable to the source. And Lock both screws to ensure that the monitor is properly grounded.

TOVIS	TOVIS P/N	MTG-1972XN	DATE	2002.03.11
		Color Monitor Service Manual	REV NO.	0
			PAGE	9/30

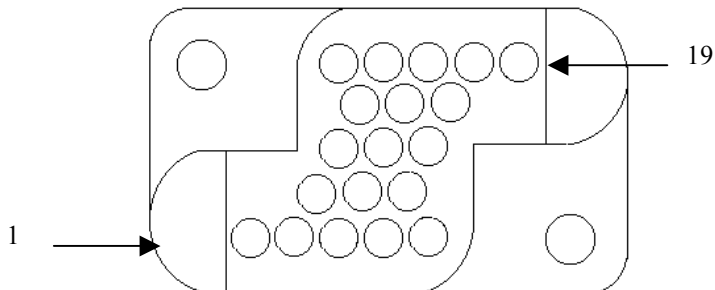

AMP 19pin connector

NO.	DESCRIPTION	NO.	DESCRIPTION
1		11	TOUCH_RxD
2	VIDEO RED	12	NET GND
3	VIDEO BLUE	13	AC GND
4	VIDEO GREEN	14	AC2
5	HOR-SYNC	15	AC1
6	VER-SYNC	16	A GND
7	VIDEO GND	17	+13V DC(A)
8		18	AC2
9	TOUCH_TxD	19	AC1
10			

6. CONTROLS AND ADJUSTMENTS

There are four switches on the control panel.

Adjustable controls allow the best display status for individual preferences.

6-1. Key Function

① MODE

MODE - Call the Main-Menu OSD.

② SEL/DEGAUSS

SEL – Select the function (sub-Menu OSD) on the Main- Menu OSD.

DEGAUSS – Do degaussing in state that the OSD isn't displayed.

③ DOWN/UP

-When the Main-Menu is displayed, can search each function using these Keys.

-When the Sub-Menu is displayed (after select the function), can change each state of the screen using these keys.

TOVIS	TOVIS P/N	MTG-1972XN	DATE	2002.03.11
		Color Monitor Service Manual	REV NO.	0
			PAGE	10/30

O.S.D Control Sub-P.C.B

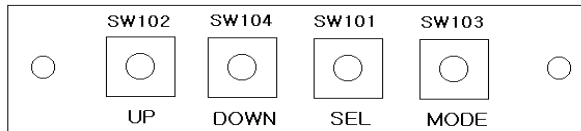

6.2. O.S.D CONTROL METHOD

1) Control items.

Location	Adjustment Method	Function
SUB PCB	OSD Control	Brightness Contrast Horizontal Position Horizontal-Size Vertical Position Vertical-Size Side Pincushion Trapezoid Pin Balance Parallelogram
MAIN PCB	VR control, VR501 VR301 FBT	Sub-Bright H.V Adjustment Focus and Screen

6-3. OSD Controls

- User's control.

A. BRIGHTNESS ADJUSTMENT.

- 1) Press the "MODE" key then Main-Menu OSD come out as below Figure.
- 2) Search "BRIGHTNESS" sub-menu using "UP/DOWN" key on the Main-Menu OSD.
- 3) Select the "BRIGHTNESS" by pressing "SEL" key. Then The "BRIGHTNESS" OSD color changes from yellow to red.

TOVIS	TOVIS P/N	MTG-1972XN	DATE	2002.03.11
		Color Monitor Service Manual	REV NO.	0
			PAGE	11/30

- 4) Adjust Brightness as much as you want using “UP/DOWN” key.
- 5) After finishing the Brightness adjustment, Press the “MODE” key then
The “BRIGHTNESS” OSD color changes from red to yellow and the changed brightness value is saved automatically.
- 6) If you want to adjust other functions (sub-menu), Search your Sub-menu
example: “CONTRAST” using “UP/DOWN” keys and then adjust the same
way as item 3),4) and 5).
- 7) Press the “MODE” key again to finish the adjustment then the OSD menu
will disappear.

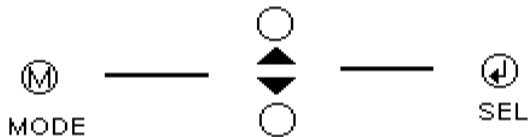

☀ BRIGHTNESS	██████████	50
🟡 CONTRAST	██████████	Max
📏 H.POSITION	██████████	50
📏 H.SIZE	██████████	50
📏 V.POSITION	██████████	50
📏 V.SIZE	██████████	50
📏 PINCUSHION	██████████	50
📏 TRAPEZOID	██████████	50
📏 PARALLELOG	██████████	50
📏 PIN BALANCE	██████████	50
👁 COLOR		
📺 RECALL		
🗨 LANGUAGE		
800X600 75Hz/46.8KHz		

☀ BRIGHTNESS	██████████	50
🟡 CONTRAST	██████████	Max
📏 H.POSITION	██████████	50
📏 H.SIZE	██████████	50
📏 V.POSITION	██████████	50
📏 V.SIZE	██████████	50
📏 PINCUSHION	██████████	50
📏 TRAPEZOID	██████████	50
📏 PARALLELOG	██████████	50
📏 PIN BALANCE	██████████	50
👁 COLOR		
📺 RECALL		
🗨 LANGUAGE		
800X600 75Hz/46.8KHz		

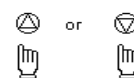

TOVIS	TOVIS P/N	MTG-1972XN	DATE	2002.03.11
		Color Monitor Service Manual	REV NO.	0
			PAGE	12/30

- B. CONTRAST ADJUST SAME WAY AS ABOVE
- C. H. POSITION ADJUST SAME WAY AS ABOVE
- D. H. SIZE ADJUST SAME WAY AS ABOVE
- E. V. POSITION ADJUST SAME WAY AS ABOVE
- F. V. SIZE ADJUST SAME WAY AS ABOVE
- G. PINCUSHION ADJUST SAME WAY AS ABOVE
- H. TRAPEZOID ADJUST SAME WAY AS ABOVE
- I. PARALLELOG ADJUST SAME WAY AS ABOVE
- J. PIN BALANCE ADJUST SAME WAY AS ABOVE

K. COLOR ADJUSTMENT.

1) Press the "MODE" key then Main-Menu OSD come out as left below figure.

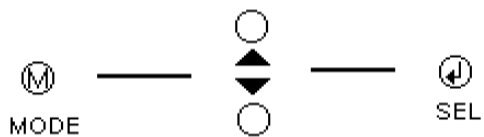

COLOR1	COLOR2	USER
RED		50
GRE		50
BLU		50

	BRIGHTNESS		50
	CONTRAST		Max
	H.POSITION		50
	H.SIZE		50
	V.POSITION		50
	V.SIZE		50
	PINCUSHION		50
	TRAPEZOID		50
	PARALLELOG		50
	PIN BALANCE		50
	COLOR		
	RECALL		
	LANGUAGE		
800X600 75Hz/46.8KHz			

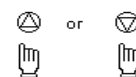

min->1-99->max

TOVIS	TOVIS P/N	MTG-1972XN	DATE	2002.03.11
		Color Monitor Service Manual	REV NO.	0
			PAGE	13/30

- 2) Search "COLOR" sub-menu using "UP/DOWN" key on the Main-Menu OSD.
- 3) Select the "COLOR" by pressing "SEL" key. Then the color Sub-Menu OSD comes out as right below figure.
- 4) Search "USER" using "UP/DOWN" key ("COLOR1" and "COLOR2" is adjusted in factory by an auto-alignment machine.)
- 5) Press "SELECT" key to adjust "RED", "GREEN" and "BLUE"
"RED", "GREEN" and "BLUE" is selected by pressing the "SELECT" key and selected item changes OSD color from white to it's corresponding color (ex: "RED" goes to red color)
- 6) Adjust "RED", "GREEN" or "BLUE" using "UP/DOWN" key.
- 7) Press "MODE" key to finish the color adjustment then the OSD goes back to Main-Menu.
- 8) Press the "MODE" key again to finish the adjustment then the OSD will disappear.

L. RECALL.

When the "RECALL" key is selected adjusted values are erased and replaced by the factory adjustment values.
At first without any user's adjustment, the monitor has a factory set up.

M. LANGUAGE.

There are 4 languages provided for ease of use.
(Factory setting is English)

- 2) Press the "MODE" key then Main-Menu OSD comes up.
- 3) Search "LANGUAGE" sub-menu using "UP/DOWN" key on the Main-Menu OSD.
- 4) Select the "LANGUAGE" by pressing "SEL" key. Then The Language sub-menu comes up as below figure.

TOVIS	TOVIS P/N	MTG-1972XN	DATE	2002.03.11
		Color Monitor Service Manual	REV NO.	0
			PAGE	14/30

- 4) Search any language using “UP/DOWN” key.
- 5) Select a language by pressing the “SEL” key.
- 6) Press “MODE” key to finish and save the selected language.
Then the OSD return to Main-Menu in selected language.
- 7) Press the “MODE” key again to finish the adjustment then the OSD will disappear.

LANGUAGE
ENGLISH
FRANCAIS
ESPANOL
PORTUGUES

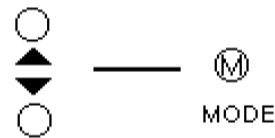

- Factory control.

This monitor has two-adjustment modes.

One is for the user’s own adjustments and other is for factory adjustments only.























Factory adjustments may be required during repair. Incorrect factory adjustments may adversely affect the user adjustment mode. Any factory adjustment errors can be recovered using the “RECALL” function (refer to 6-3 M item)

A. Factory mode entering.

Press the “MODE” and “DOWN” key simultaneously until OSD comes out as below.

The OSD of factory mode is same format as the user mode except the color of the bottom line. (User mode is blue; factory mode is red as shown below)

TOVIS	TOVIS P/N	MTG-1972XN	DATE	2002.03.11
		Color Monitor Service Manual	REV NO.	0
			PAGE	15/30

	BRIGHTNESS		50
	CONTRAST		Max
	H.POSITION		50
	H.SIZE		50
	V.POSITION		50
	V.SIZE		50
	PINCUSHION		50
	TRAPEZOID		50
	PARALLELOG		50
	PIN BALANCE		50
	COLOR		
	RECALL		
	LANGUAGE		
800X600 75Hz/46.8KHz			

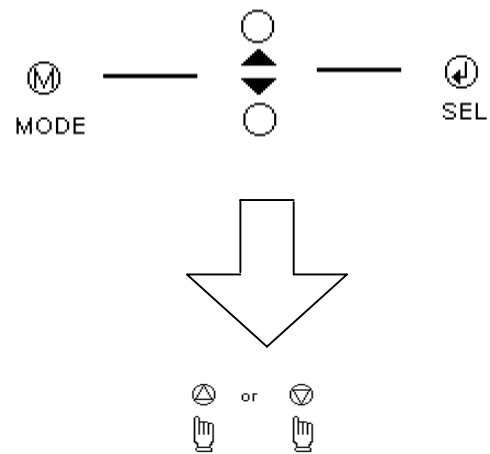

B. Exit and save.

- 1) After finishing the adjustment; search "RECALL" using the "UP/DOWN" key.
- 2) Press the "SEL" key until the OSD disappears then the adjusted value is saved. Exit from the factory mode.

C. Adjustment.

All adjustment methods are the same as the user's control mode except "COLOR".

TOVIS	TOVIS P/N	MTG-1972XN	DATE	2002.03.11
		Color Monitor Service Manual	REV NO.	0
			PAGE	16/30

D.COLOR ADJUSTMENT.

- 1) Before adjusting "COLOR", "CONTRAST" and "BRIGHTNESS" fix levels at maximum. (It's a TOVIS's reference condition.)
- 2) At the factory mode, search "COLOR" using "UP/DOWN" key.
- 3) Select "COLOR" by pressing "SEL" key then the color sub-menu comes up as in figure below left.
- 4) Search a color temperature that you want to adjust (gain or bias) using "UP/DOWN" key.
("GAIN" means high-beam area's adjustment and "BIAS" means low-beam area's adjustment.)
- 5) Select any item wanted by pressing "SEL" key then the OSD changes to under sub-menu as right below figure.
- 6) Adjust color temperature using "UP/DOWN" and "SEL" key.
("UP/DOWN" key: moves item position, "SEL" key : changes value.)
- 7) At the "GAIN" mode, "CO" means sub-contrast adjustment.
Sub-contrast can be adjusted using "UP/DOWN" key if necessary.
(To meet the white peak "ft" level.)
- 8) Press "MODE" key to finish the "GAIN" or "BIAS" adjustment.
- 9) If you want to adjust other "GAIN" or "BIAS",
Repeat from item 4) to 8).
- 10) Press "MODE" key to finish the "COLOR" adjustment.
- 11) If you want to finish factory adjustment, Select "RECALL"
as in item "B. Exit and save"

TOVIS	TOVIS P/N	MTG-1972XN	DATE	2002.03.11
		Color Monitor Service Manual	REV NO.	0
			PAGE	17/30

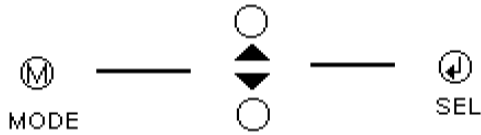

9300 GAIN	9300 BIAS
6500 GAIN	6500 BIAS

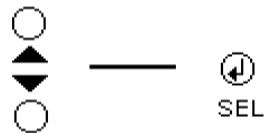

At
GAIN

RG	GG
BG	CO

OR

At
BIAS.

RB GB
BB

“SEL” and “UP/DOWN”

☀	BRIGHTNESS	██████████	50
☾	CONTRAST	██████████	Max
□	H.POSITION	██████████	50
▢	H.SIZE	██████████	50
▣	V.POSITION	██████████	50
▤	V.SIZE	██████████	50
▥	PINCUSHION	██████████	50
▦	TRAPEZOID	██████████	50
▧	PARALLELOG	██████████	50
▨	PIN BALANCE	██████████	50
😊	COLOR		
▶	RECALL		
🗨	LANGUAGE		
800X600 75Hz/46.8KHz			

TOVIS	TOVIS P/N	MTG-1972XN	DATE	2002.03.11
		Color Monitor Service Manual	REV NO.	0
			PAGE	18/30

7. Adjustment Specification

7-1. Adjustment Sequence.

It needs minimum of 15 minutes of warm up time before adjustment.

7-2. Adjustment Sequence.

FBT B+ Voltage → G2 Voltage → Hor. Center → Hor. Size → Hor. Position → Ver. Size → Ver. position → Side-pin → Trapezoid → Focus → White balance → Convergence

7-3. Adjustment Procedure.

How to enter the Factory Mode : Press Menu and Down key simultaneously.

7-3. 1. FBT B + voltage adjustment.

- 1) Input the crosshatch pattern with the 48KHz 1024*768 mode.
- 2) After connecting a digital voltage meter to the each pin of D316, anode and cathode adjust FBT B+ voltage to 114V ± 1.0V using VR301.

7-3. 2. G2 Voltage adjustment.

- 1) Input the cross-hatch pattern with 48KHz 1024*768 mode
- 2) After connecting a DC high voltage meter to the G2 of the CRT socket, adjust G2 voltage to 600V ± 10V by changing SCREEN VR of FBT.

7-3. 3 G/D Adjustment.

Refer to controls and adjustment.(Article 6)

7-3. 4 Focus adjustment.

- 1) Input the "H" character pattern with 48KHz 1024*768 .
- 2) Adjust the focus for the best balance at each point of A, B, C, D, E as shown below by rotating the focus VR of FBT.

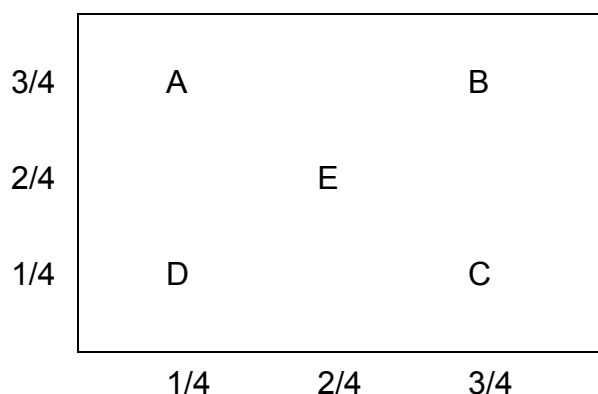

TOVIS	TOVIS P/N	MTG-1972XN	DATE	2002.03.11
		Color Monitor Service Manual	REV NO.	0
			PAGE	19/30

7-3.5. White balance Adjustment. (25% Window Box pattern)

Pre-adjustment

- 1) This should be carried out for at least 15 minutes.
- 2) Input the window pattern with 31KHz 640*480 mode.
- 3) Degauss the screen with Manual degaussing coil.

White Balance adjustment (Back Raster)

- 1) Remove the video signal
- 2) Adjust the sub-brightness of back raster to be **0.85FT±0.15FT** with SUB BRIGHTNESS volume VR501.
- 3) And, adjust the color temperature to be X=0.281 ±0.015 and Y=0.311 ±0.015 by R.G.B bias control function on OSD menu.
- 4) Adjust BRIGHTNESS to be **0.85FT ±0.15 FT.**

White Balance adjustment (Video)

- 1) Input the 25% window pattern with 31KHz 640*480 mode.
- 2) Adjust the color temperature to be X=0.281 ±0.015 and Y=0.311 ±0.015 by R.G.B gain on OSD menu.
- 3) Adjust CONTRAST to be **60FT ±5 FT.**

7-3. 6. Purity and Convergence Adjustment.

1) Purity Adjustment.

- ① Demagnetize the picture tube and cabinet using a degaussing coil.
- ② Turn the CONTRAST and BRIGHTNESS controls to maximum.
- ③ Adjust RED and BLUE bias controls to provide only a green raster
- ④ Loosen the clamp screw holding the yoke, and slide the yoke, backward to provide vertical green belt(zone) in the picture screen.
- ⑤ Remove the Rubber wedges.
- ⑥ Rotate and spread the tabs of the purity magnet see figure 1 around the neck of the picture tube until the green belt is in the center of the screen. At the same time, center the raster vertically.
- ⑦ Move the yoke slowly forward until a uniform green screen is obtained. Tighten the clamp screw of the yoke temporarily.

TOVIS	TOVIS P/N	MTG-1972XN	DATE	2002.03.11
		Color Monitor Service Manual	REV NO.	0
			PAGE	20/30

- ⑧ Check the purity of the red and blue raster by adjusting the bias controls.
- ⑨ Obtain a white raster, referring to "CRT GRAY SCALE ADJUSTMENT"
- ⑩ Proceed with convergence adjustment.

2) Convergence adjustment.

- ①. Receive crosshatch pattern with a color bar signal generator.
- ②. Adjust the BRIGHTNESS and CONTRAST Controls for well defined pattern.
- ③. Adjust two tabs of the 4-Pole Magnets to change the angle between them (See figure 1) and superimpose red and blue vertical lines in the center area of the picture screen.
- ④. Turn both tabs at the same time keeping their angles constant to superimpose red and blue horizontal lines at the center of the screen. (See figure 2.)
- ⑤. Adjust two tabs of 6-Pole Magnets to superimpose red/blue line with green one. Adjusting the angle affects the vertical lines and rotating both magnets affects the horizontal lines
- ⑥. Repeat adjustment 3,4,5 Keeping in mind red, green and blue movement, because 4-Pole Magnets and 6-Pole Magnets interact and make dot movement complex.

TOVIS	TOVIS P/N	MTG-1972XN	DATE	2002.03.11
		Color Monitor Service Manual	REV NO.	0
			PAGE	21/30

8. DESCRIPTION OF CIRCUIT OPERATION

8-1. Mode control

8-1.1. H-Sync is inputted to pin 30 of IC601, V-Sync to pin 29 of IC601 for each mode, and pin 27, 26 of IC601 output always-positive polarity sync.

8-1.2. The outputs from IC601 are as below (See Table 1)

No.	Frequency		Resolution	Range of Frequency		OUT PUT (MCU PIN)			
	Hf KHz	Vf Hz		Hf (kHz)	Vf (Hz)	CS3 38	CS2 39	CS1 40	SUS- 4
1	31	70	720x400	28~ 32.9	68~ 72	L	L	L	H
2	31	60	640x480	"	58~ 62	L	L	L	H
3	35	86	1024x768	33~ 35.9	84~ 88	H	L	L	H
4	38	75	640x480	36~ 40.9	73~ 77	H	H	L	H
5	38	60	800x600	36~ 40.9	58~ 62	H	H	L	H
6	47	75	800x600	41~ 51.9	73~ 77	H	L	H	H
7	48	72	800x600	"	70~ 74	H	L	H	H
8	48	60	1024x768	"	58~ 62	H	L	H	H
9	53	85	800x600	52~ 61.9	83~ 87	L	H	H	H
10	56	70	1024x768	"	68~ 72	L	H	H	H
11	60	75	1024x768	"	73~ 77	L	H	H	H
12	64	60	1280x1024	62~ 70	58~ 62	H	H	H	H
13	69	85	1024x768	62~ 70	83~ 87	H	H	H	H
14	-	-	-	$H \leq 10$	NORMAL	X	X	X	L
15	-	-	-	NORMAL	$V \leq 40$	X	X	X	L
16	-	-	-	$H \leq 10$	$V \leq 40$	X	X	X	L

TOVIS	TOVIS P/N	MTG-1972XN	DATE	2002.03.11
		Color Monitor Service Manual	REV NO.	0
			PAGE	22/30

8-2. Deflection Processor (IC301)

8-2.1. Horizontal section

1) Horizontal oscillation

R314 and C347 set horizontal free frequency to 48KHz.

Auto-sync processing can be done from 30KHz to 70KHz by mean of IC301 without any adjustment.

2) Phase shift

Horizontal phase shift is controlled by IC601 using I²C BUS control.

3) Horizontal driver output

The output pulse, which has the duty-cycle of 47%, is available at pin 26 of IC301.

This output is used for horizontal drive circuit.

4) B+ control driver output

The output pulse is available at pin 6 of IC301 and it is used for H-scan voltage control driver.

5) X-ray protection

When the fly-back voltage rises up to unacceptable level X-ray protection is activated X-ray input pin 13 of IC601 is above 4V.

This result is that the completed line drive stage stops working.

The reset of this protection is obtained by Main power off.

8-2.2. Vertical section

1) Vertical oscillation

The free running frequency of the vertical oscillator is determined by the capacitor C342 at pin VCAP (pin22) of IC301.

2) Vertical amplitude

Vertical amplitude is controlled by IC601 using I²C.

3) Vertical position

Vertical position is controlled by IC601 using I²C.

4) East-west parabola

A parabola waveform is available on pin 24 of IC301 for driving the pincushion correction stage. Amplitude of parabola waveform is controlled by IC601 using I²C.

TOVIS	TOVIS P/N	MTG-1972XN	DATE	2002.03.11
		Color Monitor Service Manual	REV NO.	0
			PAGE	23/30

8-2.3. B+ Regulator

B+ PWM regulator output is available on pin 28 of IC301 for driving the B+ control stage. This PWM output is adjusted through VR301.

8-3. Vertical Deflection (IC201)

IC201 (KA2142) is used for direct driving of vertical deflection yoke.

8-4. Horizontal scan voltage control stage

The step-up converter is used in this stage.

The output pulse at pin 28 of the IC301 is synchronized on horizontal frequency. And this pulse is operated via buffer stage Q311/Q312.

This output is rectified through D315/L304.

In this way, the supply voltage to the fly-back transformer can be proportional to the horizontal line frequency.

8-5. Horizontal deflection output stage

8-5.1. Line driver stage

As a driver device, small MOSFET Q307 (IRF630) is used.

The driver transformer T302 is equipped with a snubber circuit (R327/C309) at the primary side to damp excessive ringing.

8-5.2. Horizontal power output stage

The horizontal power output stage is a conventional one with a diode modulator.

As a deflection transistor, the Q308 (2SC5682) is used.

To compensate the horizontal linearity, T301 is connected in a series with the horizontal DY. It is controlled by DC collector voltage of Q304, which the base voltage of Q304 is integrated from output at pin 22 of IC601.

8-5.3. S-correction capacitor switches

Q316 is off when horizontal frequency is 35KHz.

Q316, Q317 is off when horizontal frequency is 37KHz.

Q316, Q318 is off when horizontal frequency is 43KHz-52KHz.

Q317, Q318 is off when horizontal frequency is 53KHz~ 61KHz.

Q316, Q317, Q318 is off when horizontal frequency is 62KHz~ 70KHz.

Q316, Q318 is off when input is override condition.

TOVIS	TOVIS P/N	MTG-1972XN	DATE	2002.03.11
		Color Monitor Service Manual	REV NO.	0
			PAGE	24/30

8-6. FBT (Fly-back Transformer)

The high voltage for CRT anode focus, G2 voltage for CRT and - 12V for vertical deflection are generated by the FBT.

Also, -130V for G1 voltage, -12V for the vertical supply voltage are extracted from the FBT.

8-7 ABL (Automatic Beam Limiting)

The voltage of the FBT pin10 is affected by the anode current of the FBT.

When the voltage at pin 10 is decreased, the anode current is increased accordingly. When the anode current is increased, contrast is set at the certain limited level (28FL in white pattern) that is set by inner voltage of IC401.

8-8. Video amplification section.

8-8.1. Video pre-amplifier (IC401)

Input video signals are amplified by means of IC401, and the amplified signals drive the video output stage (IC402).

Video gain is adjusted by DC voltage at pin 12 for ABL control.

8-8.2. Video output stage (IC402)

The video output signal from IC401 is amplified again by IC402, and IC402 apply video signal to each cathode of CRT.

Q405, Q406 and Q407, which is operated by I2C BUS control through u-com, adjust cutoff voltages.

8-8.3. OSD (On Screen Display: IC403)

The OSD signal is applied from IC403 to IC402.

It is controlled by I²C BUS control line.

TOVIS	TOVIS P/N	MTG-1972XN	DATE	2002.03.11
		Color Monitor Service Manual	REV NO.	0
			PAGE	25/30

9. TROUBLE SHOOTING

9-1. NO POWER

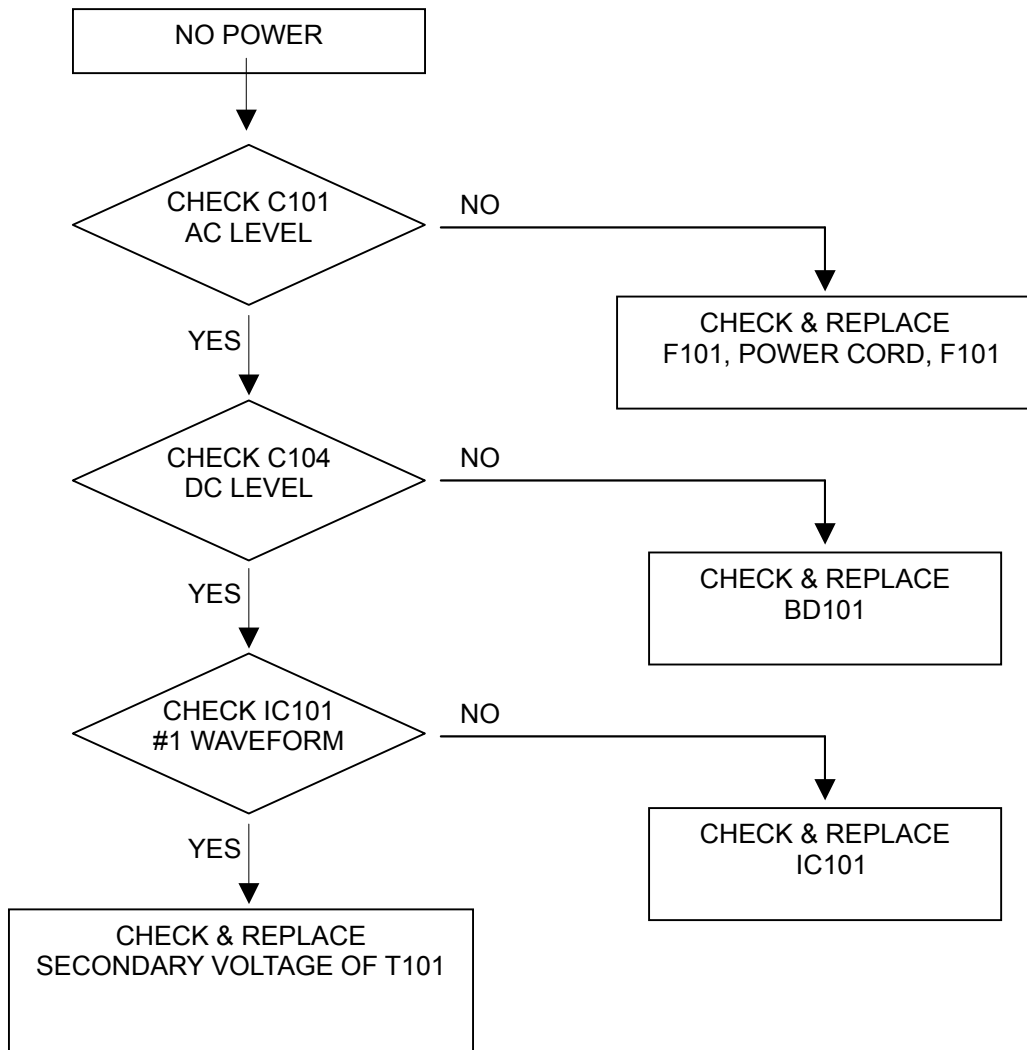

TOVIS	TOVIS P/N	MTG-1972XN	DATE	2002.03.11
		Color Monitor Service Manual	REV NO.	0
			PAGE	26/30

9-2. NO VIDEO

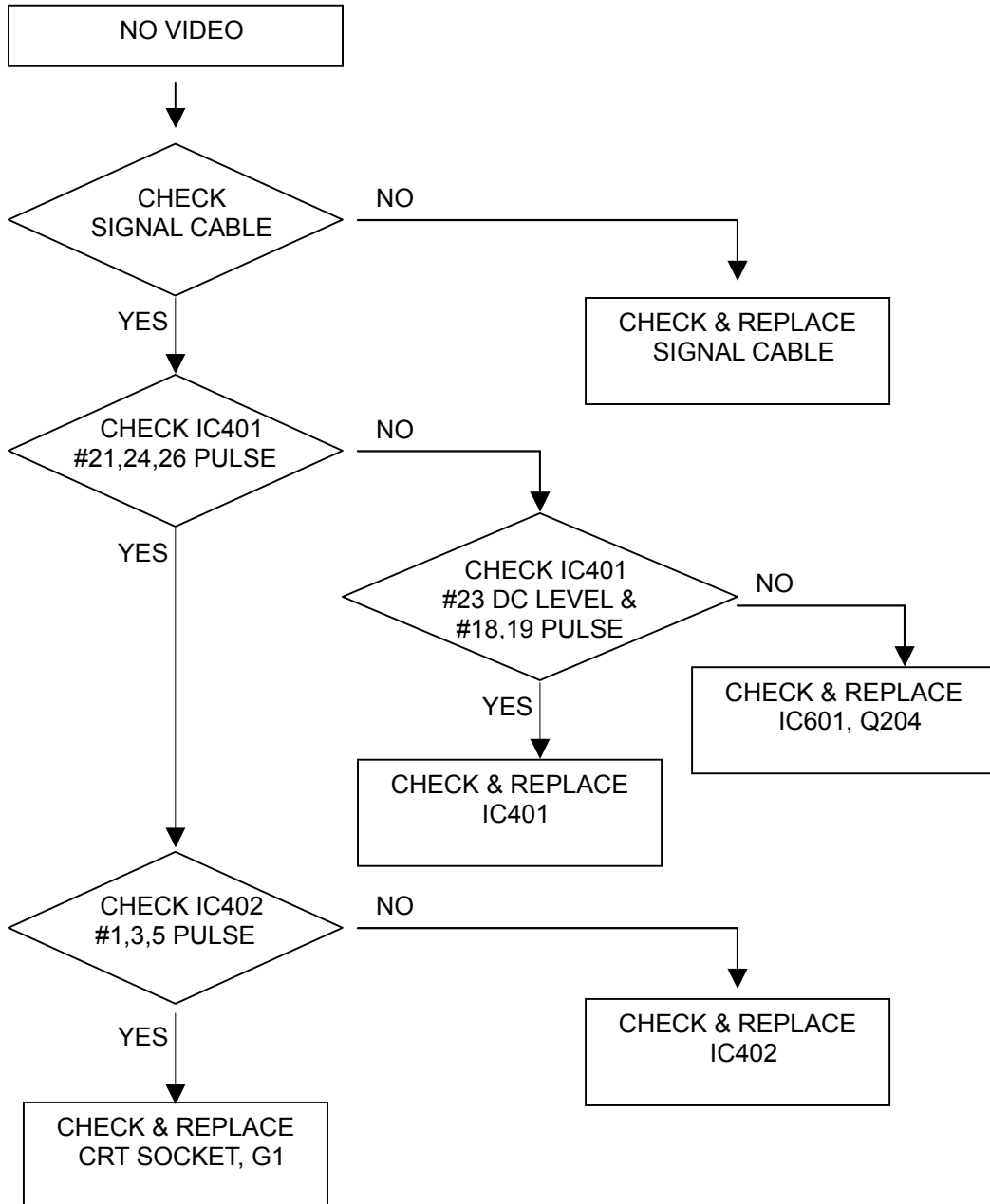

TOVIS	TOVIS P/N	MTG-1972XN	DATE	2002.03.11
		Color Monitor Service Manual	REV NO.	0
			PAGE	27/30

9-3. NO RASTER

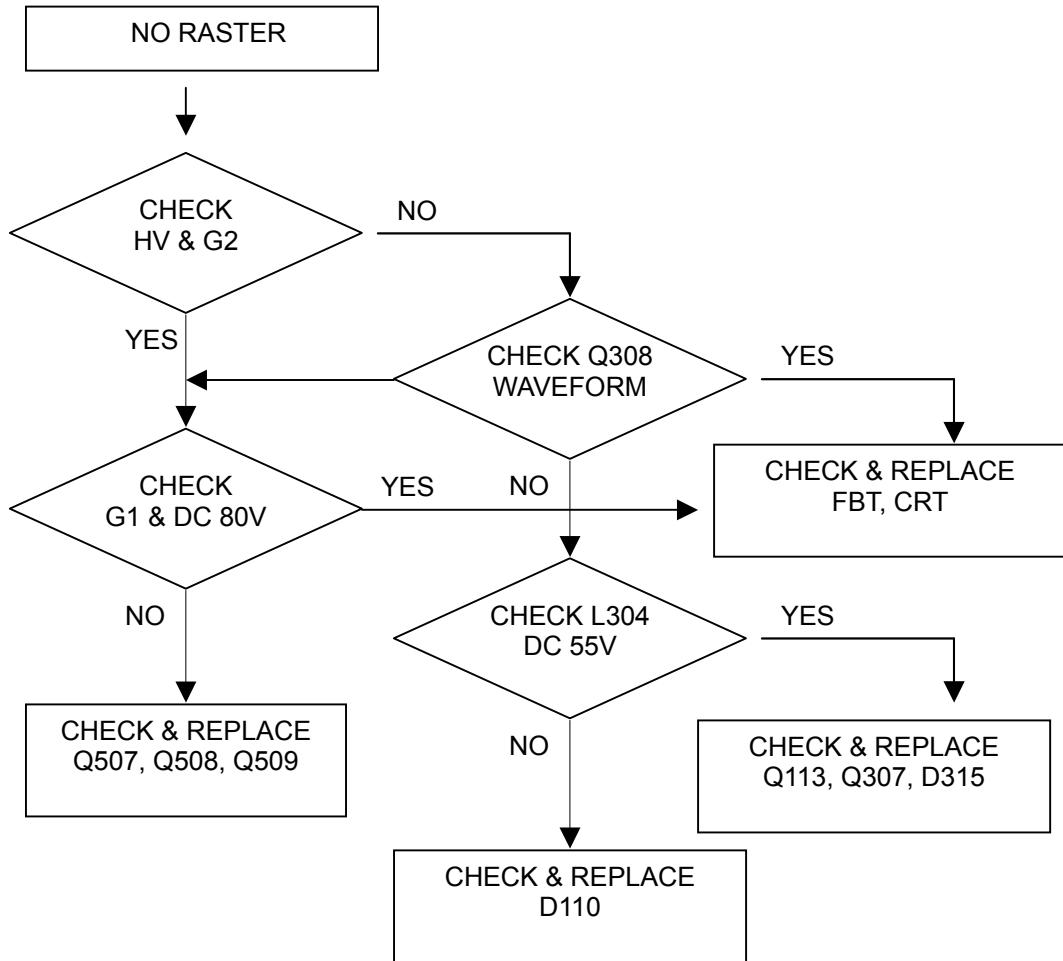

TOVIS	TOVIS P/N	MTG-1972XN	DATE	2002.03.11
		Color Monitor Service Manual	REV NO.	0
			PAGE	28/30

9-4. TROUBLE IN HORIZONTAL SIZE

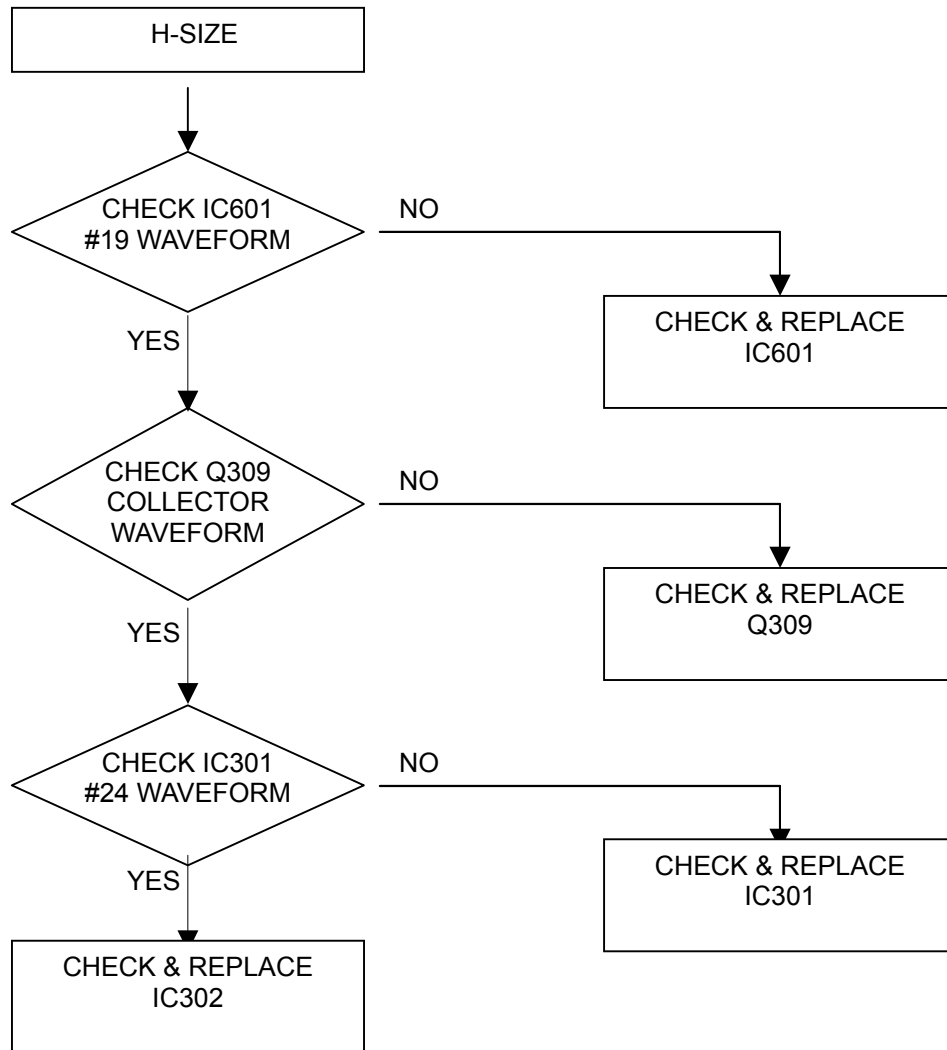

TOVIS	TOVIS P/N	MTG-1972XN	DATE	2002.03.11
		Color Monitor Service Manual	REV NO.	0
			PAGE	29/30

9-5. TROUBLE IN CONTRAST

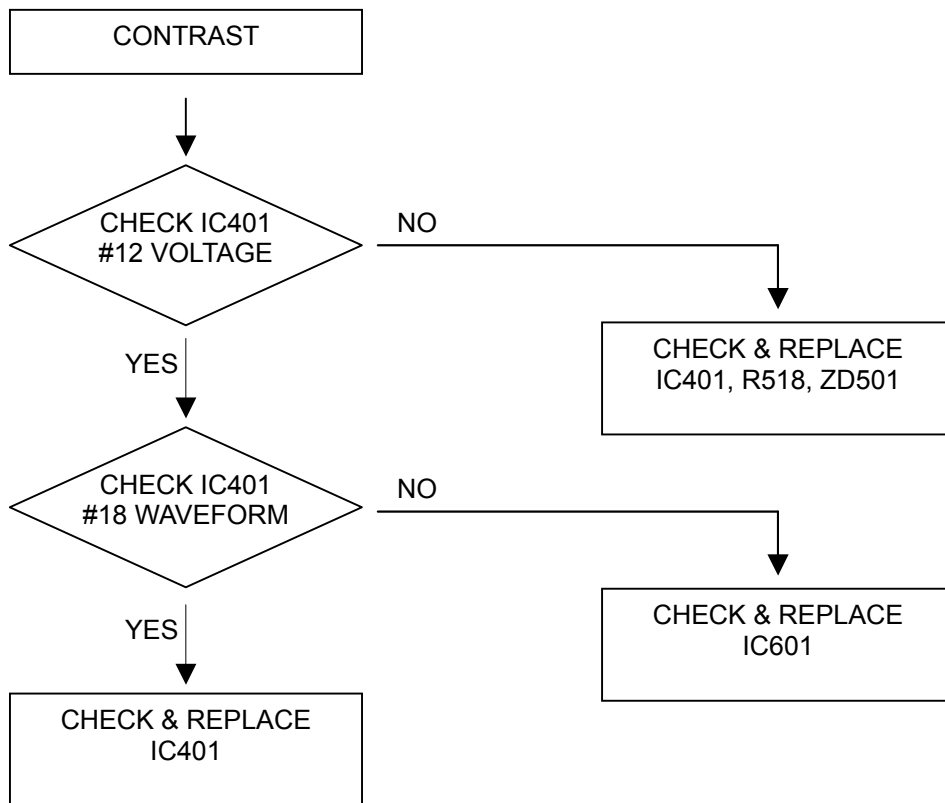

TOVIS	TOVIS P/N	MTG-1972XN	DATE	2002.03.11
		Color Monitor Service Manual	REV NO.	0
			PAGE	30/30

9-6. TROUBLE IN BRIGHTNESS

