



# ***PERIPHERALS***

## **MODULE 8**

**MK8-SVMOD-0002**  
**PERIPHERALS**

©2002 BALLY GAMING AND SYSTEMS ALL RIGHTS RESERVED

Bally Gaming and Systems  
6601 South Bermuda Road, Las Vegas, NV 89119

For Customer Service and information:  
+1-702-896-7772 Outside the U.S.  
1-877-GO-BALLY (877) 46-22559 in the U.S. and Canada  
896-7772 in Las Vegas  
FAX: +1-702-896-7710  
or visit our website at <http://www.ballygaming.com>

## Module 8

# Peripherals Table of Contents

---

<b>Coin Acceptors .....</b>	<b>5</b>
Coin Mechanisms, Inc. CC-16 .....	5
Coin Mechanisms, Inc. CC-62 .....	6
Coin Mechanisms, Inc. Micro Comparitor MC .....	7
Money Controls Condor CN103 .....	8
National Rejectors, Inc. G-13, 0000 .....	9
IDX, X-10 and X-70 X-Mark Xeptors .....	9
<b>Bill Acceptors .....</b>	<b>13</b>
JCM® WBA-SS .....	13
JCM® SENTRY™ - Intelligent Bezel .....	16
JCM® DBV-200 .....	18
Mars ZT Series 1000 .....	20
Money Controls Ardac WACS .....	24
<b>Hoppers .....</b>	<b>25</b>
Bally Gaming and Systems XS-1200 .....	26
Asahi Seiko DH-750 .....	29
<b>Ticket Printers .....</b>	<b>36</b>
Ithaca Series 70 Impact Ticket Printer .....	36
Ithaca Series 700 Thermal Ticket Printer .....	40
Seiko PSA-66 Thermal Ticket Printer .....	42
<b>Accounting System Interface .....</b>	<b>44</b>
<b>Accounting System Settings .....</b>	<b>47</b>



## Coin Acceptors



Coin Mechanisms, Inc. • 400 Regency Drive,  
Glendale Heights, Illinois 60139-5128 • Toll  
Free: (800) 323-6498 Phone: (630) 924-7070  
Fax: (630) 924-7088 • www.coinmech.com

### CC-16

Power Requirements:  
fixed VDC models, 11.5  
to 12.5 VDC

Feed Rate: 7 coins per  
second (models CC-16,  
CC-62, MC-16):

Designed for coin  
diameters of .700"  
(17.8mm) to 1.575 (40mm). Wide Body model  
recommended for coin diameters up to 1.95"  
(49.5mm).



CC-16

Operating temperature recommended: 0° to 60°C.

Installing the Sample Coin (models CC-16, CC62, MC-16): Looking at the front of the comparator, slide (without lifting) the sensor coil assembly to the right. Replace the sample coin (or chip) with the desired coin (or chip) and then carefully release. In most cases, the coin (or chip) will automatically seat itself. When properly seated, the coin (or chip) will rest parallel between the sensor coil assembly and between the ribs on the rail insert.

Replacing an Existing Mechanical Acceptor (models CC-16, CC-62, MC-16):

1. Remove the acceptor.
2. Disconnect the coin return linkage.
3. Remove the lockout coil (if used).
4. In some cases, the comparator mounting studs may need to be relocated to meet manufacturer's mounting specifications.
5. Mount comparator into equipment, ensuring that coin entry and coin exit are aligned.

Wiring Instructions: The CC-16 printed circuit board requires a 6-pin JST terminated interface. The connector diagram following denotes the typical voltage line pinouts to the printed circuit board:

1. Inhibit input - 12VDC models only  
All other models - Triac load
2. Sense output
3. 48 Volt
4. 24 Volt
5. 12 Volt
6. Ground

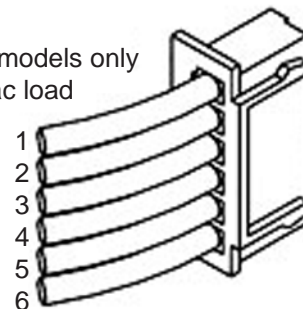

Potentiometer Adjustment (models CC-16, CC-62):

Each comparator is adjusted to give excellent discrimination against slugs. However, some high quality slugs may need a finer adjustment.

1. Adjust potentiometer clockwise (CW) until high quality slug is rejected.
2. Drop good coins to ensure accurate acceptance.
3. Repeat steps 1 and 3 if necessary. For further potentiometer adjustment procedures, call or fax Coin Mechanism, Inc.'s service department and request document #09300072.

Before Turning Power On (models CC-16, CC-62, MC-16):

1. Make sure that all connections are properly insulated.
2. Tuck wire to prevent interference with coin travel or coil armature movement.
3. Check the power cord for firm connection to the PC board.
4. Make sure the comparator is mounted securely in the equipment.
5. Check the entry chute alignment by inserting the proper coin. The coin should fall freely, without stopping, through the comparator and reject out of the equipment.

After Turning Power On (models CC-16, CC-62, MC-16):

1. The LED will illuminate when voltage is applied.
2. Drop good coins. They should be recognized by the comparator and accepted.
3. Repeat step 2 several times to ensure the unit is functioning properly.

## Coin Acceptors (cont.)

### CC-62

Power Requirements: Voltage Range, 11.5 to 12.5 VDC.

Designed for coin diameters of .700" (17.8mm) to 1.575 (40mm). Wide Body model recommended for coin diameters up to 1.95" (49.5mm).

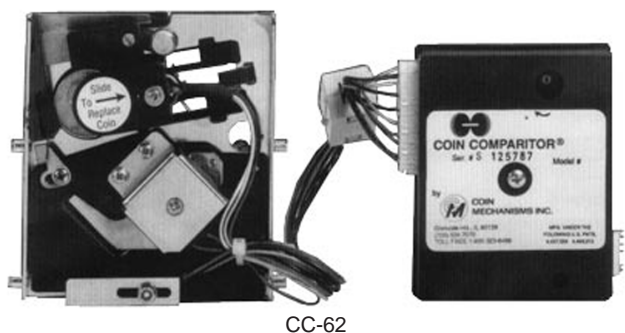

CC-62

Wiring Instructions: The CC-62 printed circuit board requires a 7-pin AMP right angle locking connector interface.

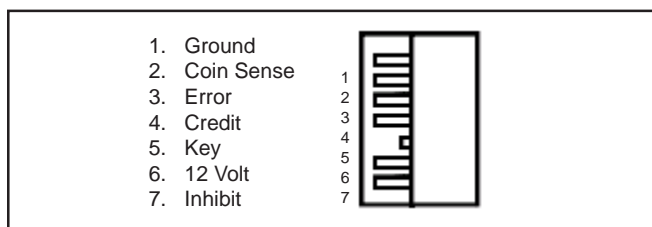

Operating Voltage: The neutral or ground (GND) of the voltage source should be wired directly to pin #1 of the printed circuit board.

The hot or positive 12-Volt DC of the voltage source is wired directly to pin #6 of the printed circuit board. These connections now provide the operating voltage to the comparator.

Two Separate Outputs: When the sensing coils sense a good coin, a pulse is sent out to the host machine. Following this, the accept gate opens, and as the coin passes the LED optics a credit pulse is also sent out to the host machine. Together these two pulses provide optimum security against cheating. The host machine can be configured to recognize a valid coin only when both outputs have been detected.

The LED optics have been positioned such that coins falling edge-to-edge are guaranteed to be accepted without stealing.

Inhibit Feature: The CC-62 has an inhibit feature built-in to its electronics. The unique feature about the CC-62

inhibit is its ability to electronically inhibit the validator without removing power from it, thereby eliminating any power-up time delay. The inhibit condition is accomplished by disabling only the accept coil.

The inhibit line is wired to pin #7 of the printed circuit board.

Coin Sense Output Feature: The CC-62 sends a coin sense output pulse when the sensing coils detect a good coin. This pulse is sent on pin #2 of the printed circuit board.

LED Credit Output Feature: The CC-62 sends a credit pulse from the optics when a good coin has passed. This pulse is sent on pin #4 of the printed circuit board.

Tilt/Error Signal Feature: Another security feature of the CC-62 is its ability to protect against stringing. The optics are positioned in an A-Over-B pattern. This means that a coin must first block then uncover both the top and the bottom optic before a credit pulse is issued. If the bottom optic is blocked before the top, the CC-62 issues a tilt pulse on the tilt/error output line. The error signal, which is on the same output line, is used in the event of a failed or blocked optic. In the event an optic is blocked for a period of more than 1.5 seconds, the tilt/error output line goes low and will remain low for as long as the failed or blocked optic remains.

The built-in tilt/error detection line can be utilized by wiring to pin #3.

Denomination Adjustment: As with any comparator product it is essential that the proper dampener lever and weight assembly are used for the size coin being validated. For the CC-62 there is an additional adjustment step that is critical to proper operation. This adjustment is to the adjustable guide rail. The adjustable guide rail ensures that a good coin, once accepted, adequately passes the optics as it exits the validator body.

To perform this adjustment, loosen the rail screw on the adjustable guide fail, as well as the elastic nut on the rail support bracket. Position the bottom of rail so that you have the full diameter of the coin's width, plus  $1/32''$  over. This guarantees proper optic blockage for the size coin being validated. After adjusting rail, make sure to fully tighten the rail screw to hold the adjustment made. Proceed by aligning the tip of the rail support bracket to the end of the rail, then tighten the elastic nut in place.



**NOTE:** An adjustment gage tool may be purchased from Coin Mechanisms directly by calling the Parts Sales department at (630) 924-7070 and requesting part number #06660003.

## Coin Acceptors (cont.)

### Micro Comparitor MC (Replacement for CC-16 and CC-62)

Designed for coin diameters of .700" (17.8mm) to 1.47" (37.34mm). Wide Body model recommended for coin diameters up to 1.950" (49.5mm).



MC-16

**Wiring Instructions:** The printed circuit board is available with one of two possible connectors. A 7-pin Molex header is used when emulating a model CC-62; a 6-pin JST header is used to emulate both the CC-16 and CC-40.

**Operating Voltage:** There are two different models offered, a 12 Volt DC only model, and a multi-voltage model which allows for operations from 20 to 40 Volts DC, or 20 to 30 Volts AC.

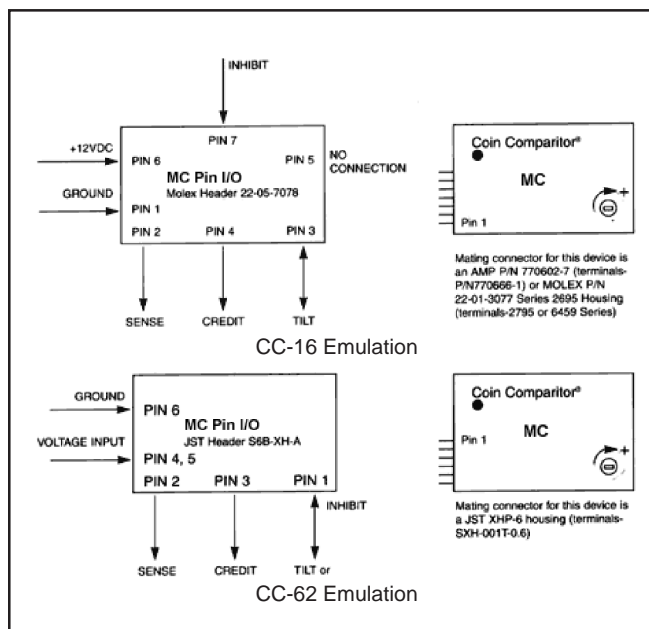

**Inhibit Input Feature:** The INHIBIT feature is an input which allows you to disable the device without removing power from it. The INHIBIT pin can be configured to accept either a LOW or HIGH level signal to inhibit the device.

**Tilt Output:** The TILT signal is an output which alerts the machine of a malfunction or tampering of the device. There are different MC conditions which will generate a TILT

signal, and the lengths of the pulses can be changed to accommodate different machine requirements. Additionally, a NULL signal is an internal signal generated when a valid coin passes the sensor coils. If this NULL signal is too long (> 250ms as sometimes occurs when stringing) the TILT line will output a signal. If any of the optics are blocked for 1.5 seconds or longer the TILT line will be active until the condition is corrected. If a coin is detected moving past the optics in a reverse direction (stringing) a TILT pulse occurs. If a coin passes the optics without a matching sense pulse a TILT occurs (note 1). The mechanism will not accept coins when the TILT line is active.

**Credit Signal:** The CREDIT signal is an output which occurs for every valid coin that is accepted properly through the mechanism. A CREDIT is generated by the internal microcontroller only when a valid sense pulse is matched with a corresponding optic pulse. This close control between the sense signal and the optic signal allows more accurate monitoring of coins through the mechanism. The CREDIT signals are buffered and therefore are fixed in length and duty cycle regardless of coin feed rate.

**Sense Signal:** The SENSE signal is an output which simply indicates that a valid coin has passed the sensor coils. It is available for those applications requiring a pre-count or verification that valid coins have entered the device.

**Bi-Color Status Indicator:** The MC-16/40/62 incorporates a bicolor (green / red) LED on its front cover to easily indicate the operating status of the mechanism visually. The LED will be green when power is applied to the device and it is enabled (INHIBIT not active) to accept coins. The LED will be red if the INHIBIT line is active (disable coin acceptance) or if there is no resident coin in place. The LED will also change to red when the TILT line is active (error condition). When the LED is red the device will not accept coins.



## Coin Acceptors (cont.)

**Money Controls**  Money Controls • New Coin  
Street, Royton Oldham OL2  
6JZ United Kingdom • Phone:  
+44 161-6780111 Fax: +44 161-6267674 •  
www.moneycontrols.com

### Condor CN103

Power Requirements: Volt-  
age, 12 VDC to 32 VDC

Operating temperature: 0°  
to 60° C.

Maintainable life of 20 mil-  
lion coins.

Coinage: Accepts coins  
within the diameter range  
of .59-1.75" (15-44.5 mm)  
and the thickness range of .059-.148" (1.5-3.75 mm).

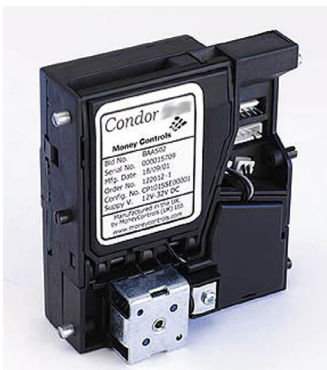

CN103

#### Wiring Instructions:

- |             |   |
|-------------|---|
| Connector 1 | Pin 1 Inhibit all<br>Pin 2 VACS +6V<br>Pin 3 +12 to 32 VDC<br>Pin 4 +12 to 32 VDC<br>Pin 5 +12 to 32 VDC<br>Pin 6 +0V |
| Connector 2 | Pin 1 Accept (b) NPN generation<br>Pin 2 VACS NPN<br>Pin 3 Alarm<br>Pin 4 Error                                       |
| Connector 3 | Serial Port   |
| Connector 4 | LCD display   |





Alarm: Open collector NPN is activated for 2 seconds with inhibit all. This condition occurs when coins travel in reverse, too slowly or block the opto beams. A continuous yellow LED will result for the duration of the alarm. During this time a pulse will appear on the error pin.

Error: When a critical failure is detected at power up a 500ms pulse will be given on the error line and will repeat every 2 seconds. The LED will flash red and all coins will be inhibited.

Teach and Run™ Programming: Follow these steps to program:



#### LED Status

- Select window 1 
- Press button 
- Start feeding coins/tokens until 
- Press button - normal operation 
- Select security (see 5.0)

Security: The acceptance window can be adjusted to increase fraud rejection or increase coin acceptance.



- Clockwise (Increase fraud rejection)
- Anticlockwise (Increase true coin acceptance)
- 0 (Normal)



## Coin Acceptors (cont.)



National Rejectors, Inc. GmbH • Postfach 1461 • Buxtehude 21604, Germany • Phone: +49 41 617 290 Fax: +49 41 617 29115 • www.nationalrejectors.com

### G-13, 0000

Power Requirements: 12 VDC +3/-1 Volts tolerances

Operating temperature 0° to 55° C.

Acceptance: Up to six different coins.

Diameter: between .59" and 1.22" (15 and 31mm).

Thickness of coins: between .059" and .1" (1.5 and 2.6 mm)

Dimensions: Height 4" (102 mm) Width 3.5" (89 mm) Depth 2" (52 mm)

Temperature range: 0° C up to +55° C

Coin inhibit: A common blocking line for all coins is available. Single coin inhibit may be achieved by DIP switches on the G-13.

Measuring principle: Three inductive sensors are arranged to detect material, thickness, diameter and embossing of coins as they pass. The passing coin activates the sensors, providing different voltage measuring values. These voltages are digitized and processed within the microprocessor.

Programming of acceptor: A standard computer (IBM PC or compatible) allows programming of the acceptor for any coin acceptance. Programming means just the insertion of a coin which should be accepted. Please refer to the document "Use of program PROEMP."

#### Wiring

1. Ground
2. +12 VDC
- 3, 4, 7, 8, 9, 10. Coin Signals\*
5. N.C.
6. Coin Inhibit

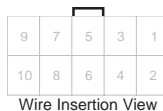

\*Coin Signals: <.07 volts active low / 150 mA Open collector NPN. I max = 150 mA, Umax = 35 volts. Time of pulses: 100 msec +/- 10%.

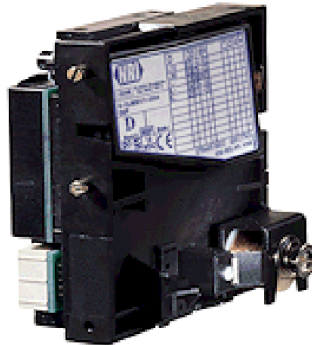

G-13, 0000



IDX, Incorporated • 400 W. Cedar St. • El Dorado AR 71730 • Ph: (800) 643-1109 FAX: 870-862-3472 • http://www.idxinc.com

### X-10 and X-70 X-Mark Xeptors

The X-10 and X-70 X-Mark Xeptors are multi-coin acceptors which can be field programmed to distinguish and accept any of up to six coins or tokens. Multi-coin acceptance offers the possibilities of mixing promotional tokens with standard tokens, accepting older tokens with new tokens in the process of change-over, or replacing expensive (4x) hopper fill real currency with economical tokens. Precision diameter measurement totally eliminates shaved coin acceptance problems. Its built-in multi-color indicator LED provides operational status and field diagnostic information. Its novel Personality Plug modules ensure plug compatibility in field retrofit applications.



X-10 X-Mark Xeptor

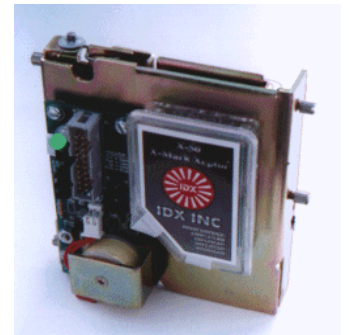

X-70 X-Mark Xeptor

#### Features:

- Distinguishes and accepts any of up to six different coins or tokens.
- Reads multiple X-Mark codes and optionally detects the presence of SmartMark.
- Diameter ranges: X-10: 0.650" to 1.490" (16mm to 38mm), straight drop configuration, X-70: 1.330" to 1.950" (34mm to 49mm) reverse drop configuration
- Actually measures coin diameter to +/- .005" typ (X-10), +/- .007" typ (X-70).
- Measures metal alloy 3 ways.
- Accepts up to 16 coins per second (X-10), 10 coins per second (X-70).
- Slide on access covers shed spilled liquids.
- Built-in coin release and opening coin chute.

## Coin Acceptors (cont.)

- New coin types can be field programmed without extra equipment.
- Multi-color indicator LED for operational status and field diagnostics.
- Universal electrical interface compatibility with existing legacy machines and new machines via Personality Plug modules.

### LED Status Indicator

- No light indicates no power. Plug it in, check your wires, check your power supply. Verify your Personality Plug.
- Solid green means normal operation for either switch position 0 (Run) or switch positions 7 to F (Field Test).
- Green with short red flash means the unit is normally operating and is secured from coin programming without using the X-Key. This is available starting with V3.0r firmware.
- Solid red is normal in switch positions 1-6 for coin programming. A red flash during coin acceptance indicates credit has issued.
- Alternating red-green means that the unit has detected some sort of malfunction. See Field Test to diagnose.
- Blinking yellow means Inhibit. It is inhibited from acceptance in switch position 0, inhibited from coin programming in switch positions 1-6, and Credit Optics not available in switch position 8.

### Personality Plugs

Personality plugs are small connector conversion modules about as big as the last segment of your little finger. They are used to convert the 8-pin header in the Xeptor to any of many available connector styles and pin assignments common in the industry. For example, there is one personality plug type for each of the older Coin Mechanisms CC-series acceptors and the NRI multi-wire output acceptors. Additionally, many have been designed to meet the needs of specific OEMs, including such things as simulation of OEM credit optics module signals. Other

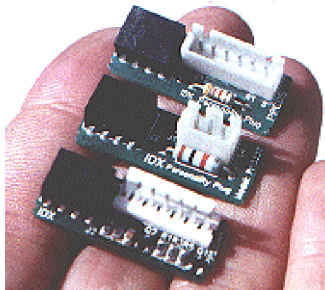

special interface requirements are easily satisfied with new Personality Plugs designed specifically for the job. With the correct personality plug installed in an Xeptor, retrofit installation requires no machine connector rewiring. The tables below can help in deciding which personality plug to use. Refer to the Electrical Specifications table following for each pin definition.

### Personality Plugs Table

Personality Plug Model	PP16	PP16IC	PPUNI	PPNRI-6	PPNRI-3
Compatibility Connector	CC-16 JST-6	CC-16 12V JST-6	Universal JST-6	NRI 10pin IDC	NRI 10pin IDC
Pin 1	1K to Gnd.	Inhibit	Inhibit	Ground	Ground
Pin 2	Sense	Sense	/Coin Optics	12VDC	12VDC
Pin 3	48 VDC/AC	----	----	/Output5	----
Pin 4	24 VDC/AC	24 VDC/AC	24 VDC/AC	/Output6	----
Pin 5	12 VDC	12 VDC	----	Coin Return	----
Pin 6	Ground	Ground	Ground	Inhibit	Inhibit
Pin 7				/Output1	/Output1
Pin 8				/Output2	/Output2
Pin 9				/Output3	/Output3
Pin 10				/Output4	----

### Electrical Specifications

SIGNAL	ELECTRICAL CHARACTERISTICS (Note: Pulse widths programmable via "P" command on serial port)
<b>INHIBIT</b>	Inhibit = float or >3.5VDC, Enable = < 1.0VDC
<b>SENSE</b>	Active high 32ms pulse, PNP 12V pull-up 10mA max, 3.3K pull-down.
<b>/SENSE</b>	Active low 32ms pulse, NPN sinking 10mA max, 47K 5V pull-up.
<b>/CREDIT</b>	Active low 32ms pulse, NPN sinking 10mA max, 47K 5V pull-up.
<b>/TILT</b>	Active low >32ms pulse, NPN sinking 10mA max, 47K 5V pull-up.
<b>/OUTPUT-n</b>	Active low >32ms pulse, NPN sinking 10mA max, 47K 5V pull-up.
<b>RELAY</b>	Relay contact terminal. 40V 0.2A peak rating..
<b>/Coin Optics</b>	Wire-OR optics output enable, 100ms low pulse, 100K 12V pull-up.
<b>48VDC/VAC</b>	Power input 38 to 55VDC, 38 to 55VAC, 35mA max @idle.
<b>24VDC/VAC</b>	Power input 14 to 32VDC, 16 to 32VAC, 35mA max @idle.
<b>12VDC</b>	Power input 11.5 to 16VDC, 25mA max @idle, 240mA accept gate.
<b>1K to Ground</b>	1K 1W resistor to circuit ground. (for triac holding current)
<b>Ground</b>	Circuit common.

### Field Tests and Diagnostics

The normal operation mode of the Xeptor is with the rotary switch position #0 where the LED is green. If the LED is flashing yellow, it means that the Xeptor is inhibited. This can be caused by an external control line such as from a door switch or otherwise as controlled by the machine that it connects to. It may also (although less likely) be caused by improper setting of the Inhibit bit in the SysConfig control byte. If the LED is alternating red-green, it indicates a malfunction has been detected. Some malfunctions can be corrected in the field.

**Gate Relay Test (rotary switch #0):** Press the test button to activate the gate relay. If it does not activate, it may be physically obstructed or its wire unplugged. This would be one cause for rejection of all coins.

# Peripherals

## Coin Acceptors (cont.)

**Inductive Metal Sensor Tests (rotary switch #E, #F):** Turn the rotary switch to positions #E and #F to test the inductive sensor. Normal LED color is green. A red color most often indicates either there is metal in front of the inductive sensors or that the flat cable going to the small sensor housing has been unplugged.

**Diameter Optics Sensor Tests (rotary switch #B, #C, #D):** Turn the rotary switch to positions #B, #C, and #D to test each of the three diameter through-beam optical sensors. Normal LED color is green. A red or orange color most likely indicated either there is an object or dirt blocking one of these three sensors and cleaning of the coin chute is required, or that the flat cable going to the small sensor housing has been unplugged.

**X-Mark Code Optics Sensor Calibration (rotary switch #9, #A):** Fold a piece of white paper twice (to 4 thicknesses) and insert it into the center of the coin chute. Turn the rotary switch to position #9 (rear side optics) and press the test button. The unit will use information gathered to calibrate the sensitivity of its reflective sensors for reading the X-Mark optical code on tokens. The LED should be an orange color after calibration. Repeat for switch position #A (front side optics). When you remove the paper, the LED should be green in both of the switch positions.

**Credit Sensor Test (rotary switch #8):** The credit optics (if installed) are located just above and below the gate relay rake. If they are not installed the LED will flash amber to indicate that the credit optics were not detected at power-up. If they are installed, the LED is normally green for proper function, and will become orange to red as they become blocked by dirt or other obstructions.

**Memory Test (rotary switch #7):** Turn the rotary switch to positions #7 to test the validity of memory. Normal LED color is green. A red color indicates that memory is corrupted. It may be possible to correct this by relearning the coins. If not, the memory chip is defective.

Auto Reporting

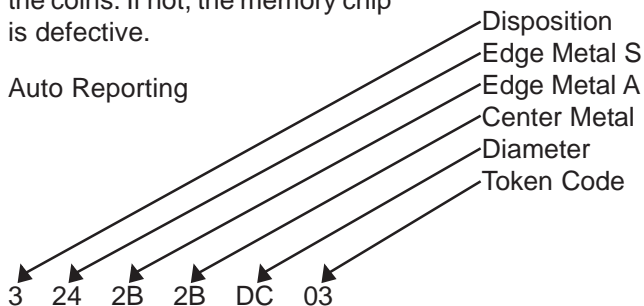

Auto report from a coin matching coin memory #3. The coin has the same edge and center metal, a diameter of 1.464" and an X-Mark code of 03.

The Xeptors will not "speak unless spoken to" except when a coin has been deposited. The Xeptor will automatically report the disposition and sensor readings taken from each coin when the analysis is complete and the SENSE pulse has been issued. If internal credit optics are installed, a subsequent report on slow or reverse coins may additionally occur. The auto report message consists of 6 data bytes in ASCII Hex format.

### Report Command

The "R" REPORT command produces a list of all the critical operational parameters of the Xeptor (see example following). In the first line, the software version is identified and the ID# of the unit is reported. The next eight lines report the detail contents of each of the six coin memories. The bits of the options byte are defined in the following table:

Example Configuration Report and Coin Auto Report Messages.	
Xeptor 30 (d) ID#:	1F5E -Firmware version and ID#
Coin Memory:	01 02 03 04 05 06
Coin Pulses:	0D 01 00 01 00 00
Token Code:	00 00 00 03 00 00
E-Metal S:	26 24 00 24 00 00
E-Metal A:	2E 2C 00 2C 00 00
C-Metal A:	2E 2C 00 2C 00 00
Diameter:	D9 DA 00 DC 00 00
Options:	01 01 00 81 00 00
Thresholds:	05 07 03 06 03 05 08 00 00
Tank Calib:	47 Tank Now: 47 51
Sys Config:	08 Tilt Time 1/3 sec: 09
Credit ms:	20 Divert Dly/Pls ms: 10 50
2 23 2D 2C D9 00	
2 25 2C 2C DC 00	
2 24 2C 2D DA 00	
4 24 2D 2D DB 03	- Distinguished by X-Mark from #2
D 35 3E 3E 1E 00	- Failed on diameter
2 23 2D 2C D9 00	
2 25 2C 2C DC 00	
M 2A 30 30 DA 00	- Failed on edge metal
4 25 2C 2C DC 03	
4 24 2C 2D DA 03	
4 24 2D 2D DB 03	
U 26 2D 2E D6 00	- Unwanted close slug for #2
U 27 2E 2D DA 00	- Unwanted close slug for #2
I 00 00 00 00 00	
I 00 00 00 00 00	- Xeptor inhibited
I 00 00 00 00 00	
2 23 2D 2C D9 00	
2 25 2C 2C DC 00	
2 24 2C 2D DA 00	
S 00 00 00 00 00	- Coin took too long in coin chute
R 00 00 00 00 00	- Wrong exit after credit issue.
4 24 2C 2D DA 03	
4 24 2D 2D DB 03	
2 23 2D 2C D9 00	
2 25 2C 2C DC 00	
2 24 2C 2D DA 00	
4 24 2D 2D DB 03	

Note: The internal sequence for parameter checking is 1.) diameter, 2.) code, 3.) edge metal-S, 4.) edge metal-A, 5.) center metal. Coin memory is checked in the order of 1-6 for a match.



## Coin Acceptors (cont.)

The "Thresholds" line shows the sensitivity levels set for the 4 X-Mark optical sensors, the three diameter optical sensors, and the two credit optics sensors. These values will be between one and eight normally. The "Tank Calib" line shows the value of the inductive sensor reading when the last "learn" was performed, and what it is now in two different configurations. These should be in the 40s or higher. The "Sys Config" byte will normally be 00 for "inhibit low" and 80 for "inhibit high" on the Inhibit input line. The remaining timing values should be self explanatory.

View the Report Screen: Send the "R" command to see the coin data stored in memory and the operating parameters for various sensors and the timing of the credit pulse and other signals.

Change Inhibit Line Logic: Xeptors have a hardware inhibit line that is used to prevent acceptance of coins even when power is applied to the unit. When inhibited, the Xeptor LED will flash amber color to indicate the inhibit state. Send the "I" command to change to "inhibit high" or send the "i" command to change to "inhibit low". After doing so, you must send the "S" command to save the new configuration to nonvolatile memory.

Change Credit Pulse or Tilt Timing: The "Pccdddt" command is used to change the output credit pulse width (cc), the diverter output option delay and pulse width (dddd) and the tilt time. Assuming you do not have a diverter option and you would like the credit pulse to be 34ms (22 hex) and the self inhibit after a tilt to last four seconds (12/3 sec P 0C hex) then you would enter the command "P2200000C", followed by the "S" command to save the new configuration to nonvolatile memory.

Increase X-Mark Code Reading Security: Use this command to cause the Xeptor to increase the X-Mark reading security (have higher standards for acceptance) to knock out tokens which may have minted text or graphics which may, at least in part, mimic X-Mark facet reflections (only V3.0p or after). Bits 4 and 5 in the SysConfig byte control the X-Mark reading security features. Assuming that the inhibit logic is set for inhibit high (stored in bit 3 of SysConfig) and you wanted to set both X-Mark reading security bits (which raise the signal threshold level and require the mark be seen on both the leading and trailing edge of the coin), you would send the command "s38" followed by the "S" command to save the new configuration to nonvolatile memory. If you additionally wanted tighter metal alloy tolerance, use "s78".

Thickness and Diameter Adjustment: The X-10 Xeptor significantly raises the ability to measure and discriminate between coins through precision optical diameter measurement sensors, edge and center of coin metal alloy measurement, and X-Mark optical sensors

to read minted-in codes on the surface of the coin. To benefit from these new measurement capabilities we must also do a little better in coin position control than formerly required when only metal alloy was being measured. One cannot expect imprecise coin position control to allow precise and repeatable measurement of the coin properties any more than one could expect an accurate measurement of the length of a fish if you won't put the ruler up against the fish.

Thickness Setup: Figure 1 of the X-10 Xeptor is a side view showing a series of eight holes and a sliding adjustment with a detent that centers itself over one of the selected holes. The dimensions referring to each of the eight holes is the chute thickness achieved at each position of the sliding adjustment. A good rule of thumb would be to set the adjustment for .010" to .020" more than the thickest coin in the intended coin set.

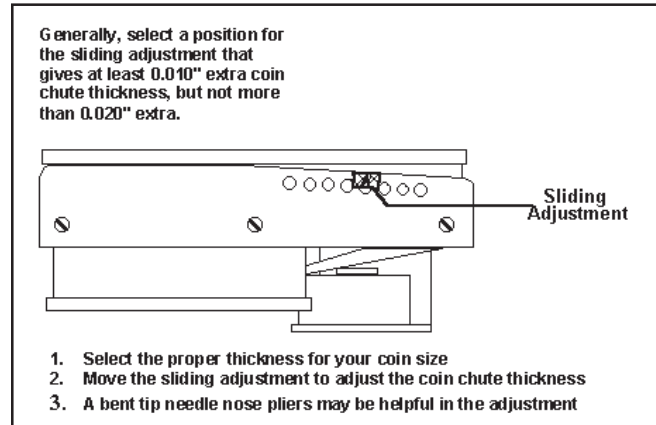

Figure 1

Diameter Setup: To control coin centering over the optical and inductive sensors, install the appropriate pair of clip-on coin chute edge guides as shown in Figure 2. The resultant coin chute width should be no more that about .060" wider than the coin if it has X-Mark codes. Without X-Mark codes, it may be as much as .23" wider. A single drop of silicone adhesive is recommended on each to ensure they are not accidentally knocked out.

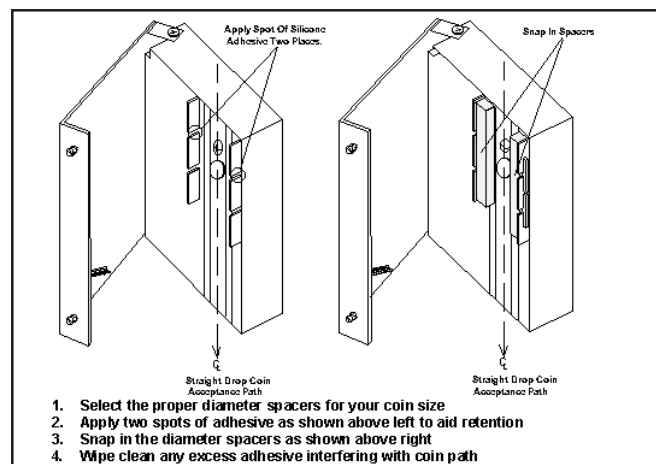

Figure 2

## Bill Acceptors



JCM American Corporation • 925 Pilot Road, Las Vegas, NV 89119 • Tel: (702) 651-0000, Toll Free: (800) 683-7248, Fax: (702) 644-5512 • www.jcm-american.com

### JCM® WBA-SS

Power Requirements: Voltage Range, 95 to 135 VAC with power supply 50 to 60 Hz, or 12 VDC max 20 VA.

Magazine capacity 600 notes.

Operating temperature recommended 0° to 45° C.

Adjustable Bill Slot: The WBA-SS has the ability to read a wide range of bill sizes. Four adjustment guides are available for bills that are 65 mm to 80 mm wide (Figure 1).



WBA-SS

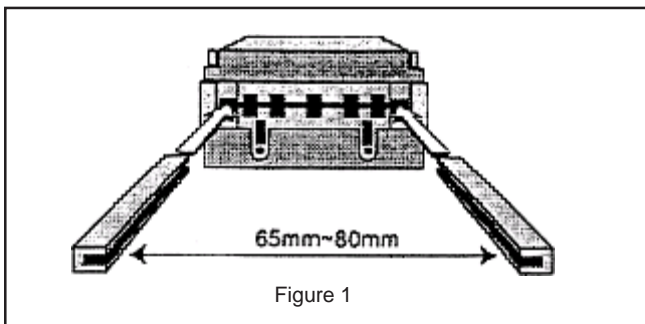

Figure 1

Collecting Bills: Collect bills by pressing the release lever and pulling the stacker box towards you (Figure 2).

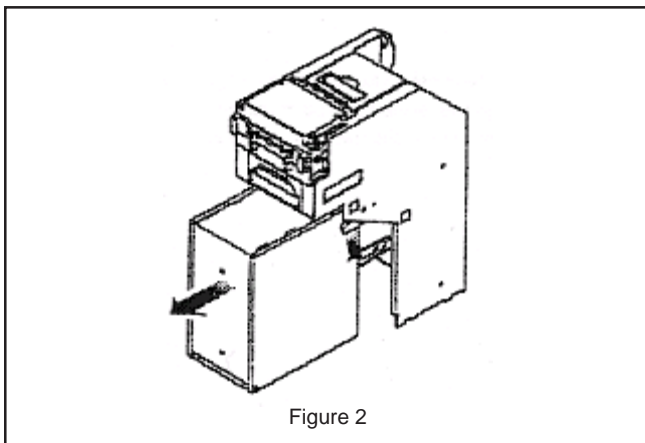

Figure 2

Open the stacker box cover and remove the bills inside (Figure 3).

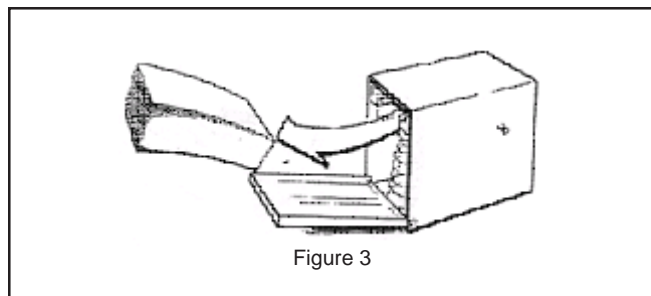

Figure 3

Bill Jams: Remove jammed bills from the bill head by moving the release catches on both sides of the head towards you. Open the acceptor head to access the jammed bill (Figure 4).

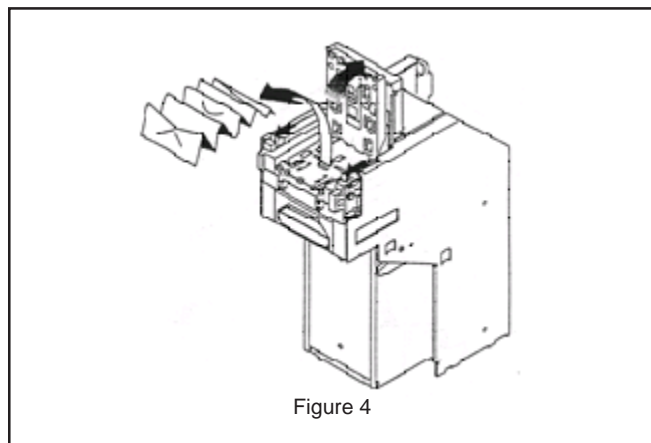

Figure 4

Remove jammed bills from the transfer area by pulling the access lever and opening the top cover (Figure 5).

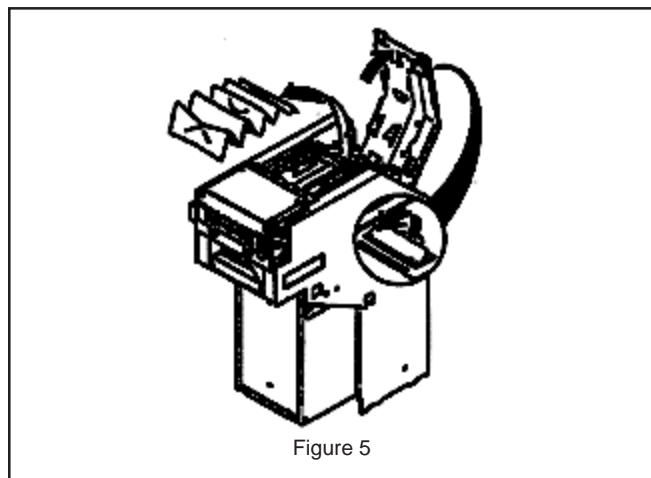

Figure 5

Occasionally, a bill jams near the inlet of the stacker box. Push the release lever of the stacker box and remove it to access the jammed bill (Figure 6).

## Bill Acceptors

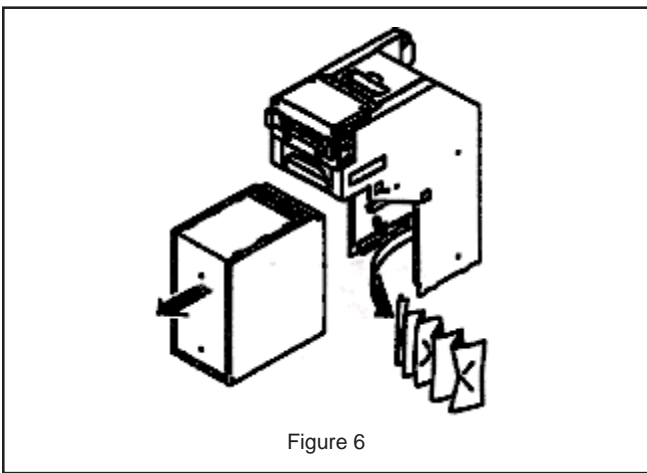

Figure 6

Interface: The WBA-SS uses an ID-003 interface. The ID-003 interface is a bidirectional serial interface. The machine is able to receive status reports from the WBA in response to appropriate commands (Figure 7).

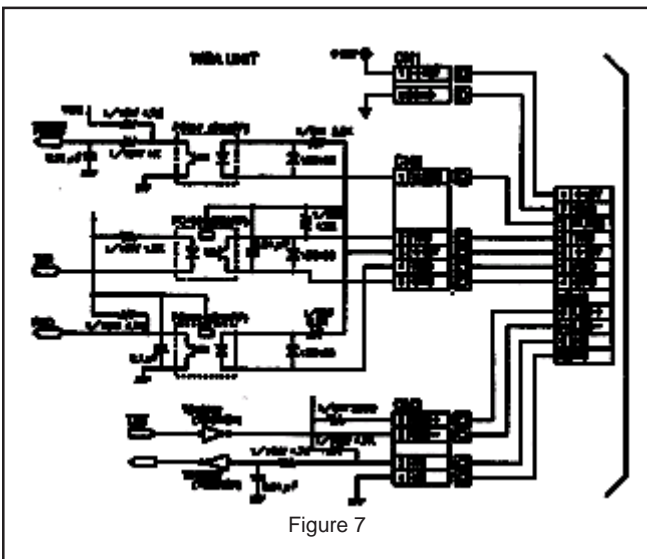
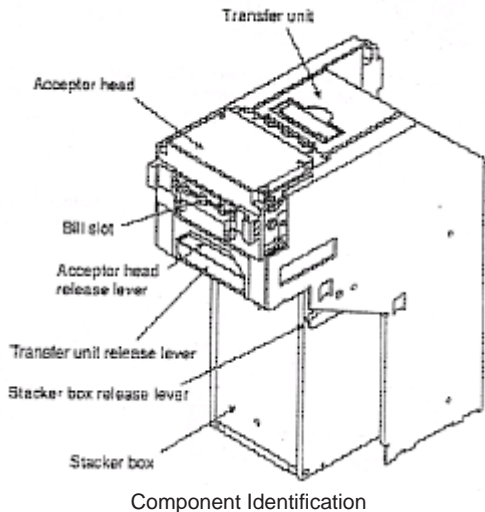
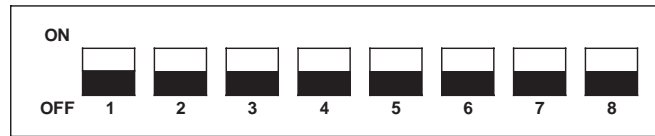

Figure 7



Component Identification

## US dollar (\$) DIP Switch Settings



WBA-10/11/12/13 ID-003							
SW-1	SW-2	SW-3	SW-4	SW-5	SW-6	SW-7	SW-8
DIR	\$1	\$5	\$10	\$20	\$50	\$100	OFF

(DIR) \*ON\*: 2-WAY ACCEPTANCE (IF WITHIN FIRMWARE)  
 \*OFF\*: 4-WAY ACCEPTANCE (IF WITHIN FIRMWARE)

## Troubleshooting

Description	Probable Cause	Possible Solution
Bill Rejection	DIP switches not set properly	Set DIP switches
	Roller and/or belts are excessively dirty	Clean head and rollers with mild soap and water solution
	Denomination disabled on game	Check game options
	Credit limit not set properly on game	Set credit limit for proper acceptance
	Cashbox is full, or not installed properly	Check and verify cashbox condition
	Sensors out of calibration, unit not calibrated after software upgrade	Calibrate unit using proper procedures
No Activity		Check for proper software/ID protocol
	No power to the unit/No LEDs visible	Check Power source, pins, wires and connector
	Will not start acceptance procedure/cycle	Check for proper software usage/ID protocol
	Cycles, but will not accept bills	Check for proper DIP switch and game settings
	Acceptor in an error status	Run standalone test to verify
	BAD CPU board, no lights on CPU board	Replace CPU board, or change out unit
Unit out of calibration	Calibrate unit using proper procedures	

## Stand-alone Test Mode

Accomplish this function by applying power to the unit's transport and head only.



**NOTE:** Perform this test outside the game using an extension harness, or power supply hookup.

- Remove power.
- Prior to starting, set the DIP switches. Place DIP switches 1, 2, 3 and 8 in the ON position.
- Apply power.
- Turn DIP switch 8 OFF. The unit should cycle briefly.
- The unit is now ready for the test.

# Peripherals

## Bill Acceptors (cont.)

- Insert a known bill/note.
- The bill/note will either go completely through, or be rejected.
- If the bill/note rejects, check calibration. Recalibrate if necessary. If the unit still rejects, there is a possible sensor problem, or incorrect software version. See Bill Return Codes.



**NOTE:** Verification that the unit is function properly can be done while in test mode.

- If the acceptor does not take the bill/note, check for power.
- When the unit cycles on power ON, this indicates power and forward motor operation.
- When a plain piece of paper is inserted and rejected, this indicates reverse motor operation.
- When various denominations of bills are inserted and accepted, this indicates the bill was successfully matched against the characteristics of the software.

### Bill Return Codes

# of Blinks	Description	Possible Cause
1	Crooked insertion	WBA-10, 11, 12, 13 sensor PT1 or PT2 not working WBA-20, 21, 22, 23 sensor PT3 or PT4 not working Bill inserted crooked
2	Magnetic pattern error	Dirty rollers/belts Bad mag sensor PCB
3	Entrance sensors bypassed	Sensor other than PT1 and PT2 or PT3 and PT4 detected the presence of the bill/note while in standby
4	Dark-light ratio is below the fixed value	Reflective sensors may not be working
5	Bill not detected	Bill/note not detected by a sensor within a specified period HPC, HPL, HPR or feed in sensor
7	Photo sensor error	Bill/note may have a pattern not programmed or recognized in memory
8	Photo level error	The bill note may be dirty Overlapping bill/notes detected
9	Illegal bill/note	The bill/note does not fall into the range of acceptable bill/notes in program
11	Stacker level problems	Solenoid not working Sensor may not know position of the stacker lever
12	Timing error	The timing is degraded between the sensors that track the bill/note movement
13	Bill/Note length error	Bill/note is torn Registration on bill/note is too short
14	Color pattern error	Color pattern on the bill/note is incorrect

## Auto-Calibration - Sensors

Description: Calibration sets a starting reference point for all optical sensors within the unit. This can be done at the host unit, or at the work bench with just a power source.

When to Calibrate:

- After the acceptor's components have been disassembled for repair.
- After a sensor board has been replaced.
- Whenever bill/note acceptance is degraded.
- During scheduled preventative maintenance (see Module 4, Periodic Maintenance)
- When upgrading/downloading software.

Procedure:

1. Remove transport unit with head.
2. Set DIP switches 5, 6, 7, and 8 to the on position, all others to the off position.
3. Connect transport unit with head to a power source - either the host machine, or adaptive power supply.
4. Listen for activation of the transport motor - forward and reverse for up to two seconds, then stop - READY.
5. After inserting the calibration paper, black paper first, the unit will carry the paper forward/reverse several times. When the process is complete, the unit will return the paper.



**NOTE:** Calibration paper may be purchased from JCM American directly by calling the Parts Sales department at (702) 651-3445 and requesting part number #501-000032.

6. Wait a few moments to allow for complete transfer of calibration data to be stored in memory. This is indicated via the LED on the test harness, or the bezel light on some applications with fast blinks.
7. Unsuccessful calibrations: Check the lenses. Retry calibration. If necessary, refer to the Error Conditions table following. Additional testing/troubleshooting may be required.



**NOTE:** Recalibration is required after installation of a new CPU.



## Bill Acceptors (cont.)

### Auto-Calibration Error Conditions Table

Look at the indicator LED connected to the test harness, or the bezel light. If the LED blinks from one to 11 times at  $\frac{1}{2}$  second intervals, an error exists.

Count the number of blinks and match the table following. If a count was missed, it will repeat after a one-second pause.

# of Blinks	Error Found During Calibration
1	Entrance Lever Error
2	Solenoid Error
3	Entrance Sensor Error
4	Transport Jam
5	Gain Error - White or Black Level
6	Digital/Analog Error
7	Bar Code Sensor Error
8	Acceptor Head Error
9	Magnetic Setting Error
10	Write-In Error
11	Black Level Error

## JCM® SENTRY™ - Intelligent Bezel



SENTRY™ Intelligent Bezel

The SENTRY bezel attaches to the WBA bill acceptor to provide both the machine user and slot technicians improved information about the operation of the bill acceptor.

For the slot user, the SENTRY has an animated display of green arrows on the bezel platform going into the bill acceptor that shows the unit is ready to accept bills or barcode coupons. While it is validating a bill or coupon, the arrows move from side-to-side. It also displays the denominations currently acceptable by the bill acceptor on the platform. The last bill entered is identified by the appropriate denomination light changing to orange.

When there is a problem requiring immediate attention, a flashing blue icon of an ambulance blinks on the front of the bezel and the bill acceptor shuts down. If a red icon also lights up, this gives the slot technician more specific information about the problem. On the standard bezel, the icons are a key, a crossed circle, an eye, and a crossed hammer and wrench. There is also a large JCM logo, which indicates the cashbox is full when lit.

Dimensions: 55 mm x 114 mm x 30 mm.

Note Acceptance: Accepts notes from 67 mm to 81 mm.

Features:

- Clearly indicates acceptor status, using graphic icons.
- Shows currently enabled denominations and/or bar code.

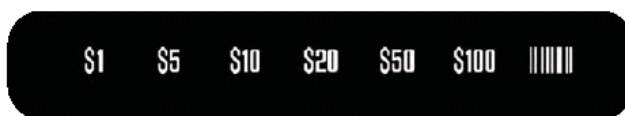

- Displays denomination of last-inserted bill.
- Runway light pattern indicates “Ready” (front to back) or “Processing” (side to side).
- Brilliant blue trouble light is easily visible from a distance.

## Bill Acceptors (cont.)

- Easily installed as a retrofit on most machines.
- Low-cost, low-maintenance design.
- Controlled directly by the bill acceptor - no changes to game software necessary.

### Installation Instructions

1. Remove the transport from the frame.



Figure 1

2. Remove the existing faceplate by opening the WBA transport and removing two screws. Disconnect the 4-wire harness from the transport (Figure 1).

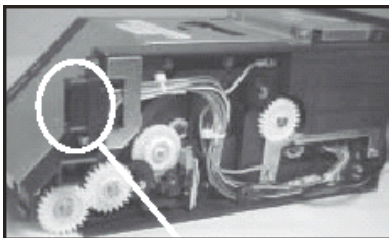
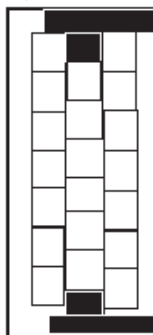

Figure 2

3. Disconnect the existing wire harness (Figure 2), then remove the two screws securing the connector on the rear of the transport.



4. Install the new wire harness, including the 3-wire connector going to the new faceplate. Secure the rest of the wires in the same manner as before.

5. Attach the 3-wire connector to the back of the circuit board (Figure 3).

6. Slide the circuit board into the SENTRY faceplate (Figure 4).

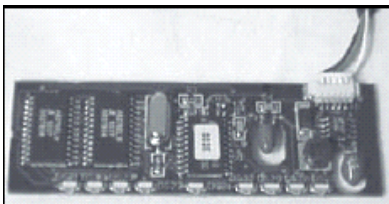

Figure 3

7. Push the faceplate down the front of the transport.

8. If desired, attach the SENTRY bezel to the WBA with the two supplies supplied in the kit.

9. Replace the transport in the frame (Figure 5).

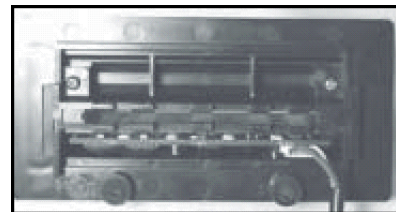

Figure 4

### Troubleshooting

When there is a loss of communication between the bill acceptor and the machine, a flashing blue icon of an ambulance blinks on the front of the bezel and the bill acceptor shuts down. If one of the four red icons light up with the flashing ambulance, it indicates a specific problem and the bill acceptor will shut down.

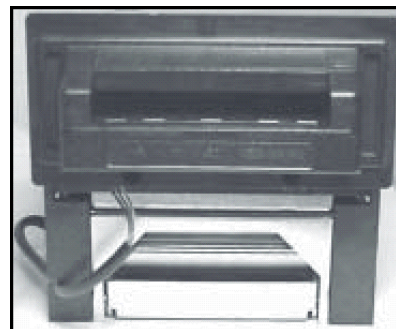

Figure 5

The following table details what the icons indicate when they light up along with the blue icon:

Icon	Message
Key	Problem with the cashbox. Someone with access to the cashbox must handle this problem.
Crossed Circle	ROM verification error, or a jammed motor. The bill acceptor will have to be returned to the manufacturer for repairs.
Eye	Possible cheat attempt. If the eye illuminates by itself, the WBA has rejected several bills in a short period of time. This will NOT disable the bill acceptor, but could mean calibration or cleaning is needed.
Crossed Hammer and Wrench	Minor error condition that can be repaired at the location.
JCM Logo	Cashbox is full.

## Bill Acceptors (cont.)

### JCM® DBV-200

Power Requirements: 12V DC.

#### Features:

- 4-way or 2-way acceptance of old and new bank notes, by DIP switch selection.
- 4-megabit memory
- Automatic calibration



DBV-200

### US dollar (\$) DIP Switch Settings

#### DBV-2000 Connection

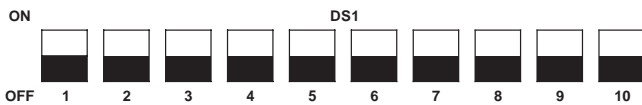

#### DENOMINATION / INTERFACE USE

WBA-10/11/12/13 ID-003							
SW-1	SW-2	SW-3	SW-4	SW-5	SW-6	SW-7	SW-8
DIR	\$1	\$5	\$10	\$20	\$50	\$100	OFF

NOTE: WHEN DIP SWITCHES ARE IN THE "ON" POSITION, IT DISABLES THE ACCEPTANCE OF THAT BILL DENOMINATION.



Switch	ON	OFF
1	With Stacker	Without Stacker
2	Must be set to OFF	OFF
3	Must be set to OFF	OFF
4	Must be set to OFF	OFF
5	Must be set to OFF	OFF
6	Test Mode	Normal

Pin #	Signal	Function
1	Power Supply	+12V/DC
2	Power Supply	Ground
3	NC	Not Used
4	NC	Not Used
5	NC	Not Used
6	NC	Not Used

Wiring

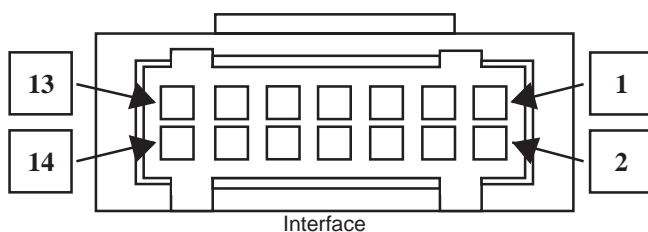
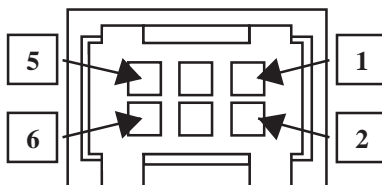

Pin #	Signal	Function
1	NC	Not Used
2	NC	Not Used
3	Busy	Indicates that the validator is in operation
4	Soft Reset	Signal to clear ABN (abnormal) or STKF (stacker full) signal.
5	Data	Terminal to output communication message.
6	CTS	Signal allows to send any communication message.
7	Ground	Ground
8	LED Power	Power supply to drive LED
9	NC	Not Used
10	Disable/Enable	Validator can accept bill when Low, and can not accept when High
11	RTS	Confirms the start of communication message.
12	NC	Not Used
13	NC	Not Used
14	ABN	To be output when the validator is in trouble, or when the stacker is full.

### Troubleshooting

Description	Probable Cause	Possible Solution
Bill Rejection	DIP switches not set properly	Set DIP switches
	Roller and/or belts are excessively dirty	Clean head and rollers with mild soap and water solution
	Credit limit not set properly on game	Set credit limit for proper acceptance
	Cashbox is full, or not installed properly	Check and verify cashbox condition
No Activity	Sensors out of calibration, unit not calibrated after software upgrade	-Calibrate unit using proper procedures -Check for proper software/ID protocol
	No power to the unit/No LEDs visible	Check Power source, pins, wires and connector
	Will not start acceptance procedure/cycle	Check for proper software usage/ID protocol
	Cycles, but will not accept bills	Check for proper DIP switch and game settings
	Acceptor in an error status	Run standalone test to verify
BAD CPU board, no lights on CPU board	Unit out of calibration	Replace CPU board, or change out unit Calibrate unit using proper procedures

### Stand-alone Test Mode

Set the DIP switches, then apply power to the unit to accomplish this function.



**NOTE:** Perform this test outside the game using the game power (6-pin) connector, or power supply hookup.

- Before applying power, turn DIP switch 6 to on.

# Peripherals

## Bill Acceptors (cont.)

- Apply power, then turn DIP switch 6 to OFF. The unit should cycle.
- The unit is ready for stand-alone testing.
- Insert a bill/note. The bill/note will either be accepted and go complete through the bill head, or be rejected.
- If the unit rejects the bill/note, refer to the Bill Return Codes table.
- If the unit will not take the bill/note, check the Abnormal Initialization Codes table.
- When the unit cycles on power ON, this indicates power and forward motor operation.
- When a plain piece of paper is inserted and rejected this indicates reverse motor operation.
- When various denominations of currency are inserted and accepted, this indicates the bill/note was accurately match against the characteristics of the software version.

### Bill Return Codes

# of Blinks	Description	Possible Cause
1	Crooked insertion	Bill was inserted crooked Entrance sensor malfunction
2	Magnetic pattern error	Error detecting magnetic pattern on a bill/note
3	Acceptor detected a bill while in standby	Detected the presence of a bill/note while in standby
4	Dark-light ratio is below the fixed value	Reflective sensors may not be working properly
5	Transport feed error	Bill/note not detected by the transport feed sensor within a specified period
7	Photo pattern error	Bill/note may have a pattern not programmed or recognized in memory Sensor may not be working properly
8	Photo level error	Dirty belts and/or rollers Double/overlapping bill detected The bill/note may be dirty
9	Return by inhibit settings	Bill/note does not fall into range of acceptable bills/notes, or denomination direction
10	Returned by host	Game program/settings will not accepted inserted bill/note
12	Detected another bill while a bill was still in stack mode	Entrance sensor malfunction Object blocking entrance sensor
13	Bill length error	Length of bill/note not within programmed specification
14	Color pattern error	Irregular color/shade/markings
15	Returned by other reasons (Magnetic error)	A combination error with magnetic sensors

### Abnormal Initialization Codes

# of Blinks	Description	Possible Cause
1	Cashbox Full	Cashbox may be FULL Motor not functioning Sensor not working Encoder gear cracked or split
2	Jam in Cashbox	Pusher mechanism may be jammed Stacker encoder sensor not functioning
3	Jam in Transport Unit	Cover open Stacker lever problem Bill remains in the carrying path
4	Jam in Acceptor Head	An object blocking sensors Sensor problem
5	Motor Speed Error	No signal from the acceptor's encoder sensor
6	Motor Stop Error	Motor not functioning Encoder gear cracked or split Encoder sensor not functioning
8	Solenoid Error	Solenoid not functioning Stacker lever not at home position
10	Cashbox Removed	No cashbox (SS units only) Cashbox not seated properly
12	Cheat Condition Detected	Sensors indicate possible sensor manipulation
15	D/A Adjustment Error	Possible calibration sensor error

### Auto-Calibration

1. Power OFF
2. Set DIP switch DS2: 4, 5, and 6 to ON.
 

ON OFF 1 2 3 4 5 6 7 8 9 10  
DENOMINATION / INTERFACE USE

ON OFF 1 2 3 4 5 6  
DIAGNOSTIC USE
3. Power-on the unit plugging in the 6-pin connector.
4. Head motor will cycle and stop indicating it is ready to calibrate.
5. Insert the DBV-200 calibration paper, black side first.



**NOTE:** Calibration paper may be purchased from JCM American directly by calling the Parts Sales department at (702) 651-3445 and requesting part number #057619.

## Bill Acceptors (cont.)

After inserting the calibration paper, the unit will carry the paper forward/reverse several times. When the process is complete, the unit will return the paper.

Look at the indicator for proper signals: 14-pin test LED, or the bezel light, if used. Fast blinks indicate acceptable calibration, and blinks from one to 11 intervals of  $\frac{1}{2}$  second indicate an error as described in the table following:

# of Blinks	Error Found During Calibration	# of Blinks	Error Found During Calibration
1	Entrance Lever Error	7	Barcode Sensor Error
3	Entrance Sensor Error	9	Magnetic Setting Error
5	Gain Error - White or Black Level	10	Write-in Error
6	Digital/Analog Error White Level Adjustments	11	Black Level Error



Mars Electronics International •  
1301 Wilson Drive • West Chester,  
PA 19380 • (800) 345-8215 Phone:  
(610) 430-2697 Fax: (610) 430-  
2694 • <http://www.meiglobal.com>

### ZT Series 1000

#### Features

- Exceptional Security: Through the use of multiple wavelength optical sensing and sophisticated data processing, the ZT Series 1000 bill acceptor sets the standard for rejecting invalid bills. Optical cross-channel sensors examine the bill path for foreign objects such as clear tape or strings. The LRC triggers an automatic "lock out" when separated from the unit for added security.
- High, four-way acceptance: Satisfy customers by accepting bills of all conditions. Bills can be fed in any direction, face up or down.
- Future flexibility in a flash: All U.S. models accept \$1, \$2, \$5, \$10, \$20, \$50 and \$100 bills. The ZT Series 1000 bill acceptor can be easily updated electronically to handle new currency designs.
- Reliable / low maintenance: With the streamlined recognition system, sensors are embedded under the smooth plastic bill path, and the magnetic head and pinch roller have been eliminated to dramatically reduce jams, debris build up and the need for cleaning.
- Bar code capability: Reliably accepts industry standard bar code coupons face up in both directions.
- Easy to use: The Recognition and Transport Unit (RTU) and the Lockable Removable Cassette (LRC) can be removed from the front with one hand. The RTU fully opens for cleaning and electrically connects automatically when inserted. An easily accessible toggle switch enables the operational mode to be changed to "test" or "setup" mode.



ZT Series 1000

#### Specifications

- Acceptance Rate: 95% or greater for US \$1 through \$100 bills
- Bill Insertion: Bill/lengthwise, four way (face up/down, either direction)
- Bar code Coupon/face up, either direction



# Peripherals

## Bill Acceptors (cont.)

- Transaction Speed: Approximately three seconds (from bill insertion to completed bill-stacking)
- Interfaces: Pulse and multiple serial protocols
- Power Sources: 12 to 40 volts DC
- Power Consumption: Standby: 3.0 Watts, Acceptance: 30 Watts peak, Stacking: 50 Watts peak
- Escrow: One bill/one barcode coupon
- Environment: Operating temperature: 5° C to 50° C, storage temperature: -30° C to 70° C, humidity: 5% to 85% relative humidity (non-condensing)

Bill acceptor components: The ZT1200 consists of three main components, the cashbox/LRC, the RTU and the chassis.

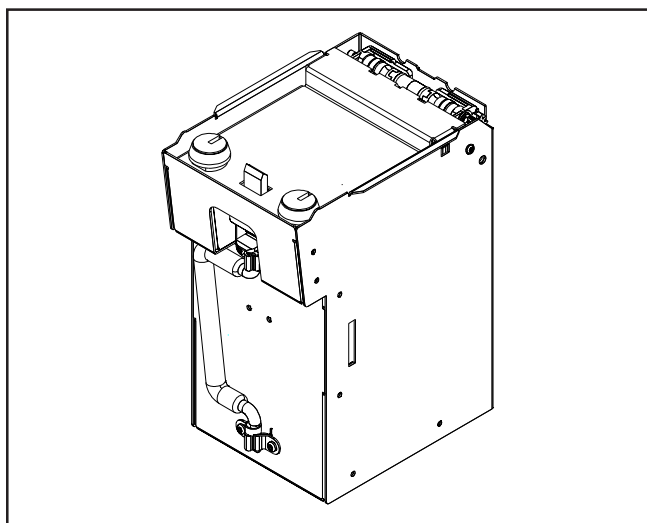

Cashbox/LRC

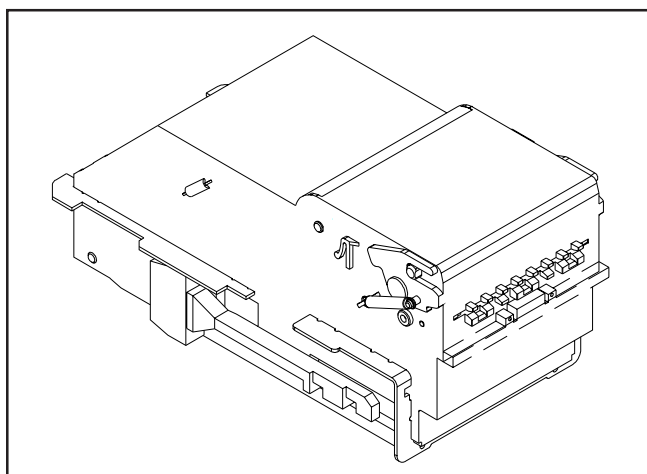

RTU

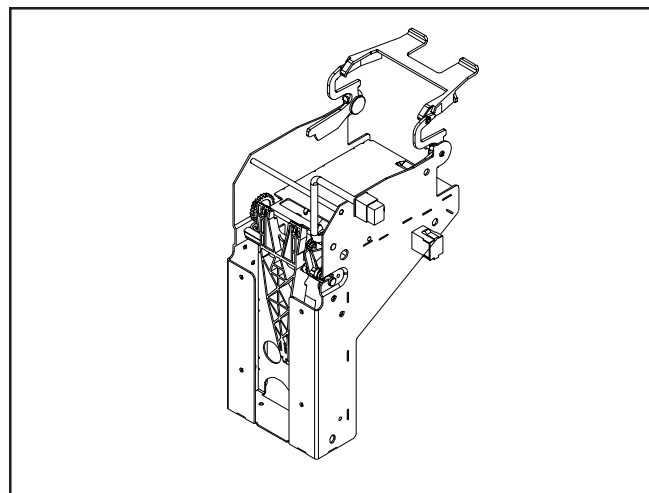

Chassis

### US Dollar (\$) DIP Switch Settings

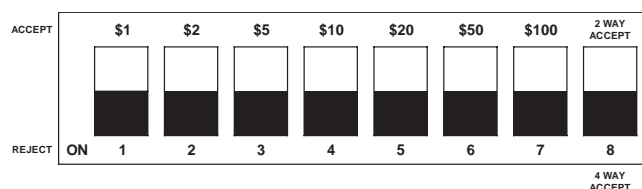

### RTU Removal

1. Pull forward on the release lever on top of the RTU. At the same time, pull forward on the RTU to its first locked position, about halfway out.
2. Pull forward on the release lever again. Pull forward on the RTU to remove it from the chassis.

### RTU Installation

1. Ensure that the bill path access areas are latched closed.
2. Slide the RTU into the chassis and push firmly to seat the unit.

### Modes

Interface Mode (normal operation): This mode is selected by placing the mode switch to the down position. Interface mode is the normal operating mode of the ZT1200 Bill Acceptor. This allows the unit to communicate with the machine that it is installed in so that it may accept bills and give credits.

Calibration Mode: This mode is selected by placing the mode switch to the middle position and cycling power. After the calibration is successfully completed, the ZT1200 will automatically return to Interface mode.

Boot Mode: This mode is selected by holding the mode switch in the up position while cycling power to the

## Bill Acceptors (cont.)

ZT1200. Boot mode is a special mode, which is reserved for factory use and field software upgrades. This unit will not accept bills or give credits when in this mode. To exit Boot mode, return the mode switch to the Interface mode position.

**Test Mode:** The test mode allows testing of the unit without credits being communicated to the host machine. This mode is very useful for troubleshooting and other stand-alone testing of the bill acceptor.

Entering the Test Mode:



**NOTE:** Bills will be accepted, but credits will not be given in test mode. Ensure that test mode is properly exited before placing the bill acceptor back in service.

1. Power up the ZT1200 in Interface mode.
2. After the unit performs a run-and-stack operation, wait at least an additional 10 seconds before performing the next step.
3. Hold the mode switch in test mode position.

The ZT1200 will now accept and stack bills, but no credits will be issued on the host machine.

To Exit the Test Mode:

1. Release the mode switch and return it to the Interface mode position.
2. Remove the RTU.
3. Replace the RTU (the unit will perform a run-and-stack).

The unit is now ready for use.



**NOTE:** The cashbox must be in place for bill acceptance.

**Coupon Mode:** This mode is selected by toggling the mode switch to the up position. This mode allows the default settings to be changed in the ZT1200 bill acceptor. These settings are used when switches 1-7 are in the OFF position on the bill option switch. The factory default coupon settings are \$1, \$2, \$5, \$10, \$20, \$50, and \$100s enabled with four-way acceptance. Coupon mode will only allow a onetime try for coupon configuration. After an attempt, the ZT1200 will automatically return to Interface mode.

1. Turn bill option switches 1-7 to the off position.
2. To enter the coupon mode, toggle the mode switch to the up position one time.
3. Install the RTU into the machine and close the door. The unit will run-and-stack and then pulse the motor in reverse indicating coupon configuration mode is enabled.

Coupon Configuration:

1. Make copies of a coupon with a standard, carbon-based, non-color copier. Copies of the coupon are usable if cut to match the size of the following coupon.
2. Fill out the coupon using a #2 pencil to complete the blocks for desired coupons. For correct operation, all eight lines must be completed. Fill in only one block per line. Do not mark the back of the coupon.
3. Complete lines one through seven to enable desired bill denominations. Complete one block for each denomination. High accept enables maximum bill acceptance. High security may be desired for locations where a higher level of discrimination is desired. Off will reject bills of the selected denomination.
4. Complete line eight to enable desired bill direction. Enable 1-or 2-way face up, or 4-way acceptance (which allows acceptance in all directions).
5. Insert coupon and verify settings were accepted.

**ACCEPTED:** Coupon will be held in escrow mode for approximately three seconds then returned.

**REJECTED:** Coupon will be immediately returned. Review instructions or try a new coupon.

Returning to Normal Operation:

1. Remove the RTU.
2. Change bill option switches.
3. Reinstall the RTU.

Calibration:



**NOTE:** A Mars ZT Calibration Kit is required to perform a calibration. Contact Mars at (800) 345-8215 and reference part number 251061008 for assistance.



## Bill Acceptors (cont.)

A calibration of the ZT1200 bill acceptor may need to be performed after certain maintenance procedures. Those procedures that require it will explicitly state that a calibration must be performed. As a general guide, any disassembly must be followed up with a calibration.

1. Turn off the bill acceptor and move the mode switch to the calibration position.
2. Turn on the unit and insert a piece of MARS calibration paper into the bezel of the bill acceptor within four seconds. After a few seconds, the calibration paper will be rejected.



**NOTE:** The bill acceptor will exit Calibration mode and return to Interface mode automatically four seconds after turning the power on if no calibration paper is inserted into the unit.

3. Remove the calibration paper from the bezel. The RTU will perform a run-and-stack operation if the calibration was accepted. If the unit does not perform a run-and-stack, the calibration data was not accepted. In this case, the calibration paper must be re-fed.



**NOTE:** If, after several attempts, the unit does not perform a run-and-stack, the bill acceptor may require additional services.

4. Allow the ZT1200 to idle for at least 20 seconds following the run-and-stack operation. Ensure that all bills, calibration paper or other objects are removed from the bezel during this period.
5. Turn off the unit and place the mode switch to the Interface position.
6. Turn on the unit. A run-and-stack operation will be performed if ready for service.

## Troubleshooting

Description	Probable Cause	Possible Solution
Unit will not draw in bills	Jammed bill in bill path	Check bill path for jammed bill
	Cassette not properly seated	Remove the cashbox and reinstall
	RTU not properly seated	Remove the RTU and reinstall
	Interface connector not installed or faulty connection	Check interface connector
	Power connector not installed or faulty connection	Check power connector
	Mode switch not in Interface mode position	Turn the unit off, place the mode switch to the Interface mode position, and turn the unit on
	Unit disabled by machine	Check machine for errors Check machine doors
Unit does not give credit	Mode switch not in Interface mode	Turn the unit off, place mode switch to the Interface mode position, and turn the unit on
	Bezel option switch in wrong position	Return bezel option switch #1 to OFF position and cycle power
	Cassette jammed	Remove RTU, verify home flag is in UP position. If not, cassetted may be jammed. Remove cassette and verify proper operation by pushing in on silver pusher at cassette rear.
	Communication error	Turn power off and on to clear error
Unit jams	Cassette not properly seated	Remove the cashbox and reinstall
	RTU not properly seated	Remove the RTU and reinstall
	Gear missing	Remove the RTU, check for two gears on the left-hand side, and replace gear if missing.
	Defective cashbox (LRC)	Remove the RTU. Roll the chassis idler gear (left-rear of chassis) and check for slipping. Remove and reinstall cashbox. Recheck for slipping. If slipping persists, replace cashbox.
Unit draws bills in, but will not accept bills	Option switches not set properly	Refer to Option Switch Settings section
	Interface errors	Check controller/machine enabling of bill acceptor
	Unit in Calibrate mode	Check mode switch position section
	Communication error	Turn power off and check connectors. Turn power on.
	Bills inserted upside down	Check switch for 4-way
	Worn or non-genuine bills	Use cash in better condition
Unit runs motor, stacks three times, then goes out of service	Cassette not properly installed	Remove and reinstall cashbox
	Home flag unclipped or broken	Remove RTU and verify proper home flag action. Re-clip or replace home flag.
	Cassette present cherry switch pushing on stacker arm	Some applications may have a cherry switch mounted behind the bill acceptor to verify cashbox removal. Remove cherry switch and wire to cassette present wires from chassis main harness.
RTU runs motor seven times and unit goes out of service	Dirt in bill path	Clean bill path and recalibrate

## Bill Acceptors (cont.)

**Money Controls**  Money Controls • New Coin  
Street, Royton Oldham OL2  
6JZ United Kingdom • Phone:  
+44 161-6780111 Fax: +44 161-6267674 •  
www.moneycontrols.com

### Ardac WACS

The **Ardac WACS (World Acceptor Cassette System)** is a world-proven, self-contained note acceptor and cassette stacking system that offers high performance, high security and fast, trouble-free note handling for a wide range of applications.



Ardac WACS

Based on world-proven **Ardac** technology, **WACS** is designed for acceptance of virtually all the world's note currencies and can handle multiple currencies of varying sizes at the same time. EPROM or Flash memory is used to program up to 260 individual note profiles that allow reliable discrimination of up to 65 banknotes in four directions.

**Ardac WACS** optically scans each note to determine authenticity and denomination, resulting in very high security, and also incorporates an internationally proven optical and mechanical anti-stringing design to protect against fraudulent activity. Individual notes may be inhibited from normal acceptance, giving operational flexibility and enhanced security when needed. Accepted notes are routed and stacked within the removable, and optionally lockable, cassette. This has a capacity to hold up to 550 street-grade notes, and, with no motor or electrical connectors, is ideal for use as an interchangeable unit.

The modular **Ardac WACS** comprises the acceptor and cassette mounted within a steel chassis that allows simple location of the unit within a host machine. The acceptor and cassette can be easily removed from the chassis and opened for periodic inspection or cleaning without the use of tools, simplifying general maintenance. Advanced maintenance and system monitoring is performed using the built-in diagnostics function in association with a PC and Ardac Host Simulator interface.

#### Features:

- High-speed, high-performance solution
- Truly global – accepts most of the world's note currencies

- Field update of note sets
- Handles multiple currencies at the same time
- Optimum in-service time
- Quick and easy to use by the end user.
- Very high first-time acceptance rate of street-grade banknotes
- Multiple, precision optical and magnetic sensors
- Automatic calibration of sensors for high performance
- Optical and mechanical anti-stringing design
- Alternative programming methods – EPROM replacement or download
- Compact, modular system, front or rear entry
- Built-in diagnostics
- Cassette holds up to 550 street-grade banknotes.

#### Specifications

Dimensions	Acceptor	Cassette	Chassis
Height	90mm (3.520")	204mm (8.042")	316mm (12.442")
Width	107mm (4.210")	88mm (3.476")	116mm (4.588")
Depth	229mm (9.000")	202mm (7.940")	180mm (7.100")
Weight	2.2kg (4.75lb)	2.3kg (4.90lb)	1.6kg (3.50lb)
<b>Note Size</b>			
Minimum Width		62mm (2.443")	
Maximum Width		83mm (3.270") [85mm (3.350") option]	
Minimum Length		120mm (4.728")	
Maximum Length		172mm (6.777")	
<b>Cassette Stacking Capacity</b>			
Up to 550 street-grade notes			
<b>Environmental</b>			
Temperature Range:		0°C to 60°C	
Operating			
Storage		-30°C to 60°C	
Humidity Range		Up to 90% RH non-condensing	
<b>Electrical Interface</b>			
Voltage: Nominal		12 - 24Vdc range	
Current:	@ 12Vdc		@24Vdc
Typical (running)	2.0A		820mA
Minimum (idle)	400mA		270mA
Maximum	4.0A		1.6A
<b>Operational Specification</b>			
65 notes x 4-ways, 260 profiles			
Automatic calibration of sensors for high performance			
Vend time less than 3.25 seconds			
Individual bill/note inhibit using 8-position DIP switch			
Easy access to not path for inspection and cleaning			
Diagnostics via RS232 ASCII serial interface			
<b>Communications Interface</b>			
Ardac-2 serial protocol (RS232)			
<b>Security</b>			
Ardac WACS incorporates an optical and mechanical anti-stringing design to deter and protect against fraudulent activity, such as pullback manipulation, thus providing optimum security.			

# Peripherals

## Hoppers

Bally Gaming and Systems products may use the XS-1200 Standard hopper. It also may use hoppers manufactured by Asahi Seiko, Inc.

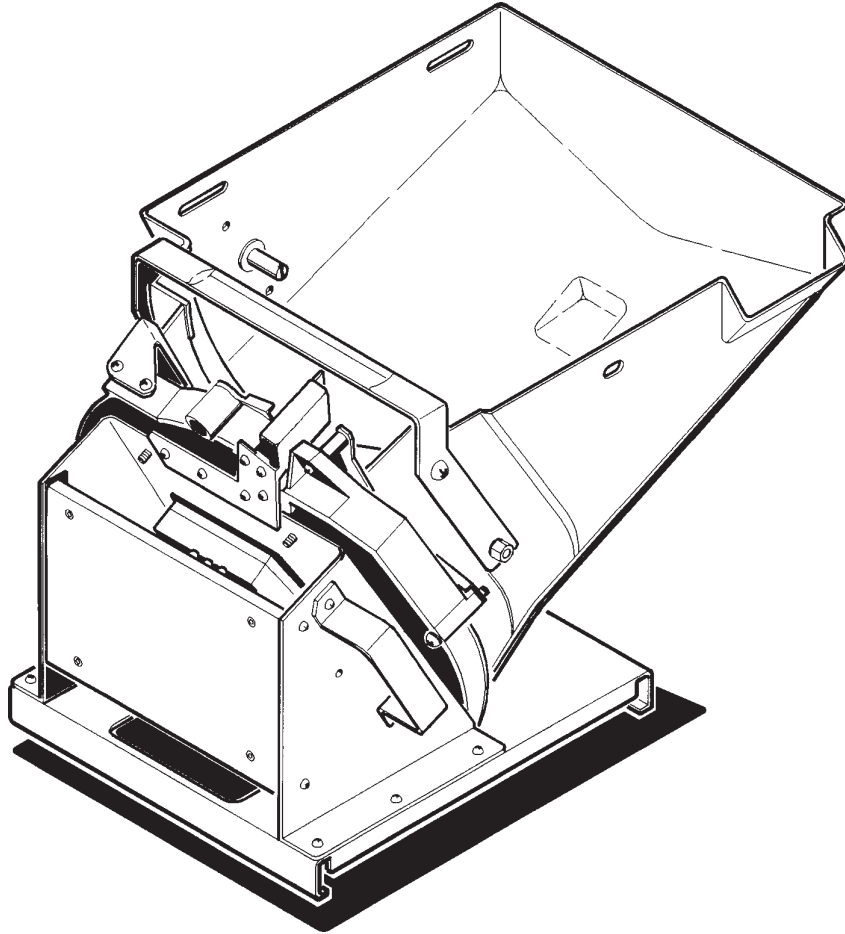

Bally XS-1200 Standard Hopper

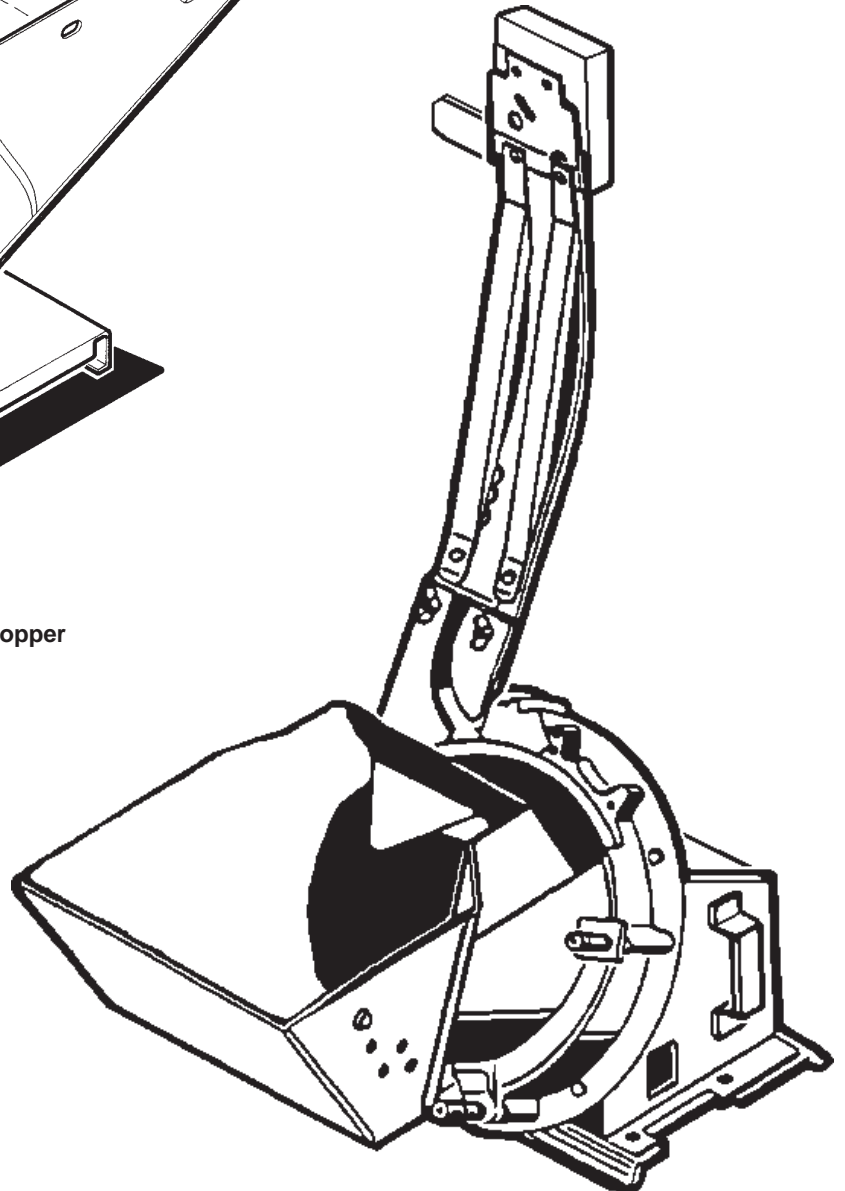

Asahi Seiko Hopper

## Hoppers (cont.)

### Bally Gaming and Systems XS-1200 Hopper (AS-04787-SERIES)

The XS-1200 design combines operator enhancements with the most advanced technology. It uses a multipurpose processor to provide an extremely efficient operation in a compact and simple design.

The primary focus of the engineering staff was to design the most dependable increased capacity hopper for the market and have greatly reduced the damage to components if a malfunction occurs, by adding several protective circuits. This is further enhanced by the power supply being included on a single printed circuit board for quick and easy repair.

#### Features

- Increased capacity for all denominations of coins. The recommended running levels are 4,200 25¢, 1,000 \$1 (or tokens) and 500 \$5 tokens.
- Larger motor for increased power, speed and reliability.
- Convenient switches for manual operation and testing.
- Advanced technology for easy repair.
- Easily adapted to various machine models.

#### XS-1200 Controller Board

The XS-1200 controller board is an intelligent control circuit. It handles all functions of the XS-1200 including pin wheel rotation, mixer rotation and coin un-jamming routines.

#### Switch Descriptions and Options

**Forward Switch:** Pressing the forward switch (sw2) will cause the pinwheel motor to rotate forward (payout mode). This switch will only function with the door open. Enabling this switch will also illuminate the green forward LED located at CR4. This LED will stay lit until the switch is released.

**Reverse Switch:** Pressing the reverse switch (sw1) will cause the pinwheel motor to rotate in reverse (clear jam mode). Enabling this switch will also illuminate the red reverse LED located at CR5 until the switch is released.



**NOTE:** The reverse spin on the pinwheel is slower than the forward spin, because the CPU on the control board sends a slower signal to prevent coins being forced underneath the hopper knife.

**Forward / Reverse (Mixer/Motor Test):** Pressing the forward switch (sw2) and the reverse switch (sw1) simultaneously will start the mixer motor, and illuminate the yellow mix LED located at CR3. The motor will remain on, and the LED will remain lit, until either switch is released.

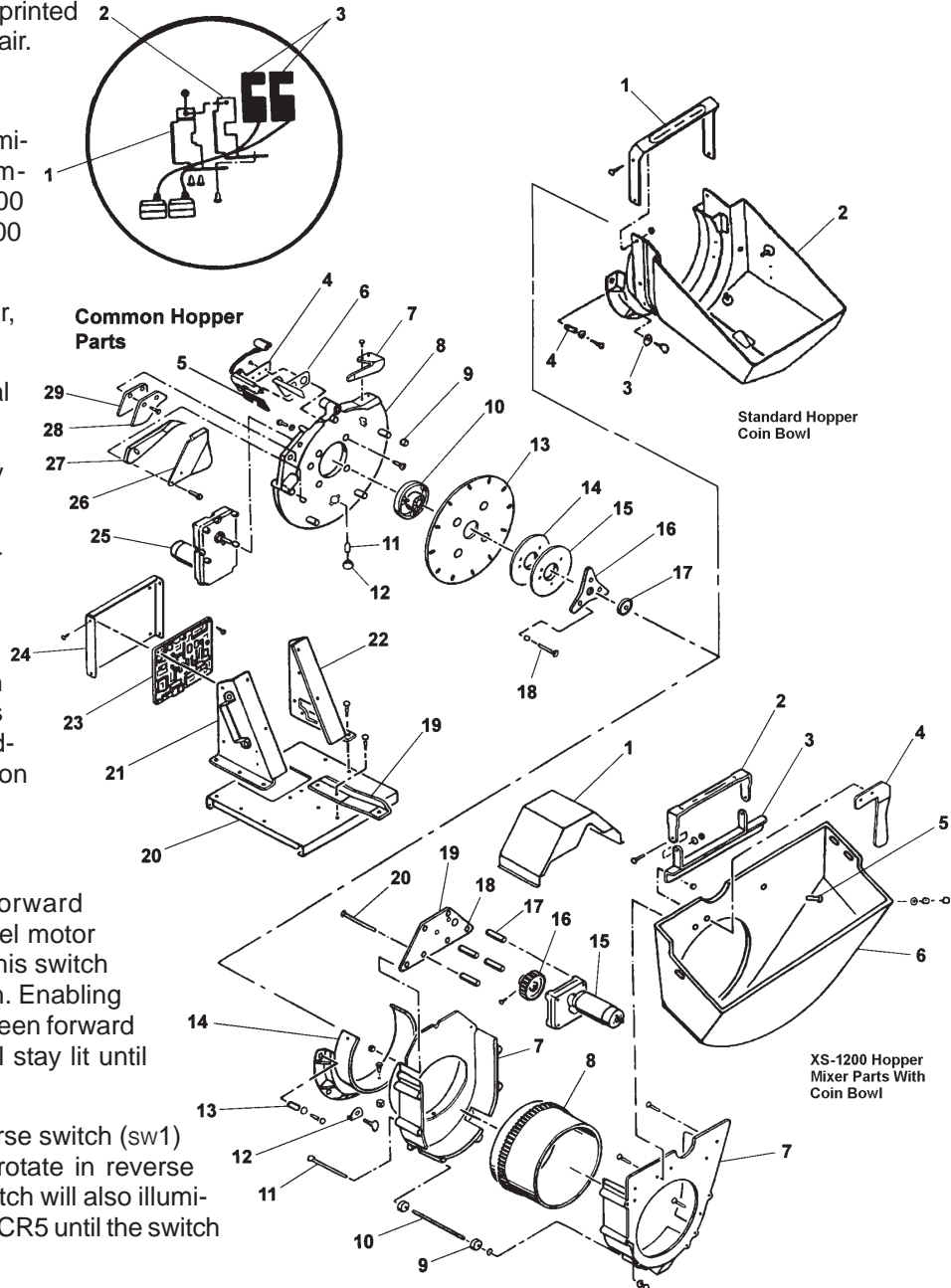

# Peripherals

## Hoppers (cont.)

XS1200 HOPPER PARTS			XS1200 HOPPER WITH MIXER PARTS		
ITEM	PART #	DESCRIPTION	ITEM	PART #	DESCRIPTION
1	P-09319-0512	Bracket, Outer Mounting	1	M-03082-001A	Cover, Mixer Drive
2	P-09319-0511	Bracket, Inner Mounting	2	P-06264-0309	Handle
3	E-00733-0008	Optic Switch Assembly (2)		TFPP-01032-1108	Screw
4	P-09319-0204	Bracket, Hopper Optic Guard, Outer	3	A-04349-0002	Bracket, Handle Mounting
5	E-00733-0008	Optic Switch Assembly (Single)		NLS-00832-1112	Nut (2)
	TFPP-00632-1114	Screw		M-00319-0001	Stop Nut,Elastic (2)
6	P-09319-0203	Bracket, Hopper Optic Guard, Inner	4	P-09295-002D	Baffle
7	P-00845	Wiper		NLS-00832-112	Nut (2)
8	M-03073-0002	Wheel Housing, Hopper	5	S-00463-0053	Pin, Level Contact (Probe)
9	S-00231-0978	Spacer		P-00800-0006	Washer (2)
10	M-03072-001B	Drive Coupling, Pinwheel, Hopper		NLS-00832-112	Nut (2)
11	S-02562-001A	Roller Shaft	6	M-03048-0013	Coin Bowl, V7K
12	M-03009-A001	Roller (3)		M-03048-0015	Coin Bowl, S6K
13	P-00842-011B	Pin Wheel, 12 Pin (1.00Token)		A-04394-0001	Grounding Stud
	P-00482-010B	Pin Wheel, 15 Pin (25¢)	7	AS-03368-0001	Assembly, Hopper Mixer Front/Back Bracket
	P-00482-009B	Pin Wheel, 16 Pin (5¢)	8	M-03047-001A	Mix Cylinder
	A-04308-001A	Pin Wheel (5.00 Token)	9	M-03066-001A	Roller (4)
14	P-00847-0024	Spacer, Shelf Wheel (5.00 Token)		P-02891-0006	Retainer Ring
15	P-00847	Shelf Wheel (25¢) .836" (21,23 mm) To .902" (22,91 mm) Diameter X .062" (1,58 mm) Width	10	S-02558-001A	Shaft Roller (2)
16	R-00526-0003	Agitator, 5¢ to \$1	11	TFPP-00832-1924	Screw (6)
17	S-02569-0002	Cup, Washer, Pin Wheel Hold Down	12	M-01348-0043	Thumbscrew
18	S-00231-0825	Bushing, Agitator Mounting	13	SP-00200-0203	Spring (2)
19	P-09278-0004	Bracket, Counter Balance Adjustment, Super (mixer) Hopper		MSPT-01032-110B	Nut (2)
	P-09278-0005	Bracket, Counter Balance Adj. Adjustment, V72,		PW-00010-0012	Washer (2)
	P-09278-0008	Bracket, Counter Balance		M-03074-001B	Adaptor
	NLS-25020-1112	Nut	14	NLS-00832-0112	Nut (2)
	MSOH-25020-1124	Screw		MSPT-01032-1108	Screw (3)
20	P-09277-001B	Platform Bracket, (mixer)		NLS-01032-1112	Screw (3)
21	P-09263-0005	Bracket, Hopper Mounting, Left	15	E-00119-0529	Mixer Cylinder Motor
	TFPP-00832-1106	Screw (6)		M-03069-001B	Drive Gear Hopper
22	P-09263-0006	Bracket, Hopper Mounting, Right	16	CPAO-01032-1804	Set Screw
	TFPP-01032-1106	Screw (6)		S-00231-0979	Spacer (4)
23	AS-03356-0363	Hopper Control Board	17	S-00231-0978	Spacer (4)
24	P-06629-523A	Bracket, PCB		NLS-00832-1112	Nut (2)
	TFPP_00832-1104	Screw (4)	18	R-00111-0029	Rubber Grommet For Elec.Wire
	LSPP-00632-1108	Screw (4)	19	P-09276-0002	Bracket, Drive Motor
25	E-00119-0532	Motor, Pinwheel, Hi-Torque, 24RPM	20	MSPF-00832-1132	Screw
26	P-00838-0011	Outlet Cover			
	P-00838-006B	Outlet Cover, 5¢ & 25¢			
	P-00838-0009	Outlet Cover, 5¢-50¢			
	P-00838-007A	Outlet Cover, 1.00 Token			
	P-00838-005A	Outlet Cover, 5.00-100.00 Token			
	P-00838-0008	Outlet Cover, 5.00-100.00 Token			
	P-00838-0012	Outlet Cover, 5.00-100.00 Token			
27	M-03068-0006	Knife, Coin, Up To 1.625" (41,28mm) Diameter			
	M-03068-0007	Knife, Coin, Over 1.625" (41,28mm) Diameter			
28	P-00839	Coin Deflector			
	P-00839-0004	Coin Deflector, 1.00, 5.00, 25.00, 100.00 Token			
	MSPF-0832-1106	Screw (2)			
29	P-09291-001B	Spacer, Deflector Plate			

STANDARD HOPPER COIN BOWL		
ITEM	PART #	DESCRIPTION
1	P-09334-002B	Handle
	M-03048-0015	Coin Bowl, S6K, V8K
	M-03048-0012	Coin Bowl, V7K
2	M-03048-0017	Coin Bowl, V7 Casino
	M-03048-0019	Coin bowl, V72
	S-00463-0053	Pin,Level Contact
3	P-09278-003A	Retaining Bracket
	M-01348-0043	Thumbscrew
4	SP-00200-203	Spring (2)



## Hoppers (cont.)

---

### Hopper Adjustments

Adjust Hopper Wiper: The wiper knocks off coins stuck together, which allows only one coin to pass. To adjust the wiper, follow these steps:

1. Turn the pin wheel to position a coin under the wiper.
2. Loosen both mounting screws and move the wiper edge up to the coin.
3. Tighten both screws just enough to allow the wiper to be moved in and out.
4. Slide a coin under the wiper edge and release it. The coin should fall down onto the shelf wheel. The wiper edge should be close to the coin, but not holding it.
5. Tighten the back screw, then the front screw, constantly checking the wiper position to the coin. Continue to tighten the back screw then the front until the wiper cannot be moved in or out. Do not overtighten the screws as the head of the screw will break off.

Adjust Hopper Knife Position: The forward edge of the hopper knife presses against the pin wheel and touches the edge of the shelf wheel. This allows no coin to wedge itself between the blade and the pin.

Removing the Mix Cylinder: The mix cylinder is used to agitate coins in the hopper to prevent coin jams. It can be removed for hopper maintenance or replacement if necessary.

1. Remove the gear cover.
2. There are three bolts used to secure the drive motor to the adaptor hopper. Remove the two bolts that are in the recessed openings, and pull the motor up and to the side.
3. Unscrew and remove the baffle.
4. Lift out the mix cylinder.

Hopper Probe Circuit: The hopper probe circuit consists of two hopper probes. The first probe is a stationary pin located at the bottom of the bowl. The stationary probe and the moveable probe are electrically connected when the coins in the bowl are touching both probes. When the coins in the hopper are grounding to the stationary probe, and are also touching the moveable probe, a signal is sent to the MPU board indicating the hopper is full. The signal triggers the diverter coil on the door so that coins will be diverted to the drop.

Setting the hopper probe circuit coin level

1. Fill the hopper with the desired number of coins. The coins should be either level with, or slightly above, one of the holes drilled into the side of the hopper coin bowl.
2. Activate the forward switch for approximately five seconds. This will agitate, and then settle, the coins in the bowl.
3. Insert the top probe into the hole that is level with (or just above) the amount of the coins in the bowl. This sets the coin level for the chosen probe location.

# Peripherals

## Hoppers (cont.)



6644 Paradise Road, Las Vegas,  
Nevada • 89119-3719 • Telephone:  
(702) 260-6666 • Fax: (702) 260-6493 •  
Toll Free: 1(800) 859-5353 • <http://www.asusainc.com>

### Asahi Seiko DH-750 Hopper, Model 53, Slant Top (AS-03105-SERIES)

#### Features

- Customization: The DH-750/U1 allows customers the flexibility to design around their requirements. They can choose exit direction, voltage, coin capacity, counting method and coin level detection as standard options.



DH-750 Hopper

- Serviceability: The DH-750/U1 was designed with the field service industry in mind. In the event a coin jam occurs, service techs can simply loosen the screws to clear the jam without damaging any parts that would otherwise require replacement. The use of Asahi Seiko's patented "back flow" system prevents coins from flowing back down the escalator causing miscounts and frequent coin jams.

#### General Specifications

Applicable Coin Sizes:	Diameter: 21.0mm – 38.0mm
	Thickness: 1.5mm – 3.3mm
Coin Capacity:	US 5¢: 1,300
	US 25¢: 1,000
	\$1 Token: 300
Dispensing Speed:	US 5¢: 400 coins/minute
	US 25¢: 380 coins/minute
	US \$1: 200 coins/minute
Coin Counting Method:	Proximity Sensor or Microswitch
Motor Voltage:	115VAC, 220VAC, 24VDC (Thermal Protector and Instant Stop device included on AC motors only)
Motor Rating:	5 Minutes
Current Consumption:	3.0A @ 115V AC
Operation Temperature:	-10°C - +60°C
Weight:	14.69 pounds approx. (AC motor)

DH-750 Model 53 Hopper Assembly

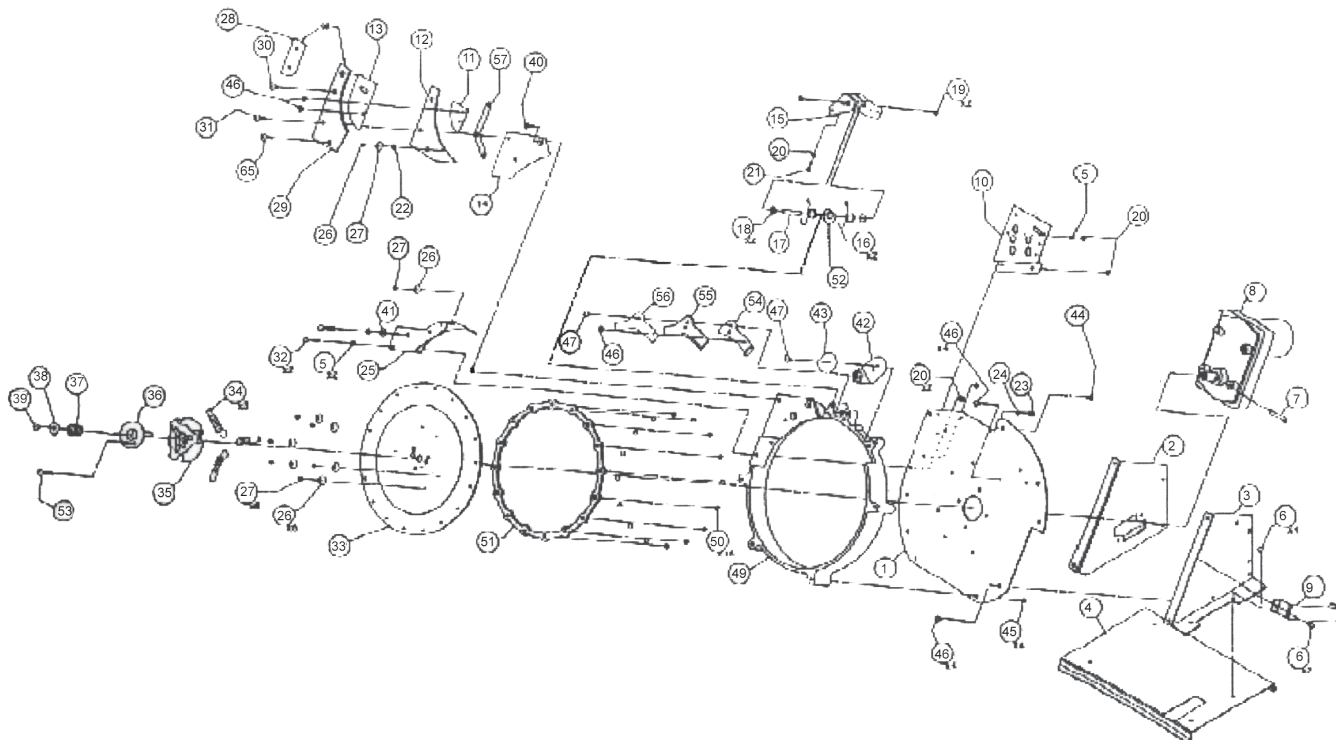



# Hoppers (cont.)



**NOTE:** Items without a Bally part number are not stocked by Bally.

## DH-750 MODEL 53, SLANT TOP COIN HOPPER

Item#	Bally Part #	Asahi Seiko Part #	Description	Item#	Bally Part #	Asahi Seiko Part #	Description
1		DH7991M025001	PLATE, CHASSIS	32	ASH-05000-0001	B4025HXSS	BOLT, M4x25, SS
2		DH7534M025002	FRAME, SIDE (R)	33	ASH-05000-0003	DH7001M005033	DISC, US 5¢
3		DH7534M025003	FRAME, SIDE (L)		ASH-05000-0012	DH7001M025033	DISC, US 25¢
4		DH7534M025004	PLATE, BASE		ASH-05000-0035	DH7001M10T033	DISC, \$1 TOKEN
5		W4000SW99	WASHER, M4 SPLIT	34	ASH-05000-0013	DH7001M025034	SPRING, STIRRING
6		S4006RHSW	SCREW, M4x6 W/SW	35	ASH-05000-0014	DH7001M025035	COVER, SPRING
7	ASH-05000-0005	DH7001M025007	PIN, MOTOR DRIVE	36	ASH-05000-0015	DH7001M025036	HOLDER, SPRING
8	ASH-05000-0040	DH7004M025008	MOTOR, 24VDC (DME44S7C-272)	37	ASH-05000-0016	DH7001M025037	SPRING, DISC
9		DH7001M025055	HANDLE	38		W4015FW10	WASHER, 4x15x1.0 FLAT
10	ASH-05000-0097	DH7101M025536	BRACKET, ESCALATOR MOUNTING	39	ASH-05000-0170	S4008LHSS	SCREW, M4x8 TRUSS HEAD SS
11	ASH-05000-0168	DH7101M005530	GUIDE, TRANSITION (R), US 5¢	40	ASH-05000-0108	S4015CS99	SCREW, M4x15 COUNTERSUNK
	ASH-05000-0094	DH7101M025530	GUIDE, TRANSITION (R), US 25¢	41		W4010FW10	WASHER, 4x10x1.0 FLAT
	ASH-05000-0044	DH7101M10T530	GUIDE, TRANSITION (R), \$1 TOKEN	42	ASH-05000-0029	DH7001M025073	SEPARATOR, COIN
12	ASH-05000-0169	DH7101M005531	GUIDE, TRANSITION (L), US 5¢	43	ASH-05000-0030	DH7001M025074	RETAINER, SEPARATOR
	ASH-05000-0095	DH7101M025531	GUIDE, TRANSITION (L), US 25¢		ASH-05000-0037	DH7001M10T074	RETAINER, SEPARATOR, \$1 TOKEN
	ASH-05000-0045	DH7101M10T531	GUIDE, TRANSITION (L), \$1 TOKEN	44		S4010HXSS	SCREW, M4x10 UPSET SF SS
13	ASH-05000-0077	DH7534M025529	COVER, TRANSITION (R)	45		S4015HXSS	SCREW, M4x15 UPSET SF SS
14:	ASH-05000-0096	DH7101M025534	PLATE, COIN SLIDE	46		S3010HXSS	SCREW, M3x10 UPSET SF SS
15	ASH-05000-0043	DH7101M025015	ROLLER LEVER, ESCALATOR	47		S4012HXSS	SCREW, M4x12 UPSET SF SS
16	ASH-05000-0006	DH7001M025016	SPRING, ROLLER LEVER	48		S4008HXSWS	SCREW, M4x8 UPSET SW SS
17	ASH-05000-0007	DH7001M025017	PIN, ROLLER LEVER	49	ASH-05000-0022	DH7001M025057	CAST FRAME
18	ASH-05000-0008	DH7001M025018	BEARING, ROLLER LEVER	50		DH7001M025058	06 BALL BEARING
19	ASH-05000-0112	W3000ER99	03 E-RING	51		DH7001M025059	RETAINER, BEARING
20		N4000HX99	NUT, M4	52		DH7001M025064	WASHER, ROLLER LEVER
21		B4012HX99	BOLT, M4x12	53		S4025LHSS	SCREW, M4x25 LARGE HEAD SS
22	ASH-05000-0113	W3008FW08	WASHER, 3x8x0.8 FLAT	54		DH7001M005070	PLATE, ADJUSTING, US 5¢
23	ASH-05000-0106	S3010RH99	SCREW, M3x10		ASH-05000-0026	DH7001M025070	PLATE, ADJUSTING, US 25¢
24	ASH-05000-0086	N3000HX99	NUT, M3			DH7001M10T070	PLATE, ADJUSTING, \$1 TOKEN
25	ASH-05000-0002	DH7001M005025	KNIFE, US 5¢	55		DH7001M005071	RUBBER, JUMP, US 5¢
	ASH-05000-0009	DH7001M025025	KNIFE, US 25¢		ASH-05000-0027	DH7001M025071	RUBBER, JUMP, US 25¢
	ASH-05000-0034	DH7001M10T025	KNIFE, \$1 TOKEN		ASH-05000-0036	DH7001M10T071	RUBBER, JUMP, \$1 TOKEN
26	ASH-05000-0010	DH7001M025026	BOSS, PLASTIC	56	ASH-05000-0004	DH7001M005072	COVER, JUMP, US 5¢
27	ASH-05000-0011	DH7001M025027	SCREW, BEVEL-HEADED		ASH-05000-0028	DH7001M025072	COVER, JUMP
28		DH7101M10T538	COVER, TRANSITION (L) \$1T	57		DH7514M025650	SHIM, TRANSITION (L) 0.3t
29	ASH-05000-0099	DH7101M025538	COVER, TRANSITION (L)			DH7514M10T650	SHIM, TRANSITION (L) 0.5t
30		S4012HXSS	SCREW, M4x12 UPSET SF SS	58		S4020HXSS	SCREW, M4x20 UPSET SF SS
31		S4025HXSS	SCREW, M4x25 UPSET SF SS				

DH-750 Model 53, Slant Top Bowl Assembly

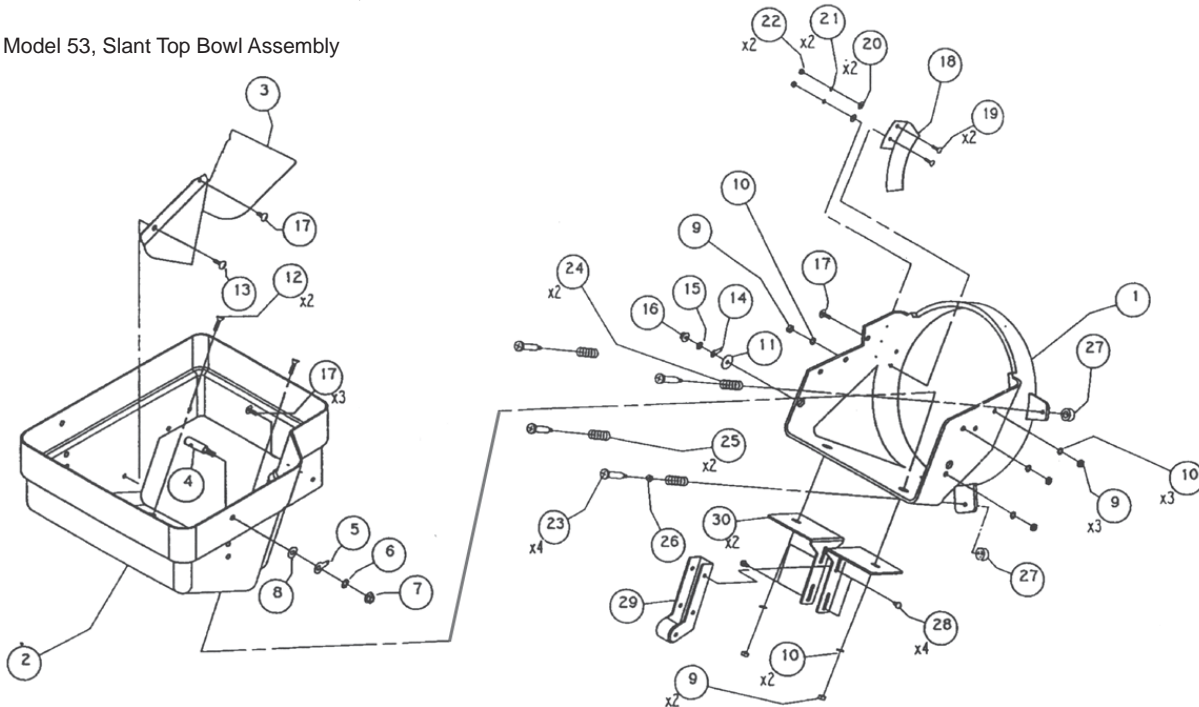

# Peripherals

## Hoppers (cont.)



**NOTE:** Items without a Bally part number are not stocked by Bally.

### DH-750 MODEL 53, SLANT TOP BOWL ASSEMBLY (PLASTIC)

Item#	Bally Part #	Asahi Seiko Part #	Description	Item#	Bally Part #	Asahi Seiko Part #	Description
1		DH7031M025322	SCOOP, ALUMINUM	16		N4000SN99	NUT, M4 SHOULDER
2		DH7534M025950	BOWL, HOPPER (PLASTIC)	17		S4012LH99	SCREW, M4x12 LARGE HEAD
3		DH7031M025046	PLATE, REGULATOR	18	ASH-05000-0021	DH7001M025052	INSULATOR
4		DH7011M025153	.PROBE PIN	19		S3010LH99	SCREW, M3x10 LARGE HEAD
5		DH7011M025093	05 WIRE TERMINAL	20	ASH-05000-0113	W3008FW05	WASHER, 3x8x0.5 FLAT
6		W5000SR99	WASHER, M5,STAR	21		W3000SW99	WASHER, M3 SPLIT
7		N5000SN99	NUT,M5 SHOULDER	22	ASH-05000-0086	N3000HX99	NUT, M3
8		W5012FVW08	WASHER, 5x12X0.8 FLAT	23	ASH-05000-0018	DH7001M025047	SCREW, BOWL MOUNTING
9		M4000HX99	NUT, M4	24	ASH-05000-0019	DH7001M025048	SPRING, BOWL MOUNTING, UPPER
10		W4000SW99	WASHER, M4 SPLIT	25	ASH-05000-0020	DH7001M025049	SPRING, BOWL MOUNTING, LOWER
11		W4015FW10	WASHER, 4x15x1.0 FLAT	26	ASH-05000-0104	N4006HX99	NUT, M4 SMALL
12	ASH-05000-0108	S4015CS99	SCREW, M4X15 COUNTERSUNK	27	ASH-05000-0038	DH7001M10T081	COLLAR, SPACING (\$1 TOKEN ONLY)
13	ASH-05000-0109	S4015LHSS	SCREW, M4X15 LARGE HEAD SS	28		S4008RHSF	SCREW, M4x8 W/SW & FW
14		DH7011M025307	04 WIRE TERMINAL	29		DH7031M025324	ROLLER, SUPPORT
15		W4000SR99	WASHER, M4 STAR	30		DH7534M025325	BRACKET, SUPPORT

DH-750 Model 53, Slant Top Escalator Assembly

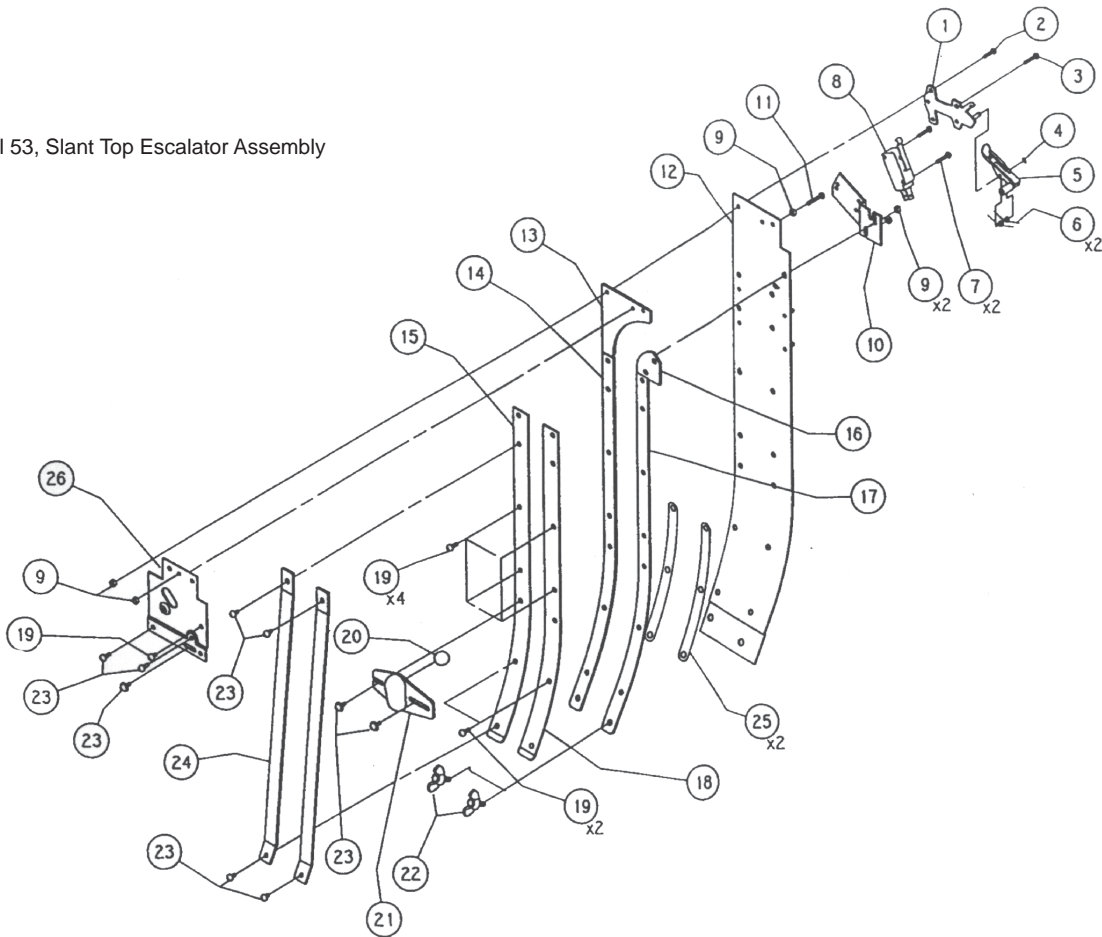

# Hoppers (cont.)



**NOTE:** Items without a Bally part number are not stocked by Bally.

### DH-750 MODEL 53, SLANT TOP ESCALATOR ASSEMBLY

Item#	Bally Part #	Asahi Seiko Part #	Description	Item#	Bally Part #	Asahi Seiko Part #	Description
1	ASH-05000-0020	DH7101M025516	PLATE, ACTUATOR MOUNTING	14		DH7534M005604	RAIL, GUIDE (L) 2.5t
2		S3010HXS	SCREW, M3x10 UPSET SW SS			DH7534M025604	RAIL, GUIDE (L) 2.0t
3		S3012HXS	SCREW, M3x12 UPSET SW SS			DH7534M10T604	RAIL, GUIDE (L) 3.2t
4	ASH-05000-0111	W2000ER99	02 E-RING	15		DH7534M025606	COVER, GUIDE (L)
5	ASH-05000-0088	DH7101M025522	ACTUATOR, M/S INBOARD	16	ASH-05000-0160	DH7301M005560	GUIDE, TOP (R) US 5¢
6	ASH-05000-0089	DH7101M025523	SPRING, ACTUATOR		ASH-05000-0049	DH7301M025560	GUIDE, TOP (R) US 25¢
7		S3013RH99	SCREW, M3x13	17		DH7534M005605	RAIL, GUIDE (L) 2.5t
8	ASH-05000-0140	DH7534M025068	MICROSWITCH (D44L-R1LD)			DH7534M025605	RAIL, GUIDE (L) 2.0t
	ASH-05000-0039	DH7001P025013	PROXIMITY SENSOR			DH7534M025605	RAIL, GUIDE (L) 3.2t
9	ASH-05000-0086	N3000HX99	NUT, M3	18		DH7534M025607	COVER, GUIDE (R)
10		DH7301M025069	BRACKET, M/S MOUNTING (INBOARD)	19		S3010HXS	SCREW, M3x10 UPSET SF SS
11		S3016RH99	SCREW, M3x16	20	ASH-05000-0091	DH7101M025525	011 BALL BEARING
12		DH7534M005601	PLATE, BACK US 5¢	21	ASH-05000-0090	DH7101M025524	RETAINER, CHECK BALL
		DH7534M025601	PLATE, BACK US 25¢	22	ASH-05000-0092	DH7101M025527	BOLT, M4x10 WING
		DH7534M10T601	PLATE, BACK \$1T	23		S3012HXS	SCREW, M3x12 UPSET SF SS
13		DH7301M005507	GUIDE, TOP (L) US 5¢	24	ASH-05000-0079	DH7534M025565	SUPPORT, ESCALATOR
	ASH-05000-0047	DH7301M025507	GUIDE, TOP (L) US 25¢	25		DH7534M025602	RAIL SPACER
	ASH-05000-0052	DH7301M10T507	GUIDE, TOP (L) \$1T	26	ASH-05000-0048	DH7301M025514	COVER, TOP

### DH-750 Model 51 Hopper Assembly

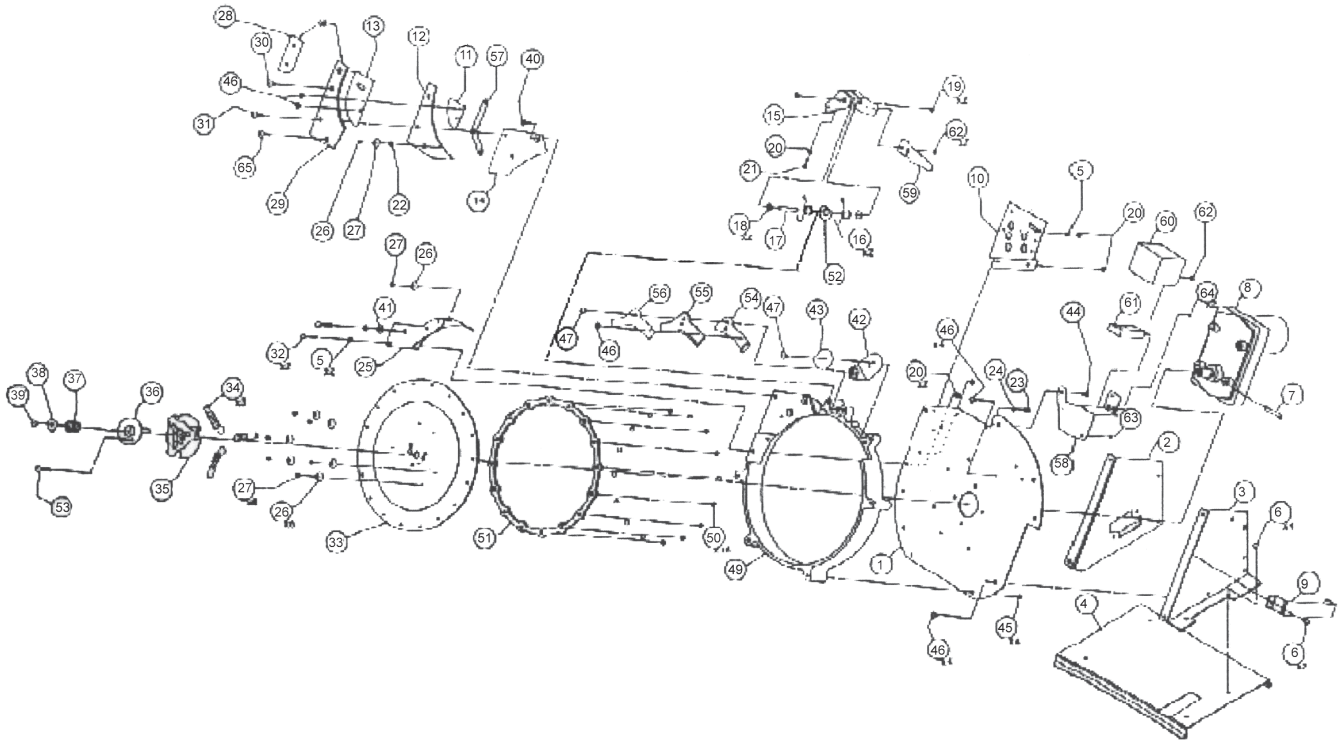

# Peripherals

## Hoppers (cont.)



**NOTE:** Items without a Bally part number are not stocked by Bally.

### DH-750 MODEL 51, BARTOP (AS-03107-SERIES)

Item#	Bally Part #	Asahi Seiko Part #	Description	Item#	Bally Part #	Asahi Seiko Part #	Description
1		DH7991M025001	PLATE, CHASSIS	34	ASH-05000-0013	DH7001M025034	SPRING, STIRRING
2		DH7534M025002	FRAME, SIDE (R)	35	ASH-05000-0014	DH7001M025035	COVER, SPRING
3		DH7514M025003	FRAME, SIDE (L)	36	ASH-05000-0015	DH7001M025036	HOLDER, SPRING
4		DH7534M025004	PLATE, BASE	37	ASH-05000-0016	DH7001M025037	SPRING, DISC
5		W4000SW99	WASHER, M4 SPLIT	38		W4015FW10	WASHER, 4x15x1.0 FLAT
6		S4006RHSW	SCREW, M4x6 W/SW	39	ASH-05000-0170	S4008LHSS	SCREW, M4x8 TRUSS HEAD SS
7	ASH-05000-0005	DH7001M025007	PIN, MOTOR DRIVE	40	ASH-05000-0108	S4015CS99	SCREW, M4x15 COUNTERSUNK
8	ASH-05000-0040	DH7004M025008	MOTOR, 24VDC (DME44S7C-272)	41		W4010FW10	WASHER, 4x10x1.0 FLAT (US 5¢ ONLY)
9		DH7001M025055	HANDLE	42	ASH-05000-0029	DH7001M025073	SEPARATOR, COIN
10	ASH-05000-0097	DH7101M025536	BRACKET, ESCALATOR MOUNTING	43	ASH-05000-0030	DH7001M025074	RETAINER, SEPARATOR
11	ASH-05000-0168	DH7101M005530	GUIDE, TRANSITION (R), US 5¢		ASH-05000-0037	DH7001M10T074	RETAINER, SEPARATOR, \$1 TOKEN
		DH7101M025530	GUIDE, TRANSITION (R), US 25¢	44		S4010HXSS	SCREW, M4x10 UPSET SF SS
	ASH-05000-0044	DH7101M10T530	GUIDE, TRANSITION (R), \$1 TOKEN	45		S4014HXSS	SCREW, M4x14 UPSET SF SS
12	ASH-05000-0169	DH7101M005531	GUIDE, TRANSITION (L), US 5¢	46		S3010HXSS	SCREW, M3x10 UPSET SF SS
		DH7101M025531	GUIDE, TRANSITION (L), US 25¢	47		S4012HXSS	SCREW, M4x12 UPSET SF SS
	ASH-05000-0045	DH7101M10T531	GUIDE, TRANSITION (L), \$1 TOKEN	48		S4008HXSW	SCREW, M4x8 UPSET SW SS
13	ASH-05000-0077	DH7534M025529	COVER, TRANSITION (R)	49	ASH-05000-0022	DH7001M025057	CAST FRAME
14	ASH-05000-0096	DH7101M025534	PLATE, COIN SLIDE	50		DH7001M025058	O6 BALL BEARING
		DH7514M025918	LEVER, ROLLER	51		DH7001M025059	RETAINER, BEARING
16	ASH-05000-0006	DH7001M025016	SPRING, ROLLER LEVER	52		DH7001M025064	WASHER, ROLLER LEVER
17	ASH-05000-0007	DH7001M025017	PIN, ROLLER LEVER	53		S4025LHSS	SCREW, M4x25 LARGE HEAD. SS
18	ASH-05000-0008	DH7001M025018	BEARING, ROLLER LEVER	54		DH7001M005070	PLATE, ADJUSTING, US 5¢
19	ASH-05000-0112	W3000ER99	O3 E-RING		ASH-05000-0026	DH7001M025070	PLATE, ADJUSTING, US 25¢
20		N4000HX99	NUT, M4			DH7001M10T070	PLATE, ADJUSTING, \$1 TOKEN
21		B4012HX99	BOLT, M4x12	55		DH7001M005071	RUBBER, JUMP, US 5¢
22	ASH-05000-0113	W3008FW08	WASHER, 3x8x0.8 FLAT		ASH-05000-0027	DH7001M025071	RUBBER, JUMP, US 25¢
23	ASH-05000-0106	S3010RH99	SCREW, M3x10		ASH-05000-0036	DH7001M10T071	RUBBER, JUMP, \$1 TOKEN
24	ASH-05000-0086	N3000HX99	NUT, M3	56	ASH-05000-0004	DH7001M005072	COVER, JUMP, US 5¢
25	ASH-05000-0002	DH7001M005025	KNIFE, US 5¢		ASH-05000-0028	DH7001M025072	COVER, JUMP
	ASH-05000-0009	DH7001M025025	KNIFE, US 25¢	57		DH7514M025650	SHIM, TRANSITION (L) O.3t
	ASH-05000-0034	DH7001M10T025	KNIFE, \$1 TOKEN			DH7514M10T650	SHIM, TRANSITION (L) 0.5t
26	ASH-05000-0010	DH7001M025026	BOSS, PLASTIC	58		DH7514M025915	BRACKET, OPTIC MOUNTING
27	ASH-05000-0011	DH7001M025027	SCREW, BEVEL-HEADED	59		DH7514M025916	FLAG, OPTIC
28		DH7101M10T538	COVER, TRANSITION (L) \$1T	60		DH7514M025917	COVER, OPTIC
29	ASH-05000-0099	DH7101M025538	COVER, TRANSITION (L)	61		DH7514M025920	OPTIC
30		S4012HXSS	SCREW, M4x12 UPSET SF SS	62		N3000LN99	NUT, M3 NYLON LOCK
31		S4025HXSS	SCREW, M4x25 UPSET SF SS	63		S3005RHSF	SCREW, M3x5 W/SW & FW
32	ASH-05000-0001	B4025HXSS	BOLT, M4x25, SS	64		S3595TP99	SCREW, M3.5x9.5 TAPPING
33	ASH-05000-0003	DH7001M005033	DISC, US 5¢	65		S4020HXSS	SCREW, M4x20 UPSET SF SS
	ASH-05000-0012	DH7001M025033	DISC, US 25¢				
	ASH-05000-0035	DH7001M10T033	DISC, \$1 TOKEN				

DH-750 Model 51, Bartop Bowl Assembly

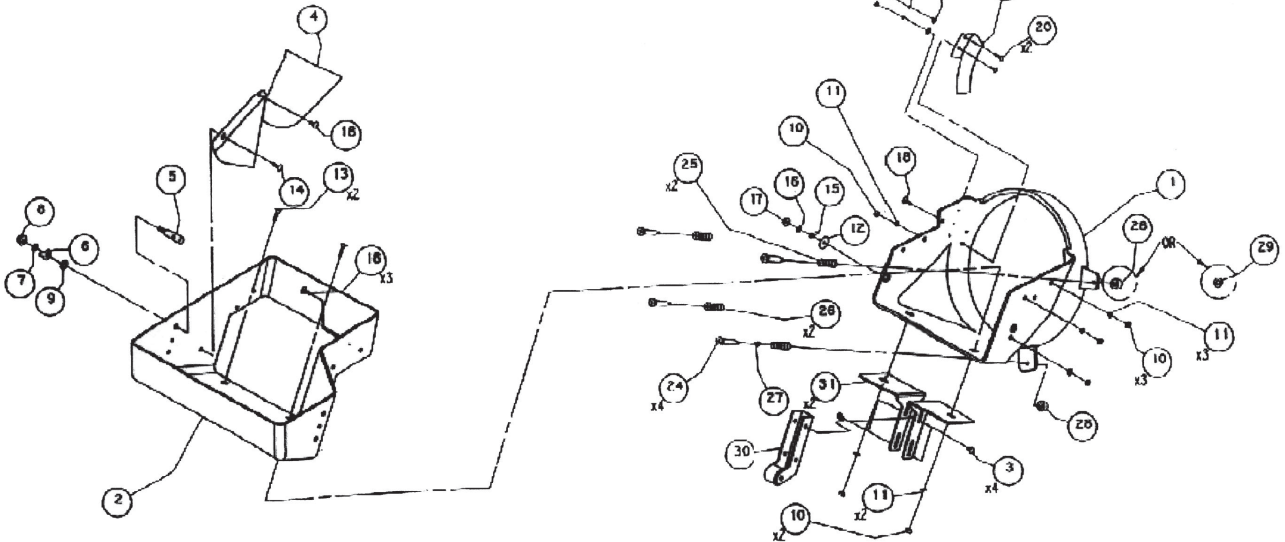

# Hoppers (cont.)



**NOTE:** Items without a Bally part number are not stocked by Bally.

### DH-750 MODEL 51, BARTOP BOWL ASSEMBLY

Item#	Bally Part #	Asahi Seiko Part #	Description	Item#	Bally Part #	Asahi Seiko Part #	Description
1		DH7031M025322	SCOOP, ALUMINUM	17		N4000SN99	NUT, M4 SHOULDER
2		DH7514M025050	BOWL, HOPPER	18		S4010LH99	SCREW, M4x10 LARGE HEAD
3		S4008RHSF	SCREW, M4x8 W/SW & FW	19	ASH-05000-0021	DH7001M025052	INSULATOR
4		DH7031M025046	PLATE, REGULATOR	20		S3010LH99	SCREW, M3x10 LARGE HEAD
5		DH7011M025153	PROBE PIN	21	ASH-05000-0113	W3008FW05	WASHER, 3x8x0.5 FLAT
6		DH7011M025093	05 WIRE TERMINAL	22		W3000SW99	WASHER, M3 SPLIT
7		W5000SR99	WASHER, M5 STAR	23	ASH-05000-0086	N3000HX99	NUT, M3
8		N5000SN99	NUT, M5 SHOULDER	24	ASH-05000-0018	DH7001M025047	SCREW, BOWL MOUNTING
9		W5012PW08	WASHER, 5x12x0.8 FLAT	25	ASH-05000-0019	DH7001M025048	SPRING, BOWL MOUNTING, UPPER
10		N4000HX99	NUT, M4	26	ASH-05000-0020	DH7001M025049	SPRING, BOWL MOUNTING, LOWER
11		W4000SW99	WASHER, M4 SPLIT	27	ASH-05000-0104	N4006HX99	NUT, M4 SMALL
12		W4015FW10	WASHER, 4x15x1.0 FLAT	28	ASH-05000-0038	DH7001M10T081	COLLAR, SPACING (\$1 TOKEN ONLY)
13	ASH-05000-0108	S4015CS99	SCREW, M4x15 COUNTERSUNK	29		W4010FW16	WASHER, 4x10x1.6 FLAT (5^ ONLY)
14	ASH-05000-0109	S4015LHSS	SCREW, M4x15 LARGE HEAD SS	30		DH7031M025324	ROLLER, SUPPORT
15		DH7011M025307	04 WIRE TERMINAL	31		DH7534M025325	BRACKET, BOWL SUPPORT
16		W4000SR99	WASHER, M4 STAR				

DH-750 Model 51, Bartop Escalator Assembly

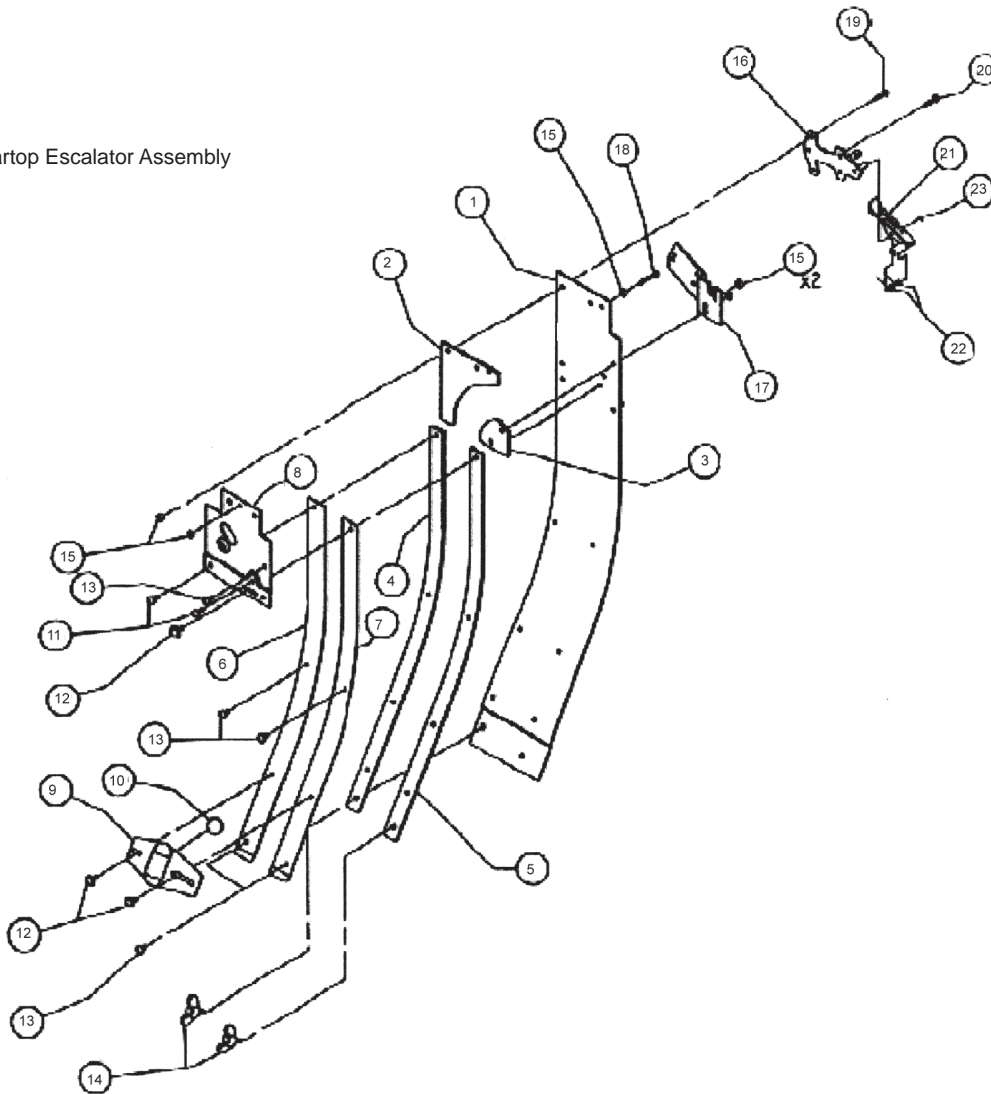

# Peripherals

## Hoppers (cont.)



**NOTE:** Items without a Bally part number are not stocked by Bally.

### DH-750 MODEL 51, BARTOP ESCALATOR ASSEMBLY

Item#	Bally Part #	Asahi Seiko Part #	Description	Item#	Bally Part #	Asahi Seiko Part #	Description
1		DH7514M005505	PLATE, BACK, US 5¢	8	ASH-05000-0048	DH7301M025514	COVER, TOP
		DH7514M025505	PLATE, BACK, US 25¢	9		DH7101M025524	BRACKET, BALL RETAINING
		DH7514M10T505	PLATE, BACK, \$1 TOKEN	10		DH7101M025525	011 BALL BEARING
2		DH7301M005507	GUIDE, 1 UP (L), US 5¢	11		S3012HXSS	SCREW, M3x12 UPSET SF SS
	ASH-05000-0047	DH7301M025507	GUIDE, TOP (L), US 25¢	12		S3012HXSS	SCREW, M3x12 UPSET SF SS
	ASH-05000-0052	DH7301M10T507	GUIDE, TOP (L), \$1 TOKEN	13		S3010HXSS	SCREW, M3x10 UPSET SF SS
3		DH7301M005560	GUIDE, TOP (R), US 5¢	14		DH7101M025527	BOLT, M4 WING
	ASH-05000-0049	DH7301M025560	GUIDE, TOP (R), US 25¢	15	ASH-05000-0086	N3000HX99	NUT, M3
4	ASH-05000-0146	DH7514M005506	RAIL, GUIDE (L), US 5¢	16		DH7101M025516	PLATE, ACTUATOR MOUNTING
	ASH-05000-0147	DH7514M025506	RAIL, GUIDE (L), US 25¢	17	ASH-05000-0025	DH7001M025069	PLATE, M/S MOUNTING, INBOARD
		DH7514M10T506	RAIL, GUIDE (L), \$1 TOKEN	18		S3016RH99	SCREW, M3x16
5	ASH-05000-0149	DH7514M005508	RAIL, GUIDE (R), US 5¢	19		S3010HXSW	SCREW, M3x10 UPSET SWSS
	ASH-05000-0150	DH7514M025508	RAIL, GUIDE (R), US 25¢	20		S3012HXSW	SCREW, M3x12 UPSET SW SS
	ASH-05000-0151	DH7514M10T508	RAIL, GUIDE (R), \$1 TOKEN	21		DH7301M025522	ACTUATOR, M/S, INBOARD
6	ASH-05000-0152	DH7514M025509	COVER, GUIDE (L)	22		DH7101M025523	SPRING, ACTUATOR
7	ASH-05000-0153	DH7514M025511	COVER, GUIDE (R)	23	ASH-05000-0111	W2000ER99	02 E-RING

HOPPER CAPACITIES					
PROBE AT LEVEL	STANDARD		SUPER		ASAHI-SEIKO
	VIDEO	SLOT	VIDEO	SLOT	
	5¢				
1	1100	700	2100	1200	
2	2100	1000	2900	2000	
3	3100	1700	3600	2500	
4		2200	4300	3400	
5		2800	5000	3800	5000
6		3400		4300	
PROBE AT LEVEL	STANDARD		SUPER		ASAHI-SEIKO
	VIDEO	SLOT	VIDEO	SLOT	
	25¢				
1	900	700	1600	1000	
2	1000	2200	1500		
3	1400	2800	2200		
4	1700	3400	3100		
5	2400	4000	3800	3500	
6	2900		4200		
PROBE AT LEVEL	STANDARD		SUPER		ASAHI-SEIKO
	VIDEO	SLOT	VIDEO	SLOT	
	\$1				
1	340	140	500	300	
2	560	280	640	460	
3	800	400	800	660	
4		560	900	800	
5		680	1100	1000	1200
6		820		1200	



## Ticket Printers

# ithaca™

TransAct Technologies, Inc. •  
20 Bomax Drive Ithaca, New  
York 14850 USA • Phone:  
Sales/Support 1-877-7ithaca

or (607)-257-8901 Fax: Sales (607) 257-3868 / Support  
(607) 257-3911 • <http://www.ithper.com>

### Ithaca Series 70 Impact Ticket Printer

The Series 70 takes the gamble out of consistent, quality impact printing for unattended printing applications. The Series 70 delivers receipts, tickets, and coupons at 4.9 lines per second with solid consistency. It features enhanced or emphasized font styles for greater legibility, and utilizes Oki® technology, known worldwide for quality, reliability, and snap-in/snap-out, user-friendly ribbon cassette. The Series 70 has a convenient "Paper Low" indicator to alert you before the paper roll runs out.



Series 70

#### Features

- All Printers are Mechanisms with Drive Electronics
- Print Speed: 4.9 lps.—On Standard Test Receipt
- One-Year Standard Warranty: Extended Maintenance Plan Available
- Data Buffer: 2K
- Auto-Cutter (Full Cut): 82.5 mm (3.25 in.)
- CPI: 5, 6, 8.5, 10, 12, 15, 17.1, 24
- Print Zone: 60 mm (2.34 in.)
- Self-Test: Test Ticket
- Low 37W Power
- Paper Low Indicator
- Character Sets: 2 ASCII (slashed ø and unslashed 0), IBM Character Sets I and II, French, French Canadian, Spanish, German
- Barcodes: Code 128, Interleaved 2 of 5, Interleaved 3 of 9

#### Power Requirements

- Standard (Internal Supply): 110/120 VAC, 60 Hz
- Optional (Internal Supply): 220/240 VAC, 50/60 Hz

#### Reliability

- Printer in full operation (using all available features)\*
- MTBF: 25,000 Hours
- Printhead: 200,000,000 Characters
- Auto-Cutter: 1,000,000 Cuts

*Reliability data is based on Ithaca standard test conditions.*

#### Environmental Specifications

- Operating Temperature: 0 to +50 degrees C (32 to +122 degrees F)
- Operating Humidity: 10 to 90% RH non-condensing

#### Media

- Standard Paper Roll—M75 (one-ply):  
Width: 82.5 mm (3.25 in.) Diameter: 89.0 mm (3.5 in.) or optional 152.0 mm (6 in.)  
One-ply Maximum Thickness: .11 mm (.0045 in.)  
Length Per Roll (3.5 in. dia.): 74.6 m (245 ft.)  
Length Per Roll (6 in. dia.): 148.8 m (488 ft.)
- Standard Paper Roll—M76 (two-ply):  
Width: 82.5 mm (3.25 in.) Diameter: 89.0 mm (3.5 in.) Maximum Thickness Per Ply: .09 mm (.0035 in.)  
Length Per Roll: 38.1 m (125 ft.)
- Ribbons: 3-4.5 Million Character Life  
Ithaca or Genuine Oki Snap-on Ribbon Cassette (Black or Purple)

#### Physical Characteristics

- Dimensions (without transport): 154 mm H x 274 mm L x 172 mm H (6.06 in. W x 10.75 in. L x 6.75 in. H)
- Weight: 3.86 kg (8.5 lbs.)



# Peripherals

## Ticket Printers (cont.)

### Connection Printer (Centronics)

1	BK/RD	Strobe	19		
2	BR	Data 1	20		
3	WT	Data 2	21		
4	OR/BL	Data 3	22		
5	YE	Data 4	23		
6	OR	Data 5	24		
7	GY	Data 6	25		
8	BL	Data 7	26		
9	YE/WT	Data 8	27		
10			28		
11	WT/BL	Busy	29		
12	WT/BR	Paper End	30		
13	WT/OR	Select	31	BR/BK	Printer Reset
14			32	WT/BK	Printer Fault
15			33	BK	Ground
16	BK	Ground	34		
17			35		
18			36		

### Backplane (Dual Row Header)

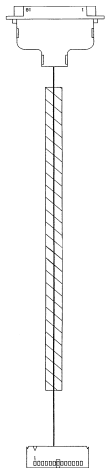

1	BR	Data 1	14		
2	WT/OR	Select	15	YE/WT	Data 8
3	WT	Data 2	16		
4	WT/BL	Busy	17	BK/RD	Strobe
5	OR/BL	Data 3	18		
6			19	BR/BK	Printer Reset
7	YE	Data 4	20		
8	BK-1	Ground	21	WT/BK	Printer Fault
9	OR	Data 5	22		
10	BK-2	Ground	23	WT/BR	Paper End
11	GY	Data 6	24		
12			25		
13	BL	Data 7	26		

Changing the Ribbon Cassette: Change the cassette when the print becomes faded. Worn ribbons can damage the print head.

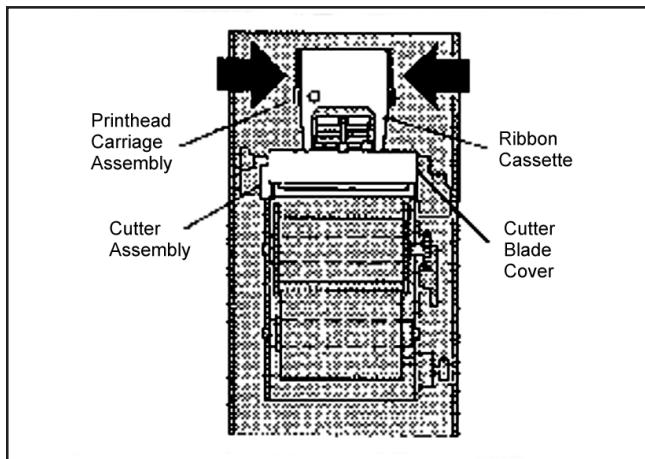

1. To remove the old cassette slide the Printhead Carriage Assembly to the middle.
2. Hold down the Cutter Blade Cover.
3. Grasp the bottom of the ribbon cassette and pull out.

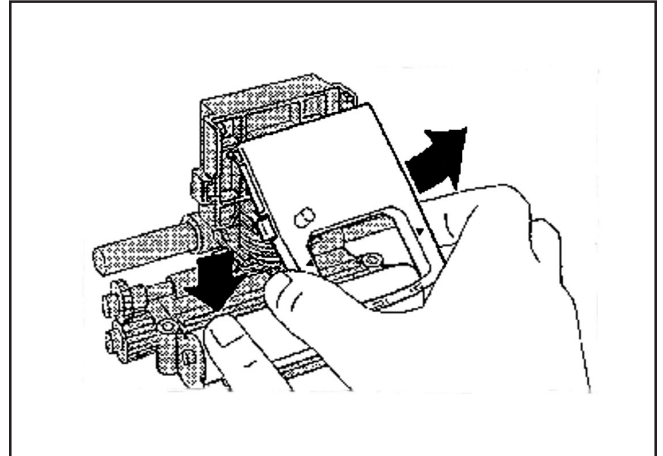

4. To install the new cassette hold down the Cutter Blade Cover.
5. Align the grooves at the top of the cassette with the tabs on the Printhead Carriage Assembly.
6. Pivot the ribbon cassette into the Printhead Carriage Assembly until it snaps into place.
7. Tighten the ribbon by turning the knob on the cassette clockwise.

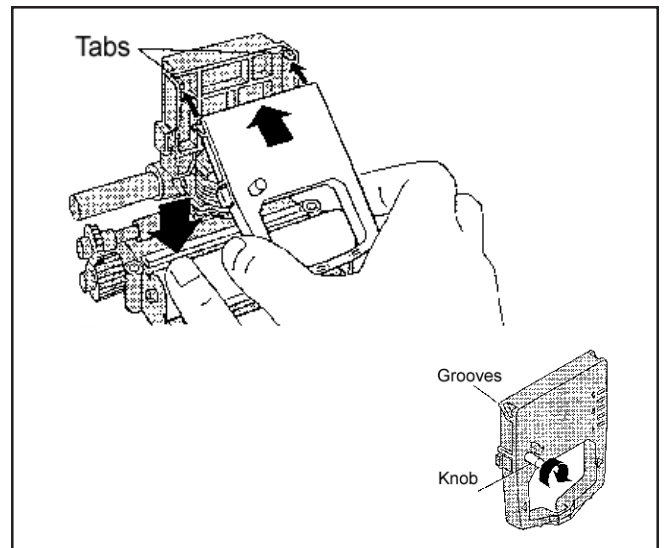

## Ticket Printers (cont.)

### Ordering Supplies

The following parts are available through TransAct Technologies, Inc.:

Description	Part #
Paper (two-ply)	98-0558
Ribbon Cassette (black or dark purple)	06-0560 (case of 12)
Supply Roll Spindle Large Diameter	09-1230
Supply Roll Spindle Small Diameter	09-1494
Take-up Spindle Take-up Core	06-0597
Take-up Flange	06-0599
Take-up Assembly (both core and flange)	06-0993
Power Cord	06-0561
Fuses 1.0 Amp, 125 Volt	150-9810010
1.5 Amp, 125 Volt	150-9810015
Printhead	06-0565
Printhead Clamp	06-0571

### Changing Paper

Change the Supply Roll paper when you see the pink stripe on the receipt paper or when the terminal indicates the paper is low. Although the pink stripe appears with eight to ten feet left on the roll, the printer will print only 21 inches after the Paper Low sensor activates.

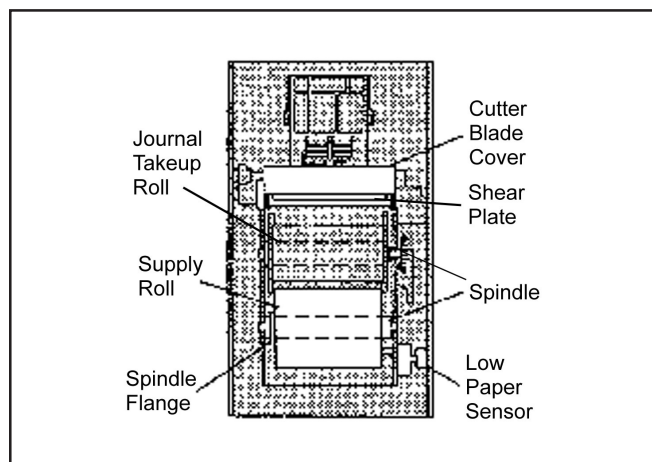

1. Unsnap the Journal Takeup Roll Spindle from the bracket. Tear off the yellow journal paper using the Shear Plate.

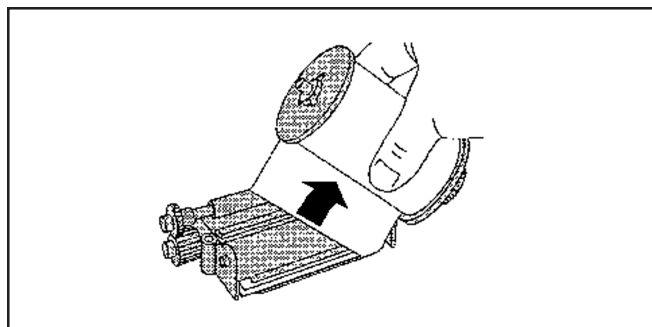

2. Remove the spindle from the journal by unscrewing the left flange in the direction of the OFF arrow. Secure and store the journal roll as required.

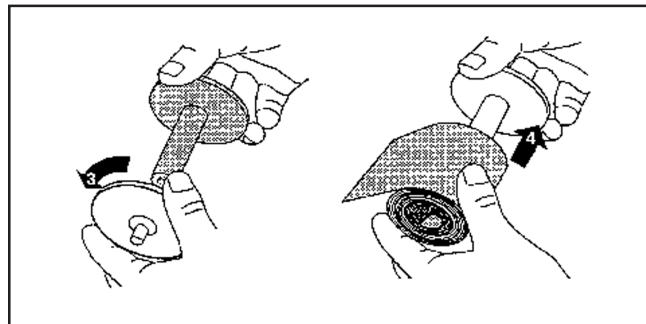

3. Unsnap the Supply Roll Spindle from the bracket. Hold down the Cutter Blade Cover and pull the remaining paper out of the printer.

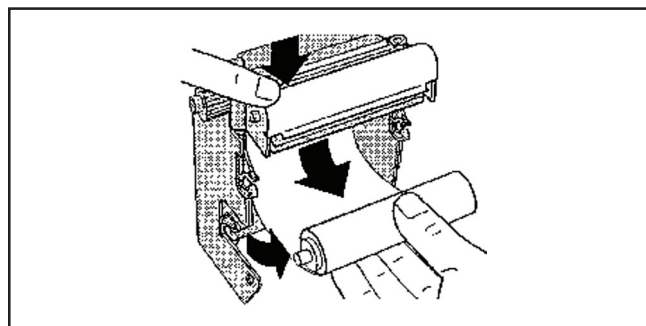

4. Remove the spindle from the used supply roll and set it aside. Don't throw it away.

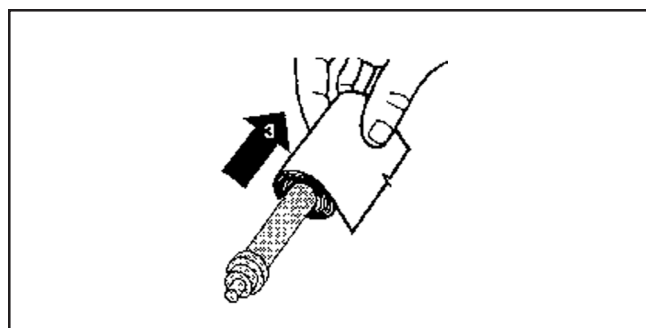

5. Trim enough of the new Supply Roll for a straight edge free from glue.
6. Put the spindle that was removed from the used supply roll into the new roll so that the white receipt paper is on the outside (See figure below). Snap the spindle into the lower set of snaps in the Bucket.
7. Hold down the Cutter Blade Cover and push the paper up through the throat in the back of the Bucket until the paper passes the printhead.

## Ticket Printers (cont.)

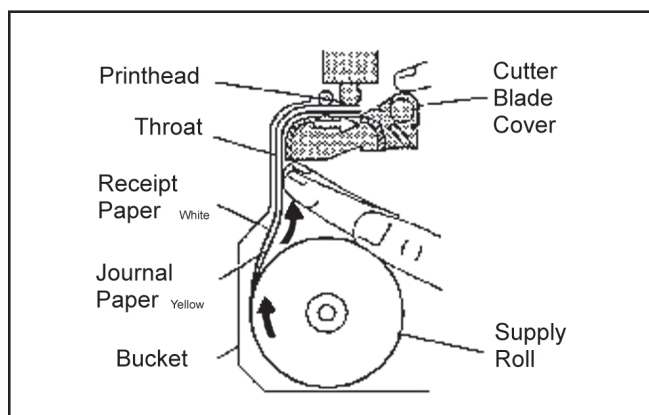

8. The receipt and journal thread through different paths. Using the Thumb Wheel ( Gear on the left side. See bottom figure) to advance the paper, guide the journal and receipt paper so that they are separated by the Shear Plate.

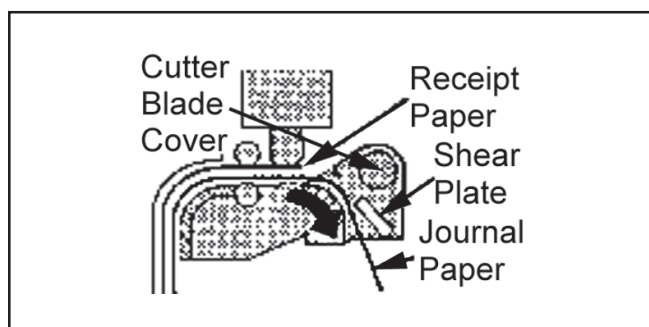

9. Advance about six inches of paper then tear off only the white receipt ply.

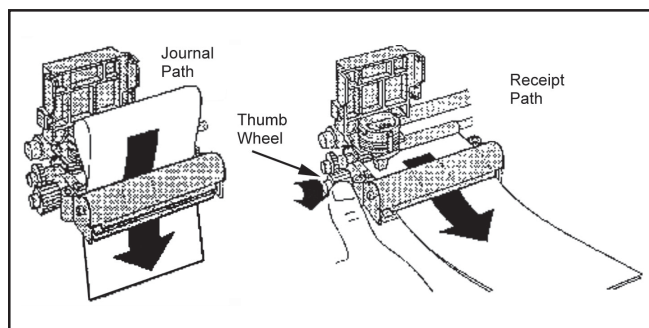

10. Reassemble the Journal Takeup Spindle by turning the flange in the direction of the ON arrow. Do not overtighten.
11. Fold about 1/2" of the journal paper and insert it into the groove of the Journal Takeup Spindle so that the gear is to the right.

12. Turn the Journal Takeup Spindle a few turns in the direction of the ON arrow to take up the excess journal paper.

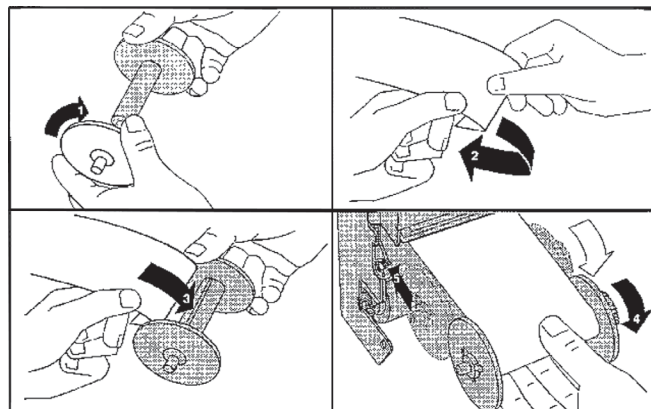

### Function Switch

The Function Switch is a momentary two-position switch that provides the following functions:

With power ON:

Left: Incremental paper advance  
Right: Auto paper advance and cut.

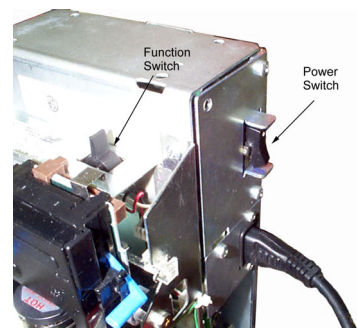

Position switch with power OFF, then power ON:

Left: Print Test  
Right: Hex Data Dump

### Replacing the Printhead



**WARNING:** The printhead may be hot.

1. Remove the ribbon cassette.
2. Release the printhead by unfastening the Printhead Clamp. Pull the tab on the left to swing it open.
3. Hold down the Cutter Blade Cover.
4. Pull the printhead free from the edge connector and carriage.
5. Using the guide on the printhead, slide the new printhead onto the carriage and into the edge connector.

## Ticket Printers (cont.)

6. Secure the printhead with the Printhead Clamp.
7. Put the ribbon cassette back in.

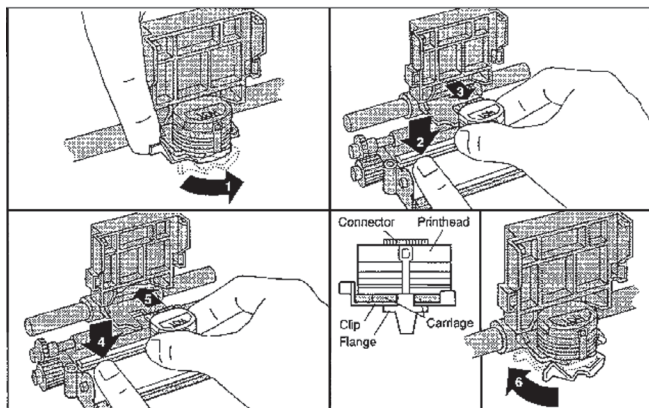

8. Check the print quality. Use the blue lever on the side of the carriage for lighter or darker printing.

## Ithaca Series 700 Thermal Ticket Printer



Series 700

Coin-free slot machines have never been so hassle-free. With the Series 700, the ticket will not stick out until it is completely printed. This prevents players from pulling it too soon—a major cause of printer problems. Another practical feature is a user-friendly, illuminated front bezel; a ticket supply box that holds 400 tickets; and a ball-bearing drawer chassis that slides out for easy ticket loading and maintenance.

### Features

- Print Resolution: 8 dots per mm (203dpi) Horizontal and Vertical
- Easy Ticket Loading
- Print Zone Width: 56 mm (2.205 in.)
- Data Buffer: 4K
- Memory: 64K EPROM & 32K RAM
- Self Diagnostics
- Standard Warranty: 1 year
- Bar Code: Code 3 of 9, Interleaved 2 of 5, UPC-A & UPC-E, Codabar,
- EAN8 and EAN13, Code 128, and Postnet
- Ticket Low Sensor
- Top of Form/Ticket-Out Sensor
- High Quality Printing: Text, Barcodes, Graphics, Lines Bitmap Graphics, Portrait, and Landscape Printing
- Ticket is contained within the printer until printing is complete, preventing user interference.

### Printing Characteristics

- Print Speed: 51 mm/sec (2 in. per second)
- Five Fonts: 7.5 cpi, 10 cpi, 12 cpi, 16.5 cpi, and 20 cpi
- Normal, Double-high, Double-wide, and Double-high/Double-wide print modes
- Prints on 62 mm x 120 mm, 65 mm x 120 mm, 65 mm x 156 mm (dollar-bill size) tickets

*NOTE: 65 mm x 156 mm ticket requires no printing on last 1.4 inches of each ticket*



# Peripherals

## Ticket Printers (cont.)

### Physical Characteristics

- 750—139 mm W x 85 mm H x 159 mm D (5.46 in. W x 3.36 in. H x 6.27 in. D)
- Overall Size with All Options (with 120 mm length ticket supply box):  
139 mm W x 85 mm H x 287 mm D (5.46 in. W x 3.36 in. H x 11.29 in. D)  
Weight: 3.31 kg (7.30 lbs.)
- Overall Size with All Options (with 156 mm length ticket supply box):  
139 mm W x 85 mm H x 325 mm D (5.46 in. W x 3.36 in. H x 12.8 in. D)  
Weight: 3.41 kg (7.50 lbs.)

### Media (Thermal Ticket, Fan Fold, Perforated)

- Type: Top coated, high sensitivity, direct thermal (Kanzaki TO-381N or approved equivalent)
- Thickness: 0.112 mm (0.0044 in.)
- Width x Length: 62 mm (2.44 in.) x 120 mm (4.73 in.); 65 mm (2.56 in.) x 120 mm (4.73 in.); 65 mm (2.56 in.) x 156 mm (6.14 in.) dollar-bill size
- Standard Store: 400 tickets per stack

### Interface

- Bi-Directional RS232C
- CTS and/or XON/XOFF Handshake

### Power Requirements

- 24VDC: 1.5A (supplied by system)
- Exit Lamp: 13VDC @ 150mA (supplied by system)

Reliability: Printhead Life: 25 km

### Environmental Specs

- Operating Temperature: 0C to + 40C
- Storage Temperature: -20C to + 70C
- Operating Humidity: 5 to 95% RH Non-Condensing

### Troubleshooting

If the 700 Series printer is experiencing printing problems, check to see if the unit is receiving power. The

green test LED, located on the top of the “Core” printer, should be on when the printer is correctly receiving power. After confirming that the printer is receiving power, check to see that the ticket has been loaded correctly and is not jammed in the ticket path. Pressing the Ticket Feed switch on the top of the “Core” printer will advance a single ticket through the print mechanism, automatically positioning the tickets correctly. Check all connections to ensure a proper signal.

If the printer does not stop feeding when it automatically scrolls the ticket, check to see that the tickets are facing the right direction so the ticket present sensor detects the Black Dot/Top of Form indicator.

**Loading Tickets into the Feeding Mechanism:** The first ticket of the stack must be inserted into the printer by hand. With the Series 700 Printer Ticket Supply Box, there is a guide to direct the ticket into the printer mechanism. To load the printer, grasp the first ticket, and insert it into the guide until the ticket reaches the printer mechanism. Continue pushing gently until the printer mechanism detects the ticket and the motor pulls it through the printer. The printer will stop feeding automatically. Pressing the Ticket Feed button on the printer controller board will run the motor to present blank tickets or to aid in loading.

1. Insert the first ticket, blank side up, into the ticket feed guides as shown by the load ticket arrow on the instruction card.
2. The printer will automatically feed the ticket when the ticket is sensed by the printer.
3. If ticket does not feed automatically, press the Ticket Feed switch.
4. Remove the excess ticket from the front of the printer.

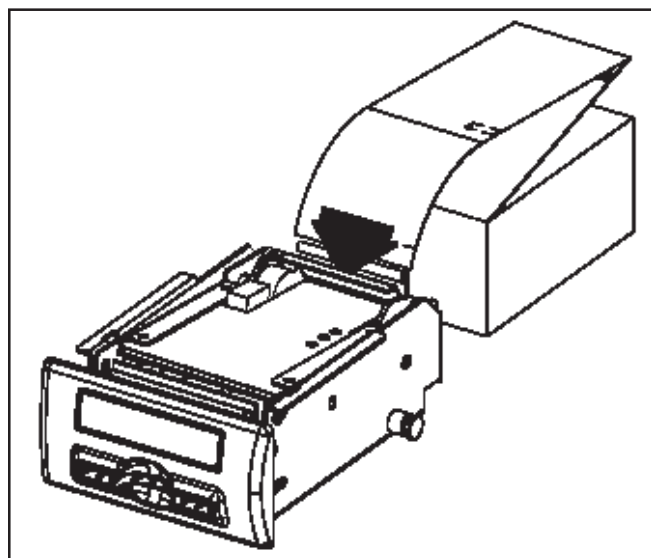



## Ticket Printers (cont.)

**SII** ● Seiko Instruments USA Inc. •  
Micro Printer Division • 2990  
West Lomita Blvd., Torrance, CA  
Selko Instruments Inc. 90505 • Phone: (800) 553-6570  
Fax: (310) 517-8154 • www.seikoprinters.com

### PSA-66 Thermal Ticket Printer



PSA-66-ST

**Operator Interface:** The printer has status indicators and two controls. The status indicators are part of the Keypad. They are LEDs labeled STATUS and ERROR. The Operator controls are the Keypad and the Platen Release Lever.

#### Loading Paper

To load paper, pull open the printer drawer until the paper tray is completely accessible. Place the paper stack in the printer as indicated by the band around the stack and the Paper Orientation Label in the paper tray. Present the paper to the Paperfeed slot.

The automatic loading feature of this system will advance at least one ticket through the printer. The Platen Release Lever and the paper advance button are provided as support, but usually are not required to load paper.



**NOTE:** The Keypad CUT function is inoperative.

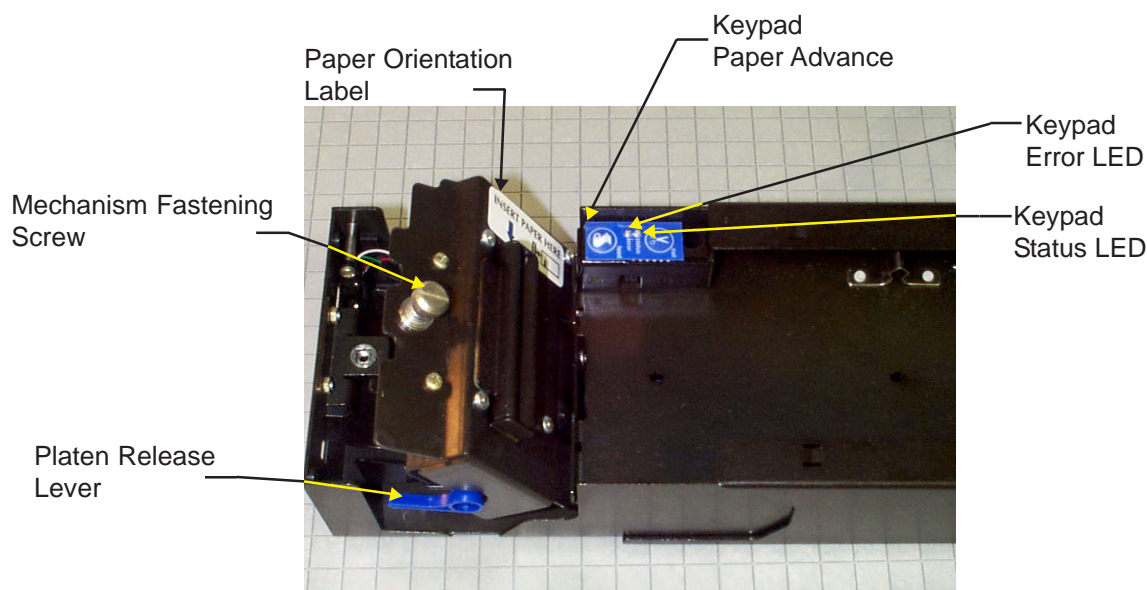
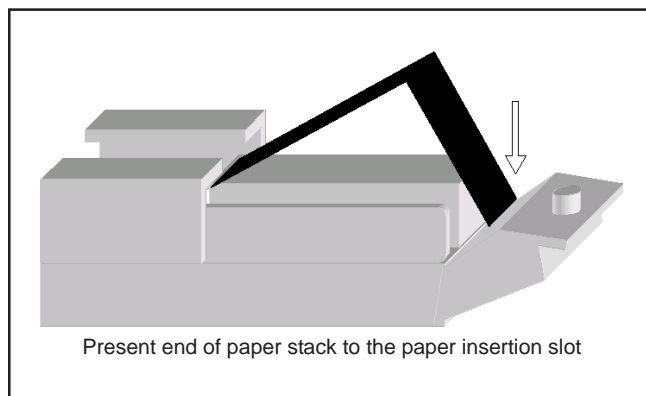
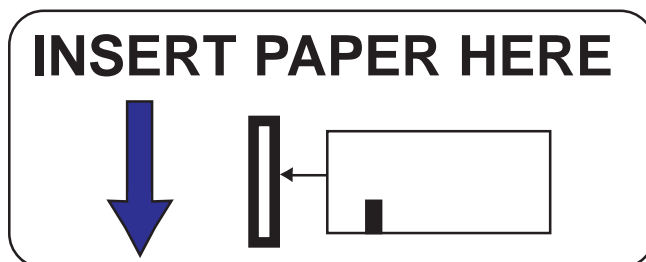
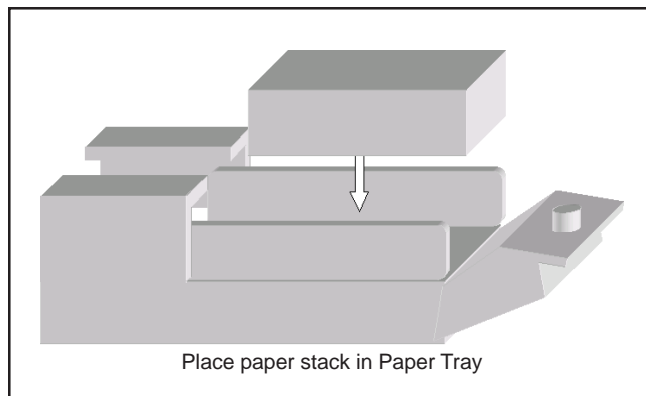

Component Identification

# Peripherals

## Ticket Printers (cont.)

### Keypad LED Operation

The following table lists the conditions reported by the keypad LEDs.

CONDITION	STATUS LED	EERR LED
Unit in Powered Off	OFF	OFF
Unit Ready	ON	OFF
Unit Flushed	ON	ON
Paper out	OFF	ON
Head Up	OFF	ON
Temperature Error	OFF	MED BLINK
Voltage Error	OFF	SLOW BLINK
Print Head Error	ON	FAST BLINK
Flash Memory Error	SLOW BLINK	MED BLINK
Buffer Overflow	OFF	FAST BLINK
Missing Black Index Mark	ON	FAST BLINK
Paper Jam	ON	FAST BLINK

### Error Conditions

**Paper Out:** The printer detects that paper is not present. The printer scans for a paper-out condition at all times. Remedy by loading a new paper stack.

**Head Up:** This condition results from lowering the Platen Release Lever. To remedy, raise the blue lever on the side of the unit.

**Temperature Error:** The printer has overheated. If the printer is operating environment is at room-temperature, this error would most likely be the result of a hardware problem. The printer will automatically resume operation when the head temperature cools within operational limits.

**Voltage Error:** The printer detected a power supply voltage (+24VDC to +25VDC) outside of legal limits. The printer will automatically resume operation when the power supply is within range.

**Print Head Error:** The printer senses an interfacing problem with the thermal print head. The error state remains until the power is cycled or the unit is reset. If the problem persists, the printer will require service.

**Flash Memory Error:** The printer is unable to program the Flash memory on the board. The printer will remain in error state until the power is cycled or the unit is reset. If the problem persists, the printer will require service before font or graphic data can be downloaded.

**Buffer Overflow:** A buffer overflow typically results from a mismatch in handshaking. The printer will remain in error state until the power is cycled or the unit is reset.

**Missing Index Mark:** While feeding paper or while printing, a black mark has not been seen within approximately 10" of paper. Remedy by using the correct paper in the printer, or installing the paper in the correct orientation. The condition is removed by raising the Platen Release Lever (presumably to change the paper).

**Paper Jam:** The printer detected an obstruction in the paper path. Remedy by opening the printer head and inspecting for a jammed ticket.

**Self Test:** If the Keypad FEED is held during power on or reset, a self test will be triggered. Proper operation will result in the printing of a configuration ticket.

<b>Model:</b>	<b>PSA-66-ST</b>
<b>Firmware:</b>	<b>1.0.0.0</b>
<b>COMMUNICATION</b>	
<b>Interface:</b>	<b>serial</b>
<b>Baud Rate:</b>	<b>19200</b>
<b>Data Bits:</b>	<b>8</b>
<b>Parity:</b>	<b>NONE</b>
<b>Handshaking:</b>	<b>HARDWARE</b>
<b>PRINT CONTROL</b>	
<b>Darkness Control:</b>	<b>+00%</b>
<b>Black Bar Index:</b>	<b>Disabled</b>
<b>Print On Demand:</b>	<b>Disabled</b>
<b>Auto Sleep Timer:</b>	<b>Off</b>
<b>SYSTEM RESOURCES</b>	
<b>FLASH -Used:</b>	<b>000000</b>
<b>-Free:</b>	<b>024064</b>
<b>LIBRARY INVENTORY</b>	
<b>Templates:</b>	
<b>Print Regions:</b>	
<b>Graphics:</b>	
<b>Fonts:</b>	<b>3(0), 7(0), 8(0), 5(0)</b>

Sample Self-Test Ticket

# Accounting System Interface

All Bally machines can interface accounting systems through a connection on the backplane board. Protocols supported are SDS® and SAS®.

## EVO® V8700

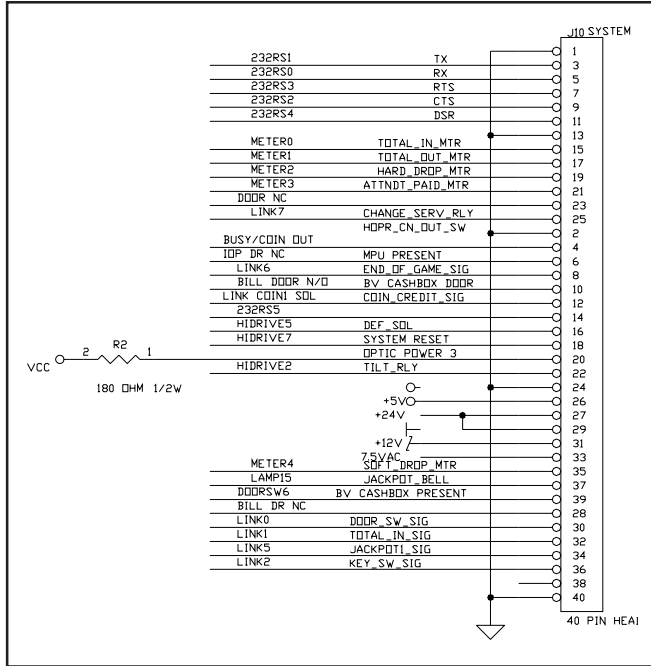

AS-03356-0501 Backplane Board

## Game Maker® V7000

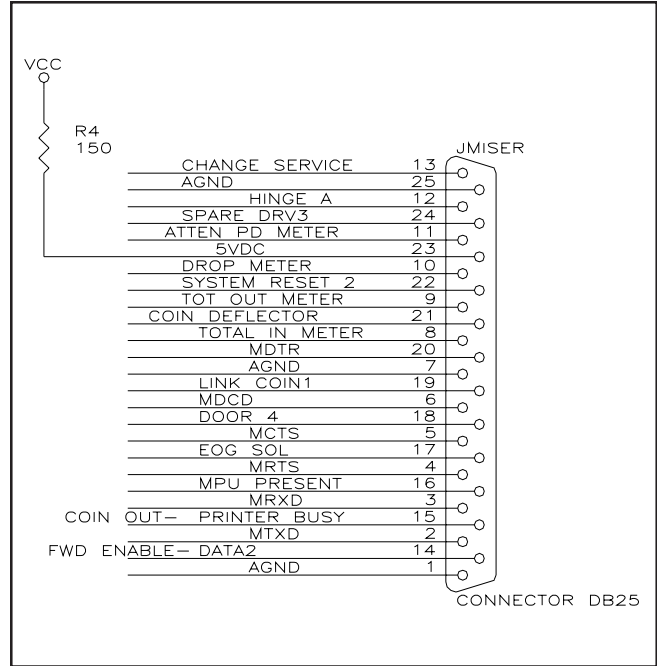

AS-03356-0247 Backplane Board

## Game Maker® V7200

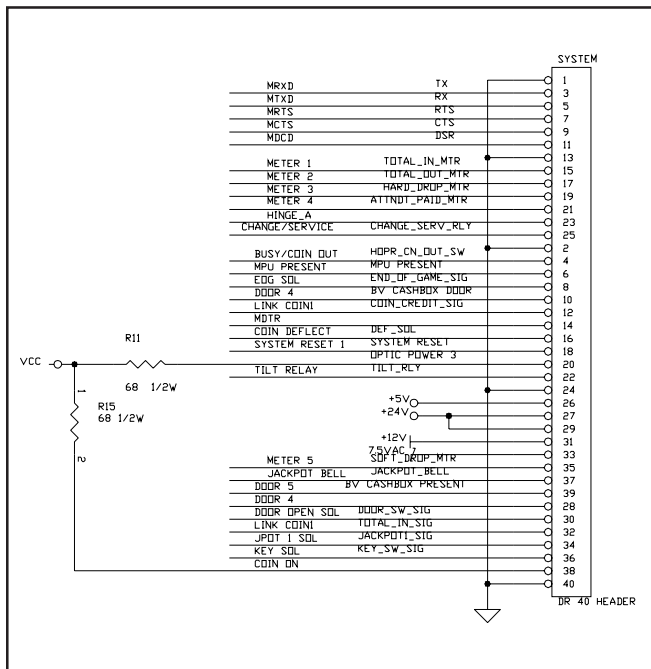

AS-03356-0432 Backplane Board

## ProSlot® 6000

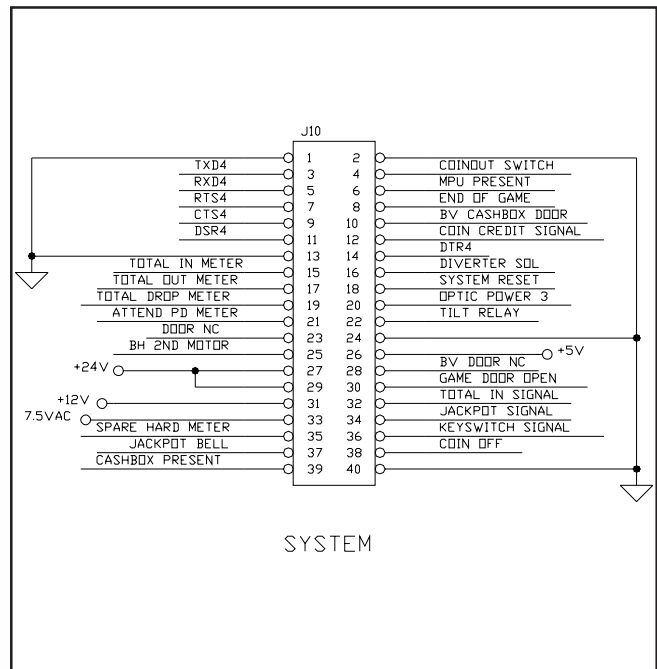

AS-03356-0445 Backplane Board

# Peripherals

## Accounting System Interface (cont.)

ProSlot® 5500

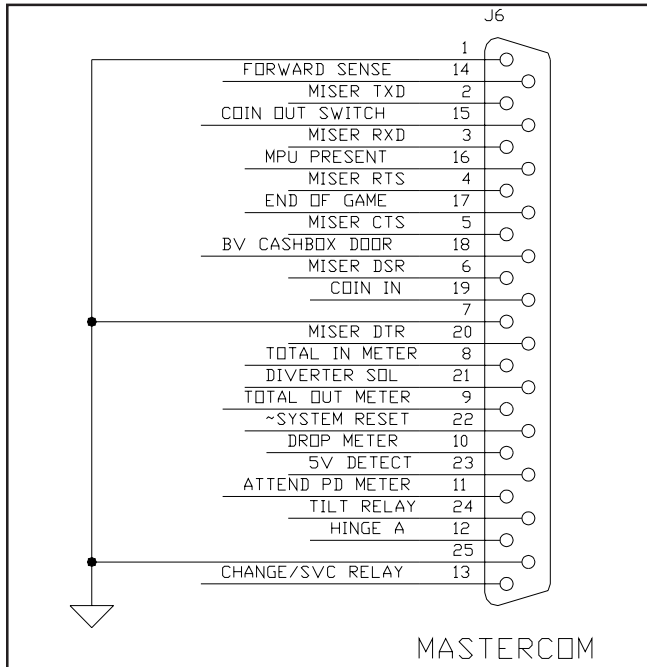

AS-03356-0207 Backplane board



**NOTE:** See Module MK10-SVMOD-0005, SDS Parts Reference for hardware requirements.

### CBL-20234-0001 System Interface Cable (ProSlot®)

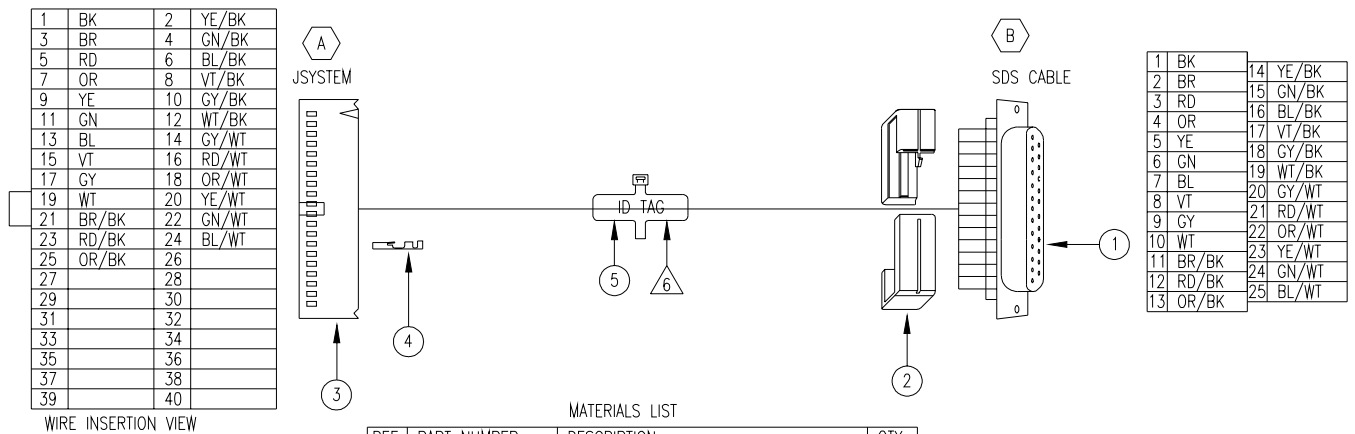

WIRE INSERTION VIEW

#### MATERIALS LIST

REF.	PART NUMBER	DESCRIPTION	QTY.
1	E-00910-0061	RECEPTACLE, DB25, SINGLE WIRE I.D.C	1
2	E-00910-0065	COVER, PLASTIC, DB25	1
3	E-01011-0140	CONN, HOUSING, DUAL ROW, 40 PIN	1
4	E-00671-0003	TERMINAL, MOD IV, 24-20 AWG	25
5	E-00647-0020	MARKER TIE	1
6	E-00647-0004	CABLE TIE, 3/32" X 3 7/8"	-

## Accounting System Interface (cont.)

CBL-20238-0001 System Interface Cable (EVO®)

1	BK	2	YE/BK
3	RD	4	GN/BK
5	BR	6	BL/BK
7	OR	8	VT/BK
9	YE	10	GY/BK
11	GN	12	WT/BK
13	BL	14	GY/WT
15	VT	16	RD/WT
17	GY	18	OR/WT
19	WT	20	YE/WT
21	BR/BK	22	GN/WT
23	RD/BK	24	BL/WT
25	OR/BK	26	
27		28	
29		30	
31		32	
33		34	
35		36	
37		38	
39		40	

WIRE INSERTION VIEW

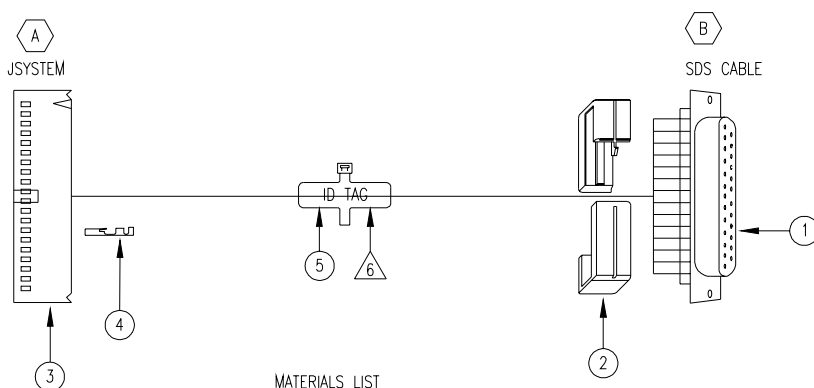

1	BK	14	YE/BK
2	BR	15	GN/BK
3	RD	16	BL/BK
4	OR	17	VT/BK
5	YE	18	GY/BK
6	GN	19	WT/BK
7	BL	20	GY/WT
8	VT	21	RD/WT
9	GY	22	OR/WT
10	WT	23	YE/WT
11	BR/BK	24	GN/WT
12	RD/BK	25	BL/WT
13	OR/BK		

### MATERIALS LIST

REF.	PART NUMBER	DESCRIPTION	QTY.
1	E-00910-0061	RECEPTACLE, DB25, SINGLE WIRE I.D.C	1
2	E-00910-0065	COVER, PLASTIC, DB25	1
3	E-01011-0140	CONN, HOUSING, DUAL ROW, 40 PIN	1
4	E-00671-0003	TERMINAL, MOD IV, 24-20 AWG	25
5	E-00647-0020	MARKER TIE	1
6	E-00647-0004	CABLE TIE, 3/32" X 3 7/8"	-



# Peripherals

## Accounting System Settings

Manufacturer	System Type	System Version	Machine Setting(s)		System Protocol and Settings
			Video	Slot	
Acres Gaming	Acres SAS@ 5.01	SAS@ - 5 EFT Optional* Bonusing Optional*	Terminal ID: VGD > set to 1 Host Type > set to Acres (bonusing would be set in this mode if desired) Printer: Validation > set to Enhanced	Switch bank DS1 > #s 1 and 5 off for EFT Enable Switch bank DS1 > #s 1, 2, and 5 off for EFT Disable Switch bank DS1 > #3 off for Bonusing Option 78Ho set to 1 Printer: Option 73 set to 2	SAS@ Protocol
Casino Data Systems	CDS SAS@ 3.62 - 3.64	SAS@ - 3 No EFT No Bonusing	May be set to Popeye 5.01 Terminal ID: VGD > set to 1 Host Type > set to Standard or CDS Printer Validation > set to Standard	Switch bank DS1 > #s 1 and 2 off for EFT Disable Option 78Ho set to 1 Printer: Option 73 set to 2	SAS@ Protocol: set to IGT Winner (for SAS@ 5 EVO@s, old Game Maker@ cable [with single wire pigtail] must be used)
	CDS SAS@ (Windows NT [Oasis])	SAS@ - 4 / 5 No EFT No Bonusing	Terminal ID: VGD > set to 1 Host Type > set to Standard Printer Validation > set to Standard	Switch bank DS1 > #s 1, 2 and 5 off for EFT Disable Option 78Ho set to 1 Printer: Option 73 set to 1	SAS@ Protocol: set to IGT Winner System cable #20115 for SAS@ communication with printers
Gaming System International	GSi SAS@ 5.01	SAS@ - 5 No EFT No Bonusing	Terminal ID: VGD > set to 1 Host Type > set to Standard Printer Validation > set to Standard	Switch bank DS1 > #s 1, 2 and 5 off for EFT Disable Option 78Ho > set to 1 Printer: Option 73 set to 1	SAS@ Protocol: BIN > #74 Flash > F9 System Driver > 4
Konami Gaming	Paradigm SAS@ 5.01	SAS@ - 5 No EFT No Bonusing	Terminal ID: VGD > set to 1 Host Type > set to Standard Printer Validation > set to Standard	Switch bank DS1 > #s 1, 2 and 5 off for EFT Disable Option 78Ho > set to 1 Printer: Option 73 set to 1	SAS@ Protocol
Bally Systems	SDS@	Standard	Standard settings EVO@ (i.e. Popeye) > set to SAS@ 5.01	Switch bank DS1 > set all to ON Printer > Option 73 set to 3	SAS@ Protocol Must have MC250 board with R-5 EPROM
ACSC Gaming Systems (Alliance Gaming Corporaton)	SAS@ 5.01	SAS@ - 5 EFT	Terminal ID: VGD > set to 1 Host Type > set to Standard Printer Validation > set to Standard	Switch bank DS1 > #s 1 and 5 off for EFT Enable Option 78Ho > set to 1 Printer: Option 73 set to 1	SAS@ Protocol
IGT Gaming	EDT SAS@ 2.4	SAS@ - 1 No EFT	Use standard SDS settings	Switch bank DS1 > set all to ON Option 78Ho > set to 1	SAS@ Protocol (EVO@ and S6000 must use IGT cable #607-645-00 or to talk 5.01 SAS@)
	EDT SAS@ 2.62 - 3.6	SAS@ - 2 / 3 No EFT	Terminal ID: VGD > set to 1 Host Type > set to Standard	Switch bank DS1 > #1 to OFF Option 78Ho > set to 1 (try SAS@ - 1 settings first)	SAS@ Protocol (EVO@ must use IGT cable #607-645-00)
	IGS SAS@ 5.01	SAS - 5 No EFT	SAS@ > set to 5.01 Terminal ID: VGD > set to 1 Host Type > set to Standard Printer Validation > set to Standard	Switch bank DS1 > #s 1, 2 and 5 off for EFT Disable Option 78Ho > set to 1 Printer: Option 73 set to 1	SAS@ Protocol Flash: "G"
	SAS@ 2.84 Easy Route	SAS@ - 2 / 3 No EFT	SAS@ > set to 2.84 Terminal ID: VGD > set to House Number Host Type > set to Standard Remote Reset > set to Enabled	Switch bank DS1 > #s 1 - 8 set to ON Option 78Ho > set to House Number Option 90 > set to 1 for Remote Reset	SAS@ Protocol

