



Glass and Decals

MODULE 3A

MK3A-SVMOD-9900
GLASS AND DECALS



**For Customer Service and information:
+1-702-896-7772 Outside the U.S.
1-877-GO-BALLY (877) 462-2559 in the U.S. and Canada
896-7772 in Las Vegas
FAX: +1-702-896-7710
or visit our website at <http://www.ballygaming.com>**

Glass and Decals

Module 3A

Table of Contents

Overview	3A-5
Video and Reel Machine Examples with Glass and Decal Descriptions	3A-6
Machine Model Glass Prefix Index - Slots	3A-7
Machine Model Glass Prefix Index - Video	3A-8
Decal Prefix Index by Machine Model - Slots	3A-9
Decal Prefix Index by Machine Mode - Video	3A-10
Decal Prefix Description and Sample Table	3A-11
Decal Examples	3A-12
Bill Validator Bezel Decal - D150 Series	3A-12
Bill Validator for V7000 (D157), V8000 (D159), and V7200 (D161)	3A-13
Hotdog Lockup for reels (D315), Play Coin Decal (D310 & D305), D170 & D158 Lockup Decals, and the D100 Denomination Decal	3A-14
D180 - Lockup for the V5500, D300 - Bill Validator for the Bartop	3A-15
Package Game Examples: D201, D201-00001-COIN, D201-xxxxx-BELY, and Top Award Insert - D400 "I" Size	3A-16
Decals - Actual Sizes - Black and White Outlines	3A-17
Bill Validator D157 for the V7000 with D100-xxxxx-BERM and D156 Inserts	3A-17
Bill Validator D159 for the V8000 with D156 Insert	3A-18
Bill Validator D161 for the V7200 with D170, D100-xxxxx-BERM and D156 inserts	3A-19
Bill Validator D180 for the V5500 with D190, and D100-xxxxx-5500 inserts	3A-20
Bill Validator D300 for the Bartop V7000; D315 Hotdog for Reels, Lockup text	3A-21
Bill Validator Bezel Decals: D150 Series	3A-22
Decal Inserts - D170 Lockup Text; D100-xxxxx-BERM Denomination and Package Game Decals: D201	3A-23
Decal Inserts - Coin Play Decals: D305, and D310 for Slant and Upright; D100-xxxxx-5500 and D190 for V5500; the D156 Bill Validator Bill Value Decal	3A-24
Top Award / Feature Glass Decal D400 Series Standard Window Openings	3A-25
Machine Model Numbering Convention	3A-27
Top Boxes	3A-30
Top Boxes for Slant Machines	3A-30
Top Boxes for Upright Reel Machines	3A-31
Glass Examples	3A-32



Table of Contents (continued)

Slot Machine Images with Glass and Decal Prefixes	3A-35
ProSlot® 5500 Upright Casino Top (WT Cabinet) - Bill Validator Configuration	3A-35
ProSlot® 6000 Upright Casino Top (WT Cabinet) - Bill Validator Configuration	3A-36
ProSlot® 6000 Upright Round Top (WR Cabinet) - Cash Cage™ Configuration	3A-37
ProSlant® 5500/6000 Round Top (D6 Cabinet)	3A-38
Bell Ringer® - S5500/S6000 Slant with Bell Feature Top	3A-39
Roll the Dice® - S5500/S6000 Slant with Dice Feature Top	3A-40
Betty Boop™ - S6000 Slant with High Profile Feature Top	3A-41
Video Machine Images - with Glass and Decal Prefixes	3A-42
Game Maker® 7000 Bartop	3A-42
Game Maker® 7000 Upright - 14" Monitor and Package Game Configuration	3A-43
Game Maker® 7200 Upright with 14" Monitor - Standard Bill Validator and Cash Cage™ Formats	3A-44
Game Maker® 7200/7000 Slant - Standard Top Box	3A-45
Game Maker® 7000 - 20" Monitor	3A-46
Game Maker® 7000 with 20" Monitor and Top Box	3A-47
Game Magic® 8000	3A-48
Let's Make a Deal™ - V8000 with Top Box	3A-49
Slot Machine Express Model Theme and Art Form	3A-50

Glass and Decals

Module 3A

Glass and Decals

This module identifies the name and part number prefix of each glass piece and decal used on each machine. The Overview section shows examples of a reel and a video machine with the glass pieces named and decal inserts labeled with the part number prefix and the decal series named. This section also includes the Glass and Decal Index Tables that list the part number prefixes for each machine model supported by Bally Gaming. The Decal Prefix Description table lists the decal prefix series and illustrates the series with an example part number and description. **Note: A “D” in the part number prefix indicates a decal, a “G” in the part number prefix indicates a glass piece.**

The Decal Example section shows scaled images of most available decals. Most decals are the same size and shape as the example decal, and have the dimensions shown in the Decal Sizes - Black and White Outline section, however, some decals may differ from the example decals shown in these sections. This depends on the decal series. The Decal Example and Decal Sizes sections have been included for reference in identifying replacement decals. Refer to the Machine Image section for model-specific decal locations. If there is a question about the use of a decal on a particular machine that is not evident in the Machine Image section, please refer to the Decal Index Tables in the Overview section.

The Machine Model Numbering Convention section has been included to help clarify model-specific glass and decal information listed in the tables and on the identification plate on the side of the machine. The Top Box section shows the available top boxes for Bally machines. NOTE: Top box height is “extended” 2.5-3.25 inches if the top box includes the Player Tracking panel (bracket, keypad, display, and cardreader). Measurements shown in the Top Box section are not exact but are intended to provide the necessary information to distinguish between models.

The reel glass examples are included to show the relative differences in length and decal configuration of common reel glass that may not be evident in the Machine Image section. A standard top box/feature glass, and a top box/feature glass and a belly glass with decals configured for a package game, have been included to show different decal options.

The Machine Images section shows the most common decal configuration for each model, and shows alternate configurations as a pull-out image where applicable. The pointer labels include the part number prefix for the glass or decal, as well as the part description.

The Express Model Theme and Art Table are included to facilitate replacement part ordering.

If you have questions about a decal, piece of glass, or its part number, please contact your Bally Customer Service representative (contact information listed in the inside front cover and last page of this document.)

Video and Reel Machine Examples with Glass and Decal Descriptions

ProSlot® 6000 - Bullnose Cabinet (W6)

Game Maker® V7200

Glass

Top Box / Feature Glass

Video Monitor

Display/ Belly Glass



Decals

Bill Validator Decal - Prefix varies by validator. These decals have inserts. Exception: **Cash Cage™** decals are D150 series.

Coin Play Decal (D310 or D305) In some configurations, the **D170 Lockup Text Decal** is placed here.

Bill Validator Bezel Decal: D150 - Size and shape varies by Validator

Display/ Belly Glass

©1999 King Features Syndicate, Inc./Fleischer Studios, Inc.
™The Hearst Corporation/
Fleischer Studios, Inc.

Glass

Top Box / Feature Glass

Reel Glass



Progressive Meter Display (Available in some progressive machines.)

Decals

Top Award: D400 (If not a progressive award) There can be up to 4 "Top Award" Decal inserts.

Player Tracking system**. Usually consists of cardreader, keypad, and display (with **Overlay decal: D200** if custom, or M-R0617).

Lockup Decal - Hotdog (D315 - for Reels only)

Coin Play Decal D310 or D305

Bill Validator Bill Value Range Decal insert - (D156): shows bill denominations accepted by BV.

Bill Validator Decal - Prefix varies by validator. These decals have inserts. Exception: **Cash Cage™** decals are D150 series.

Bill Validator Bezel Decal: D150 - Size and shape varies by Validator

Denomination Decal: D100

Lockup text is sometimes included on-screen for video machines, as are coin denomination and pay table (top award) information.
**Player Tracking systems are also available for video machines.

Glass and Decals

**Machine
Model
Glass Prefix
Index -
Slots**

CABINET	DESCRIPTOR - Machine Model # (Position 6 & 7 - Reel Slots)	Feature / Top Box Glass	Midpanel Glass	S5500 Reel Glass W/O Bill Validator / S6000 Reel Glass W/ WBA Bill Validator	Reel Glass W/ Bill Validator	S6000 Reel Glass W/ Cash Cage	Display / Belly Glass
S5000/S5500 Narrow Chop Top	V	G603		G608	G607		G602
S5000/S5500 Narrow Casino Style	X	G604		G608	G607		G602
ProSlot® 5500 Chop Top (CT)	C6	G600		G593	G594		G595
ProSlot® 5500 Casino Top (WT)	W6	G592		G593	G594		G595
ProSlot® 5500 Round Top (WR)	R6	G609		G593	G594		G595
ProSlant® 5500 Round Top	D0	G679			G606		
ProSlant® 5500	B0	G605			G606		
ProSlot® 6000 Chop Top (CT)	C6	G600		G593		G705	G595
ProSlot® 6000 Casino Top (WT) & Bullnose	W6	G592		G593		G705	G595
ProSlot® 6000 Round Top (WR)	R6	G609		G593		G705	G595
ProSlant® 6000 Round Top	D6	G679			G606	G606	
ProSlant® 6000	B6	G605			G606	G606	
ProSlant® 6000 Without Top	OO				G606	G606	
Bell Ringer® S5500/S6000 Slant with Bell Feature Top	S64U3R0	G706 ^{##}	G707		G606	G606	
Roll the Dice® S5500/S6000 Slant with Dice Feature Top	S64U3C0	G684	G704 ^{**}		G606	G606	
Betty Boop™ S6000 Slant with High Profile Feature Top	M6	G689	G704 ^{**}		G606	G606	
^{**} This glass is located in the sound panel. ^{##} This is the bell tower glass Shaded areas indicate machines that are no longer produced.							



**Machine
Model Glass
Prefix Index
- Video**

CABINET	DESCRIPTOR - Machine Model Number	Feature / Top Box Glass	Midpanel Glass	Display / Belly Glass
V5500 Video Poker	VPOK09xxx	G580	G590 [#]	G583
V5500 Plus Video Poker Slant	VPOK0Sxxx			
V5500 Plus Video Poker	VPOK0Pxxx	G588		G591
Game Maker [®] V7000 Round Top*	VMPL0Rxxx	G674		G595
Game Maker [®] V7000 Chop Top*	VMPL0Cxxx	G678		G595
Game Maker [®] V7000 Casino*	VMPL0Wxxx	G676		G595
Game Maker [®] V7000 Slant Round Top	VMPL0Dxxx	G679		
Game Maker [®] V7000 14"	VMPL0Nxxx	G588		G591
Game Maker [®] V7000 20"	VMPL0Qxxx	G612		G583
Game Maker [®] V7000 Bartop	VMPL0Fxxx			
Game Maker [®] V7000 Slant (France)	VMPL0Sxxx	G605/G679	G708 [#]	
Game Maker [®] V7000/V7200 Slant	VMPL0Sxxx	G605		
Game Maker [®] V7000/V7200 Slant Without Top	VMPL00xxx			
Game Maker [®] V7000 20" Monitor and Top Box	VMPL4Wxxx	G592	G612	G583
Game Maker [®] V7200	VMPL0Nxxx	G701		G702
Game Magic [®] V8000	VMPL8Mxxx			G595
Game Magic [®] V8000 Round Top	VMPL9Rxxx	G710		G595
Let's Make a Deal™ V8000 With Top Box	VMPL8Lxxx	G592		G595

* Indicates a video game in a slot cabinet.

This glass covers the monitor.

Shaded areas indicate games that are no longer produced.

Glass and Decals

Decal Prefix Index by Machine Model - Slots

CABINET	Denomination Decal**	Bill Validator Bezel Decal	Bill Validator Decal*	Lockup Text Decal	Coin Play Decal	Top Award***	Player Tracking Bracket Overlay	Standard Bill Validator	Additional Info.
S5000/S5500 Narrow Chop Top	D100-BERM	D150		D315		D400	M-R0617 or D200 - Custom	None	
S5000/S5500 Narrow Casino Style	D100-BERM	D150		D315		D400	M-R0617 or D200 - Custom	None	
ProSlot® 5500 Chop Top (CT)	D100-BERM	D150		D315	D310 / D305	D400	M-R0617 or D200 - Custom	DBV	If G593, use D310 & D156 If G594, use D305
ProSlot® 5500 Casino Top (WT)	D100-BERM	D150		D315	D310 / D305	D400	M-R0617 or D200 - Custom	DBV	If G593, use D310 & D156 If G594, use D305
ProSlot® 5500 Round Top (WR)	D100-BERM	D150		D315	D310 / D305	D400	M-R0617 or D200 - Custom	DBV	If G593, use D310 & D156 If G594, use D305
ProSlant® 5500 Round Top	D100-BERM	D150		D315	D310	D400	M-R0617 or D200 - Custom	DBV	
ProSlant® 5500	D100-BERM	D150		D315	D310	D400	M-R0617 or D200 - Custom	DBV	
ProSlot® 6000 Chop Top (CT)	D100-BERM	D150	D156*	D315	D310 / D305	D400	M-R0617 or D200 - Custom	WBA	*If G593, use D310 & D156 If G705, use D305
ProSlot® 6000 Casino Top (WT) & Bullnose	D100-BERM	D150	D156*	D315	D310 / D305	D400	M-R0617 or D200 - Custom	WBA	*If G593, use D310 & D156 If G705, use D305
ProSlot® 6000 Round Top (WR)	D100-BERM	D150	D156*	D315	D310 / D305	D400	M-R0617 or D200 - Custom	WBA	*If G593, use D310 & D156 If G705, use D305
ProSlant® 6000 Round Top	D100-BERM	D150	D156*	D315	D310	D400	M-R0617 or D200 - Custom	WBA	If BV is DBV or WBA use D150 *If BV is CBV add D156
ProSlant® 6000	D100-BERM	D150	D156*	D315	D310	D400	M-R0617 or D200 - Custom	WBA	If BV is DBV or WBA use D150 *If BV is CBV add D156
ProSlant® 6000 Without Top	D100-BERM	D150		D315	D310		M-R0617 or D200 - Custom	WBA	If BV is DBV or WBA use D150 *If BV is CBV add D156
Bell Ringer® S5500/S6000 Slant with Bell Feature Top	D100-BERM	D150		D315	D310	D400	M-R0617 or D200 - Custom	DBV-S55 WBA-S6	If BV is DBV or WBA use D150 *If BV is CBV add D156
Roll the Dice® S5500/S6000 Slant with Dice Feature Top	D100-BERM	D150		D315	D310	D400	M-R0617 or D200 - Custom	DBV-S55 WBA-S6	If BV is DBV or WBA use D150 *If BV is CBV add D156
Betty Boop™ S6000 Slant with High Profile Feature Top Box	D100-BERM	D150		D315	D310	D400	M-R0617 or D200 - Custom	WBA	If BV is DBV or WBA use D150 *If BV is CBV add D156

*If Bill Acceptor is **DBV** or **WBA** use **D150** on the BV bezel. If the Bill Acceptor is a **CBV/GPT**, then the following prefixes apply for these models: **S6000 - D156**. If the Bill Acceptor is an older **MARS (VFM4)**, use **D160**.

**DXXX-

-XXXX In the Denomination and Top Award columns show the Prefix and Suffix of the part number, where applicable, (all others columns show the part number series prefix only).

*** Top Award size varies: Sizes A-N, and "Silver and Gold Only."

Shaded areas indicate machines that are no longer produced.



Decal Prefix Index by Machine Model - Video

CABINET	Denomination Decal**	Bill acceptor Bezel Decal	Bill Validator Decal*	Lockup Text Decal	Package Game***	Player Tracking Bracket Overlay	Standard Bill Validator	Additional Info.
V5500 Video Poker	D100-5500	D150		D180 & D190			DBV	
V5500 Plus Video Poker Slant	D100-5500	D150		D180 & D190			DBV	
V5500 Plus Video Poker	D100-5500	D150		D170 & D190			DBV	
Game Maker® V7000 Round Top*	D100-BERM	D150	D156* & D157	D171 w / D100 insert	D201	M-R0617 or D200 - Custom	DBV	If BV is DBV or WBA use D171 *If BV is CBV use D156, D157, D100
Game Maker® V7000 Chop Top*	D100-BERM	D150	D156* & D157	D171 w / D100 insert	D201	M-R0617 or D200 - Custom	DBV	If BV is DBV or WBA use D171 *If BV is CBV use D156, D157, D100
Game Maker® V7000 Casino*	D100-BERM	D150	D156* & D157	D171 w / D100 insert	D201	M-R0617 or D200 - Custom	DBV	If BV is DBV or WBA use D171 *If BV is CBV use D156, D157, D100
V7000/V7200 Slant Round Top	D100-BERM	D150		D170 w / D100 insert	D201	M-R0617 or D200 - Custom	DBV-V7 WBA-V72	If BV is DBV or WBA use D150
Game Maker® V7000 14"	D100-BERM	D150		D170 w / D100 insert	D201	M-R0617 or D200 - Custom	DBV	If BV is DBV or WBA use D170 *If BV is CBV use D156 & D157
Game Maker® V7000 20"	D100-BERM	D150		D170 w / D100 insert	D201	M-R0617 or D200 - Custom	DBV	
Game Maker® V7000 Bartop		D150	D300	None			DBV	
Game Maker® V7000 Slant (France)	D100-BERM	D150	D156* & D157	D171 w / D100 insert	D201	M-R0617 or D200 - Custom	DBV	If BV is DBV or WBA use D171 *If BV is CBV use D156, D157, D100
Game Maker® V7000/V7200 Slant	D100-BERM	D150		D170 w / D100 insert	D201	M-R0617 or D200 - Custom	DBV-V7 WBA-V72	If BV is DBV or WBA use D150
Game Maker® V7000/V7200 Slant Without Top		D150				M-R0617 or D200 - Custom	DBV-V7 WBA-V72	If BV is DBV or WBA use D150
Game Maker® V7000 20" Monitor and Top Box	D100-BERM	D150		D170 w / D100 insert		M-R0617 or D200 - Custom	DBV	Feature Frenzy Top Award, Bonus Game & "Play Up To" decals =D200
Game Maker® V7200	D100-BERM	D150	D161 & D156	D170 w / D100 insert or D310	D201	M-R0617 or D200 - Custom	WBA	If Cash Cage configured, use D150 on BV panel, D170 w / D100; or D310
Game Magic® V8000	D100-BERM	D150	D159 & D156	D158 w / D100 insert		M-R0617 or D200 - Custom	WBA	
Let's Make a Deal™ V8000 With Top Box	D100-BERM	D150	D159 & D156	D158 w / D100 insert		M-R0617 or D200 - Custom	WBA	

*If Bill acceptor is DBV or WBA use D150 on the BV bezel. If the Bill acceptor is a CBV/GPT, then the following prefixes apply for these models: V7000 - D157 & D156; V8000 - D159 & D156.

**DXXX-
-XXXX In the Denomination column show the Prefix and Suffix of the part number, where applicable, (all other columns show the part number series prefix only).

***Package Games require 3 sets of decals: the Package Game logo (D201 series), a coin number decal (D201-00001-COIN) located below the Package Game logo, and a belly glass decal (D201-XXXX-BELLY).

‡ Indicates a video game in a slot cabinet.

Shaded areas indicate machines that are no longer produced.

Glass and Decals

Decal Prefix Description and Sample

Decal Prefix	Decal Series Description	Sample
D100	Denomination Decals (-BERM as suffix, or -5500 [rare])	D100-1C\$+-BERM = 100.00\$ NOTE: Denomination info. is in center text. Suffix is -BERM. See index for -5500 examples.
D150	Bill Validator Bezel Decals - Bill Value Ranges for DBV, WBA and Cash Cage™	D150-00115-LIRA = LIT. 5K, 10K, 50K, 100K / 10K, 50K, 100K NOTE: Decals are model and denomination specific.
D156	Bill Validator decals - Bill Value Ranges for GPT (CBV) Internal, or as an insert with D159 (V8000), or D157 (V7000), D161 (V7200) or G593.	D156-00015-ATS+ = ATS 50, 100, 500, 1000 (Austrian schillings) NOTE: Decals are denomination specific.
D157	V7000 GPT (CBV) Bill Validator Decals (Lockup Text Included)	D157-00001-CBV+ = JACKPOTS OVER 400 COINS PAID BY ATTENDANT NOTE: Decals may be language specific.
D158	V8000 - Lockup Decals	D158-00003-8000 = TOP JACKPOT PAID BY ATTENDANT. NOTE: Decals may be language specific.
D159	V8000 Bill Validator Decals	D159-00006-RED+ = RED GAMEDMAGIC LOGO WITH BILL VALIDATOR NOTE: Decals are game specific.
D161	V7200 Door Panel Decals (Lockup) - English, German, Spanish	D161-00001-ENG+ = DOOR PANEL, WITH BILL VALIDATOR (English Text) NOTE: Text is language specific.
D170	V5500 Plus/ V7000 14" & 20" Lockup Decals	D170-00004-NJ** = 400 COINS OR MORE PAID BY ATTENDANT NOTE: Decals may be language or jurisdiction specific. The D170 and D171 have the same text, but the D171 is slightly larger.
D171	V7000 Slot Cabinet Lockup Decals	D171-00001-CMOD = UP TO 100 COINS PAID BY MACHINE, ALL OTHER WINS PAID BY ATTENDANT. + CREDIT MODE NOTE: Decals may be language or jurisdiction specific. The D170 and D171 have the same text, but the D171 is slightly larger.
D180	V5500 Upright/SlantTop Lockup Decals	D180-00001-++++ = PLAY 1-5 COINS. UP TO (AMT) COINS PAID BY MACHINE, ALL OTHER WINS PAID BY ATTENDANT. NOTE: Decals may be game, language, or jurisdiction specific.
D190	Coin Drop Amount	D190-00001-++++ = Play 1-5 COINS. Used with a D180 decal.
D200	Player Tracking Custom (Bracket) Overlays and Catchall Category	Custom Overlay: D200-00285-++++ = CASINO MAGIC, V7000 OVERLAY 17031. Catchall Series: D200-00027-GL5* = "\$10,000" TOP AWARD, GREEN LIZARD
D201	Package Game Decals	D201-00007-2DBL = DOUBLE DOUBLE BONUS POKER (LOGO FOR PACKAGE FEATURE GLASS)
D220	Win Meter Decal	D220-00001-METR = Win Meter, or D220-00003-FC++ = (French Canadian)
D300	V7000 Bartop Decals - Bill Validator Decals	D300-00007-3XPK = TRIPLE BONUS POKER NOTE: Decals are game specific.
D305	Small Coin Play Decal for Bill Validator Reel Glass: 1-9 coins (mini hotdog)	D305-00001-BERM = PLAY 1 COIN (Old was D105-*****-BERM) NOTE: Text is language specific.
D310	Large Coin Play Decal for No Bill Validator Reel Glass: 1-9 coins	D310-00002-BERM = PLAY 2 COINS (Old was D110-*****-BERM) NOTE: Text is language specific.
D315	Lockup Text for Slots - Hot Dog Style Decal	D315-00001-BERM = ALL JACKPOTS PAID BY MACHINE (Old was D130-*****-BERM) NOTE: Text is language specific.
D320	Lockup Text for Slant Top W/O Top Box - RARE	D320-00001-SLNT = ALL JACKPOTS PAID BY MACHINE (See list for available text 1-39 - New Series)
D325	Lockup Text, Bartop Monitor (Decal) - RARE	D325-00001-BAR+ = ALL JACKPOTS PAID BY MACHINE (See list for available text 1-39 - New Series)
D400	Top Award Inserts for Feature Glass	D400-0030K-00B2 = 30,000, "B" SIZE, SHEET #2 (coin number or \$ amount is in center text; suffix has size & sheet info)
M-R0617	Player Tracking Bracket Overlays - General	M617-0019 = M-R0617-0019 = SDS - WIDE, \$5500, W/ KEYPAD

Decal Examples

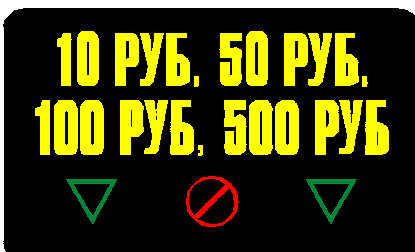

RUSSIAN
S6000 UPRIGHT AND V8000



**VIDEO AND REEL
SLANTS**

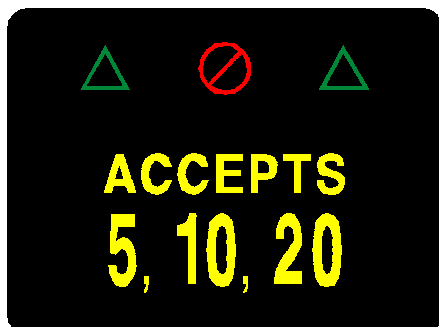

V7200, V7500



*D150-00013-ALL**

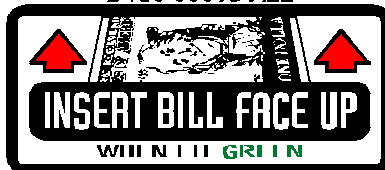

DOMESTIC



CANADA

D150-00045-CAND



CANADA / ENGLISH
V7000 20" UPRIGHT

D150-00046-FCAN



FRENCH / CANADIAN
V7000 20" UPRIGHT & SLANT



D150-00047-FCAN



FRENCH / CANADIAN
S5500 UPRIGHT



D150-00041-CAND

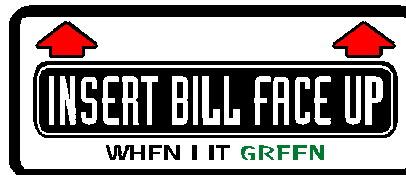

CANADA / ENGLISH
S5500 UPRIGHT & SLANT

D150-00042-AUST

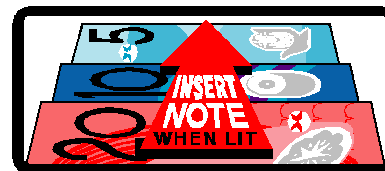

AUSTRALIAN
V7000 20" UPRIGHT

Bill Validator
Bezel Decal
Examples -
D150 Series

Glass and Decals

NOTE: Bill Validator decals are to scale, but are not actual size.

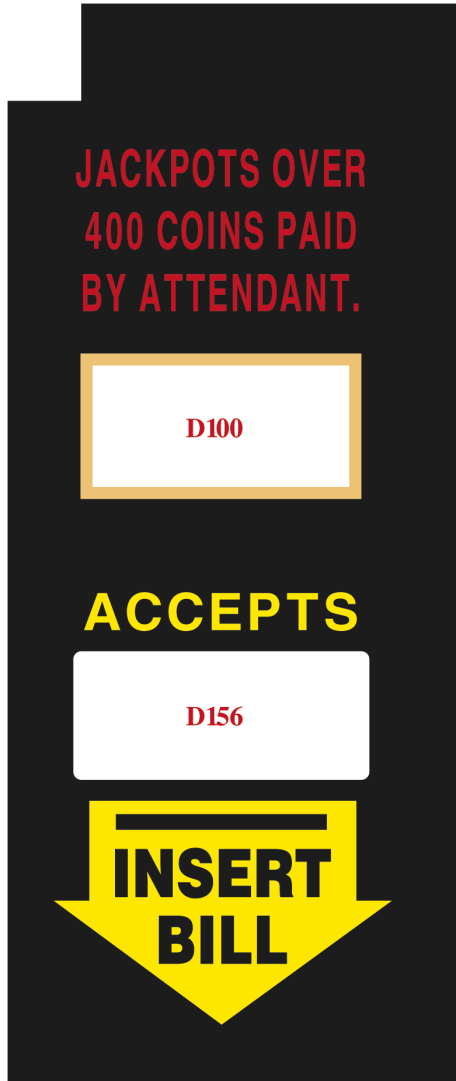

D157 (V7000)



D159 (V8000)

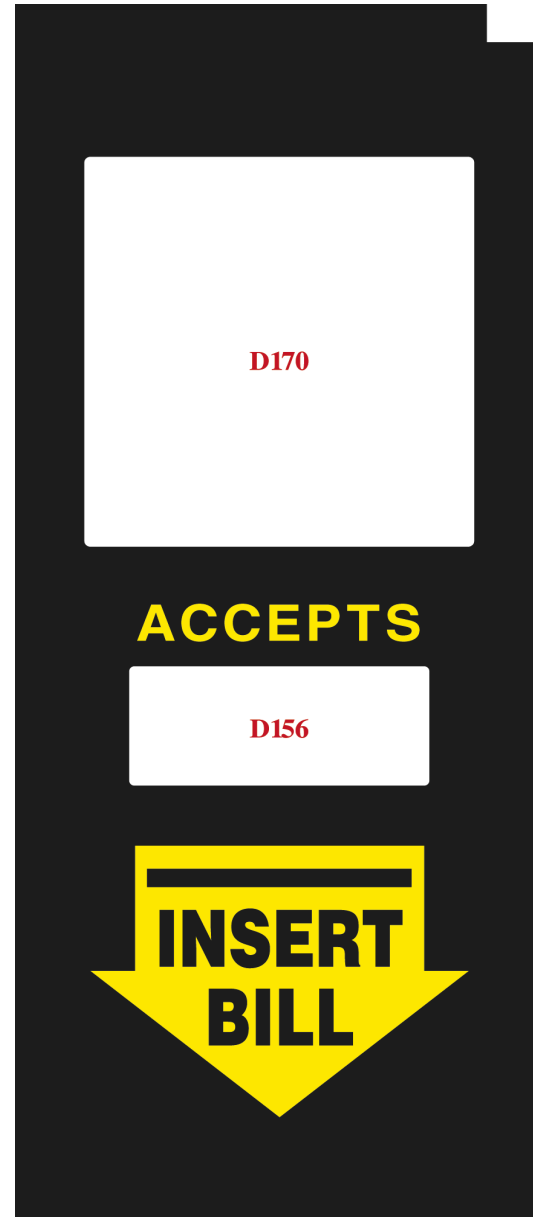

D161 (V7200)

Bill Validator
Examples for
V7000 (D157),
V8000 (D159),
and V7200
(D161)

ALL JACKPOTS PAID BY MACHINE.

D315 LOCKUP (HOTDOG)



D310 REEL SLANT



D310 REEL



D305 REEL

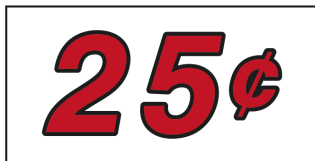

D100 DENOMINATION

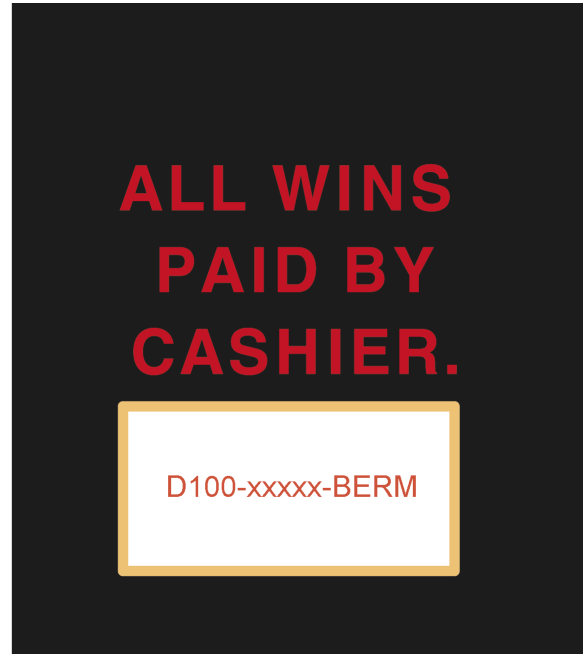

D170 LOCKUP*



D158 (V8000 LOCKUP)



D156 BILL RANGE

Decal Examples:
Hotdog Lockup for
reels (D315),
Play Coin Decal
(D310 & D305),
D170 & D158
Lockup Decals, and
D100-xxxxx-BERM
Denomination
Decal

NOTE: Decals are to
scale but are not
actual size.

*Text options and appearance of the D170 and D171 (not shown) are the same, but the size of the decals varies slightly. Please see the Decal Prefix Index Table or the Model Image section for machine-specific information.

Glass and Decals

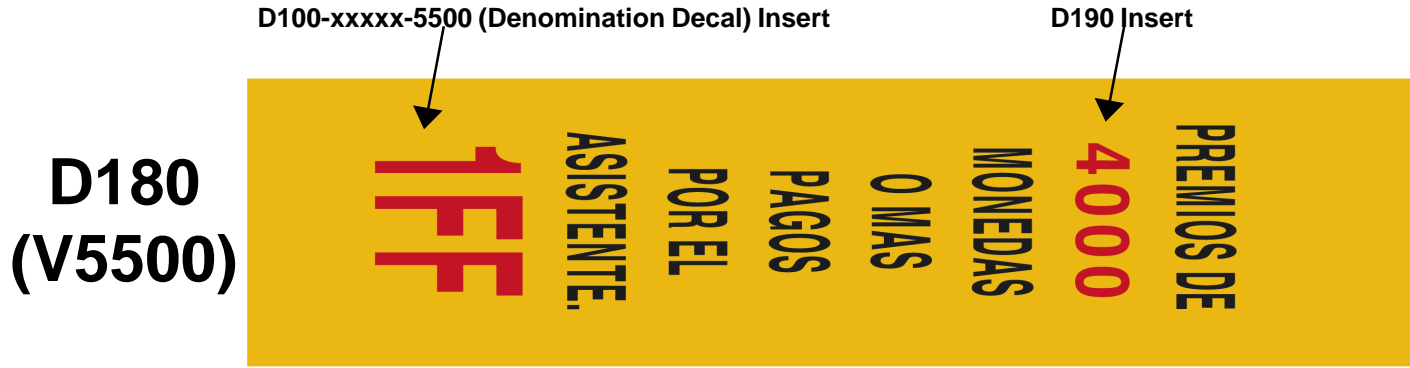

Decal Examples:
 D180 - Lockup for the V5500; D300 - Bill Validator for the Bartop



D300 - Bartop (External)

NOTE: Decals are to scale, but are not actual size.

Examples - Package
Game Decals: D201,
D201-00001-COIN,
D201-xxxxx-BELY, and
the Top Award Insert,
D400 - "I" Size



D201



D400
(I) SIZE



D201-0001-COIN



D201-xxxxx-BELY

NOTE: Decals
are to scale,
but are not
actual size.

Glass and Decals

Decal Sizes - Black and White Outlines - Actual Size

This section shows an outline from each series of decals. The exact size is shown so that when selecting a replacement, the size can be measured against these outlines to ensure that the correct decal is being requested. Refer to the Machine Image section for exact decal placement on the machine, or the Decal Prefix Index table at the front of this module for model-specific decal information. The decal outlines shown here do not include the stroke (small extension beyond the decal size which is covered by the window opening outline) in the dimensions.

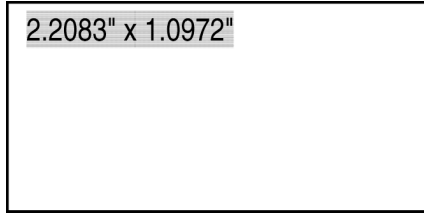

D100-xxxxx-BERM

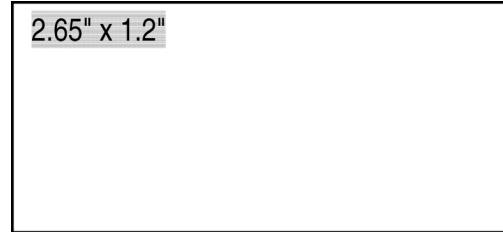

D156

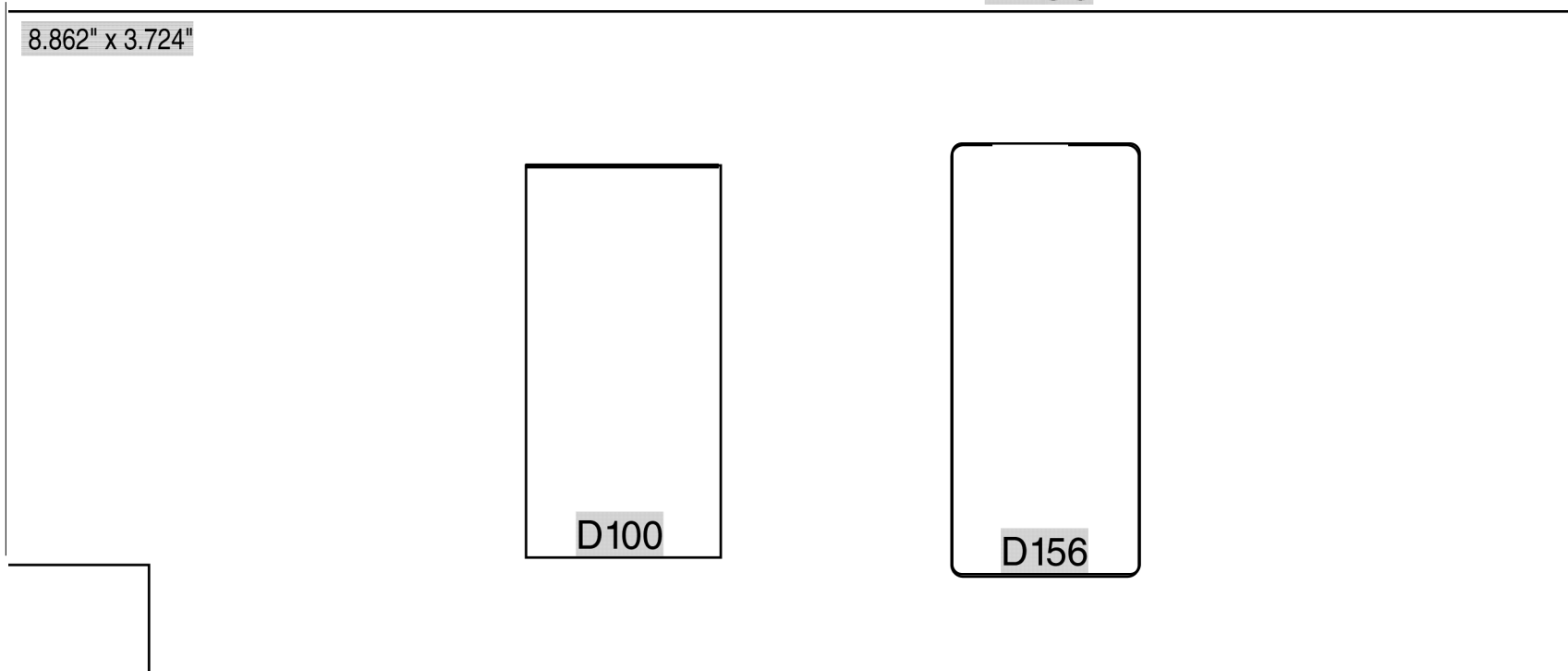

D157 V7000

**Bill Validator
D157 for the
V7000 with
D100 and D156
Inserts**



**Bill Validator
D159 for the
V8000 with
D156 Insert**

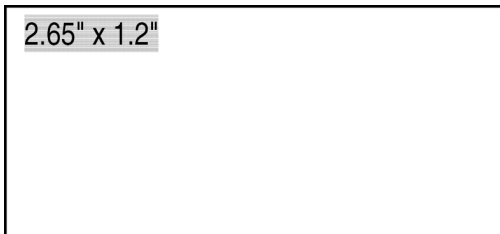

2.65" x 1.2"

D156

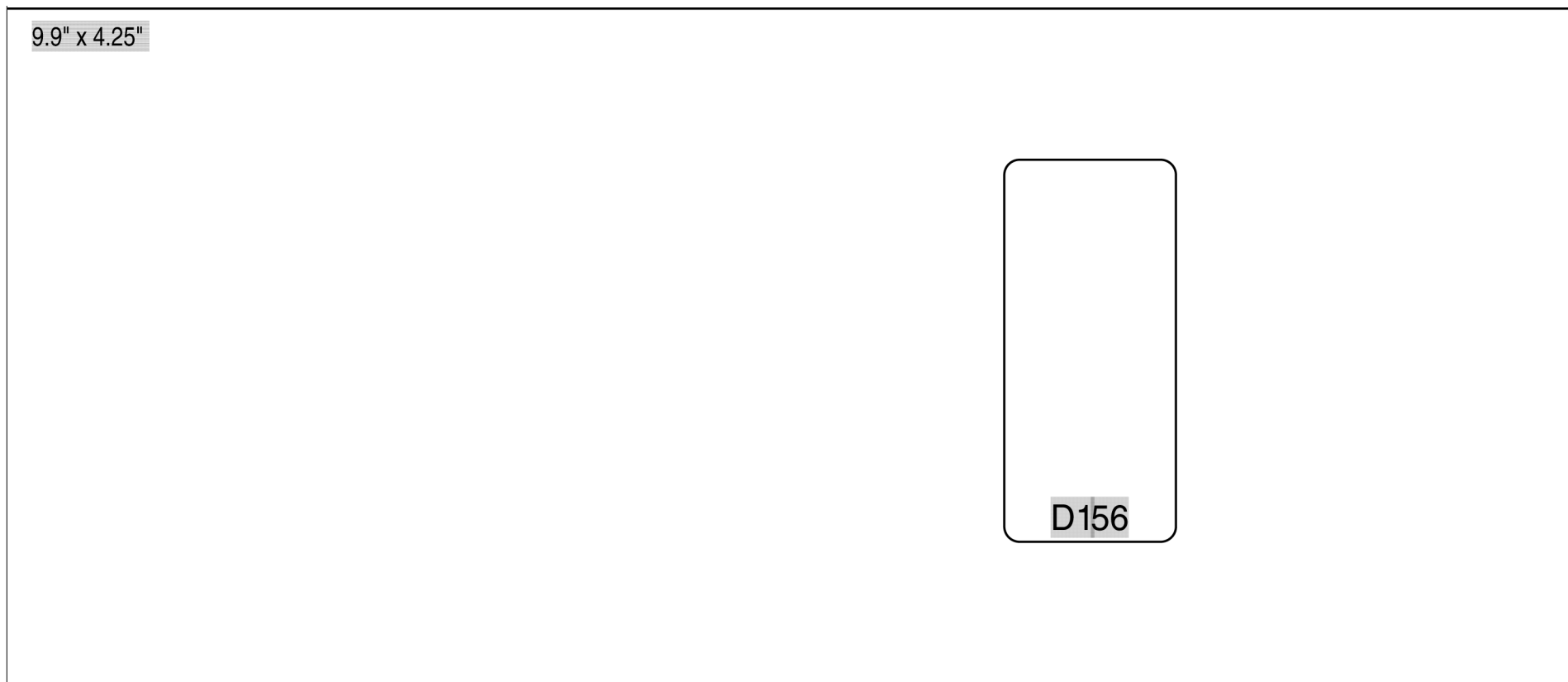

9.9" x 4.25"

D156

D159 (V8000)

Glass and Decals

Bill Validator for
the V7200 with
D170, (not shown)
D100 and D156
Inserts

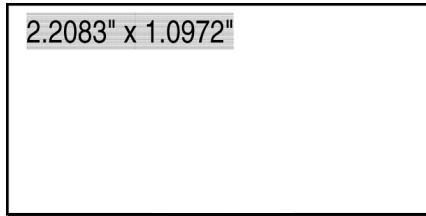

D100-xxxxx-BERM

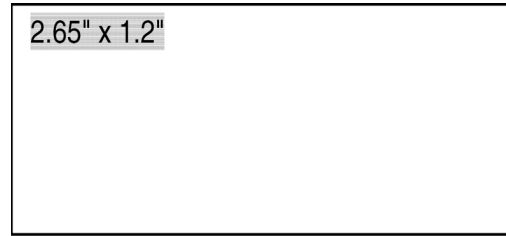

D156

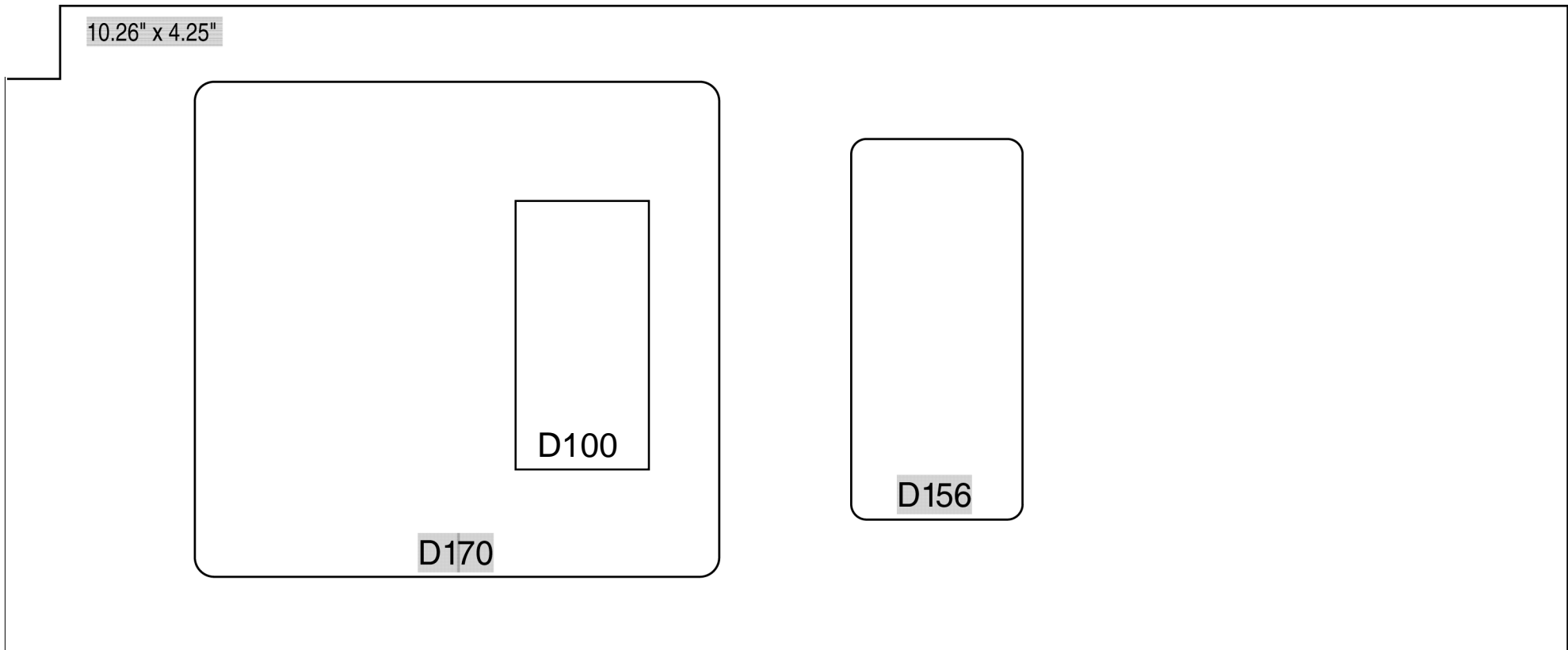

D161 (V7200)



**Bill Validator for
the V5500 with
D190, and D100
Inserts**

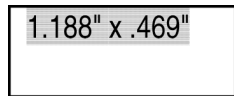

D190

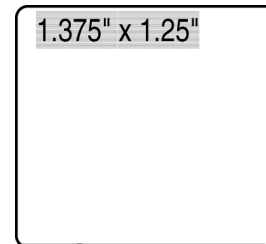

D100-xxxxx-5500

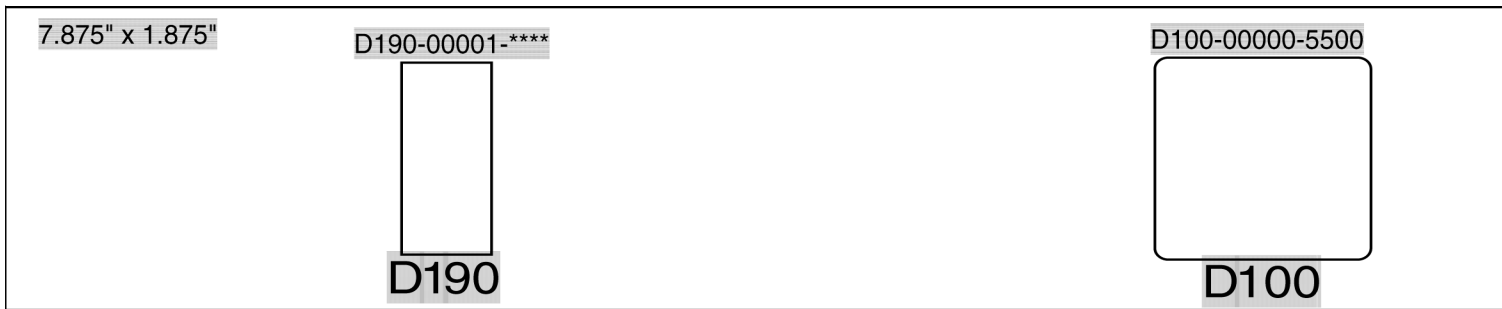

D180

Glass and Decals

Bill Validator for the V7000 Bartop D300 and Lockup Text Hotdog Decal D315 for Reel Machines

9.75" x 5"

D300 BARTOP

.9496" x 9.6562"

D315

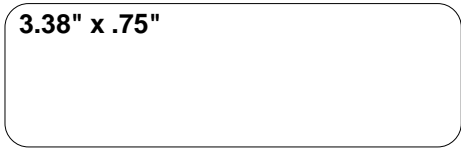

3.38" x .75"



2.64" x .53"

**D150 for S5500 & V7000 UPRIGHT
& SLANT "ACCEPTS" RANGE**

**Bill Validator
Bezel Decals:
D150 Series
(Not all options
shown here.)**



4.03" x .88"

D150s for S6000 and V7200 SLANTS

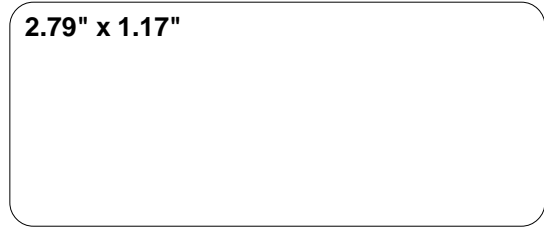

2.79" x 1.17"

**D150 for S5500
UPRIGHT & SLANT**

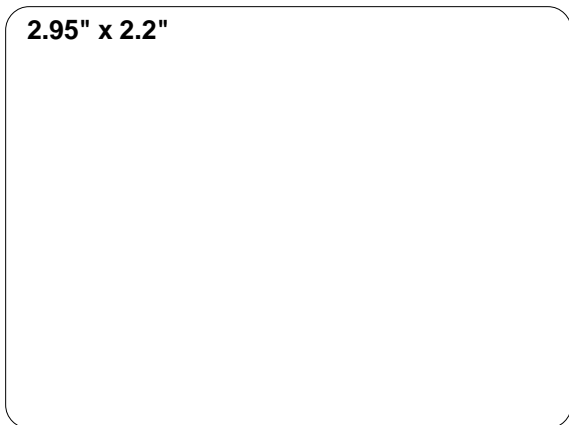

2.95" x 2.2"

D150 for V7200 and V7500

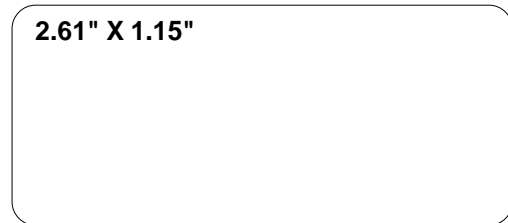

2.61" X 1.15"

D150 for V7000 20" UPRIGHT

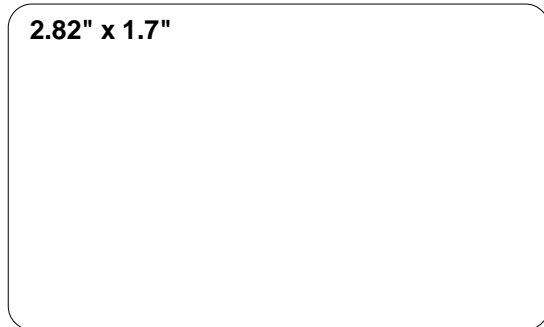

2.82" x 1.7"

D150 for S6000 UPRIGHT

Glass and Decals

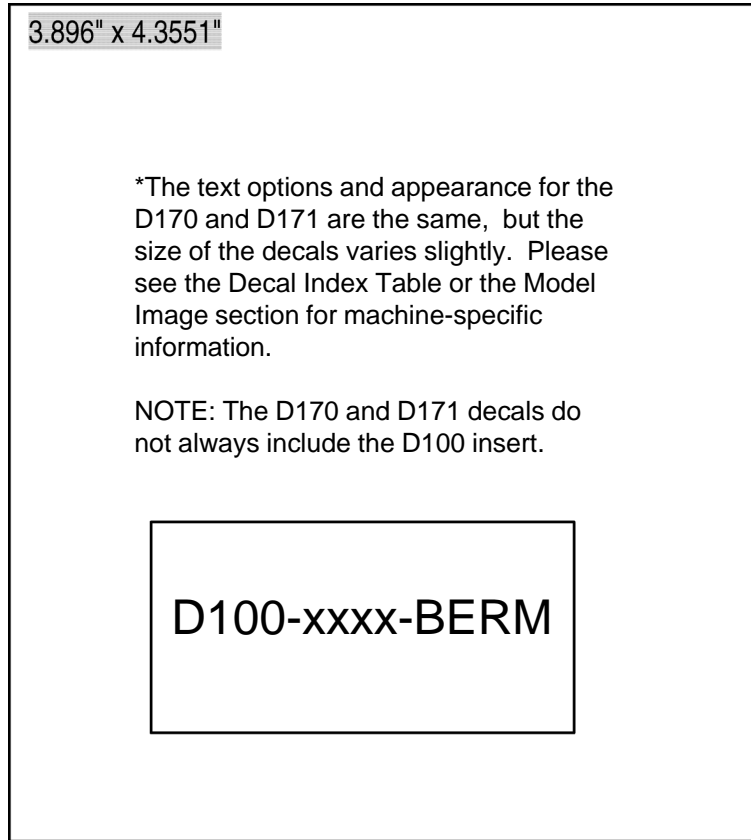

D170*

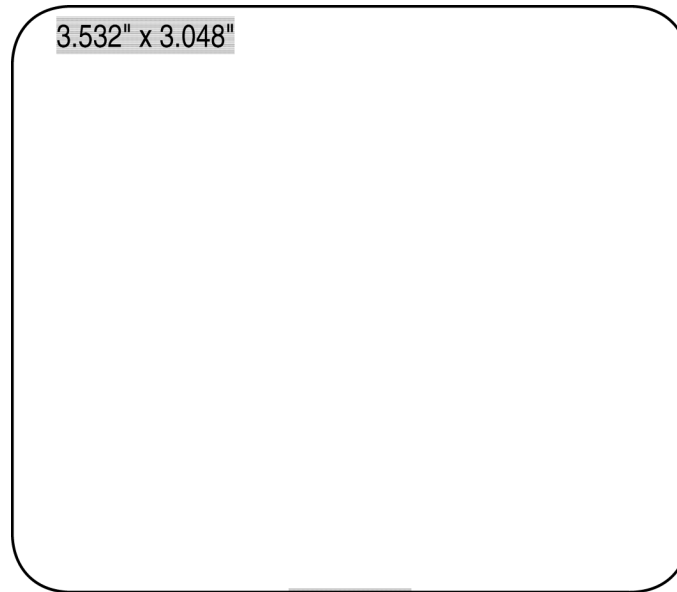

D201

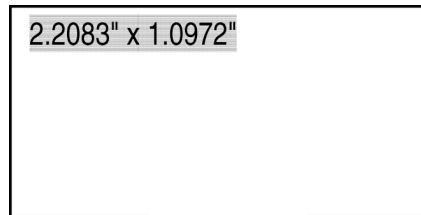

D100-xxxx-BERM

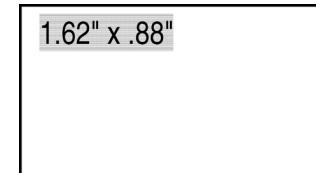

D201-00001-COIN

**Decal Inserts -
D100-xxxx-BERM:
Denomination;
D170: Lockup Text**

**Package Game
Decals: D201,
D201-00001-COIN,
and
D201-xxxxx-BELY**



D201-xxxxx-BELY**

**The ends of this decal outline will be cut off due to printing restrictions, however, the measurements stated are correct, and the outline is actual size.



The D200 series decal will not be displayed here because no single decal is representative of the group. The D160, D220, D320, and D325 series decals will not be shown here because of their rare occurrence. Please consult the Decal Prefix Index table for examples of their use.

Decal Inserts - Coin Play Decals: D305, and D310 for Slant and Upright; D100-xxxxx-5500 (denom.) and D190 for V5500; D156: Bill Validator Bill Value Decal; and Lockup Text for the V8000: D158 with D100 (denom.) insert

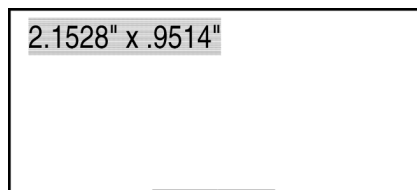

D305

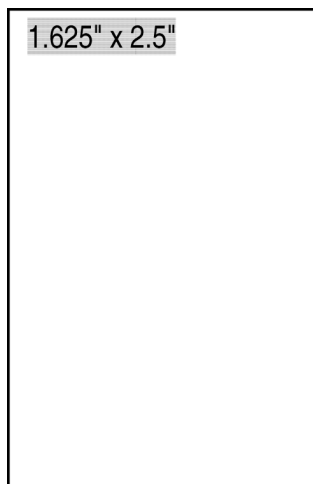

D310 (SLANT)*

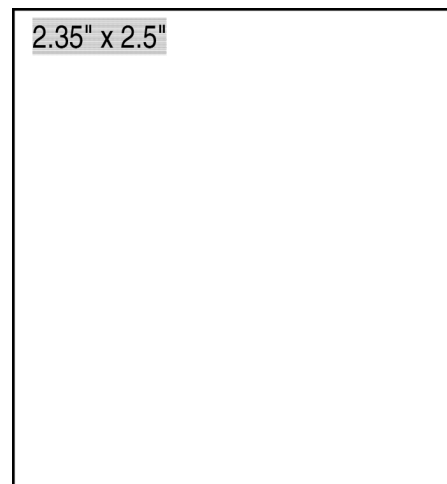

D310 (UPRIGHT)*

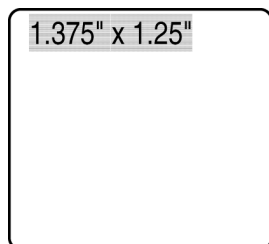

D100-xxxxx-5500

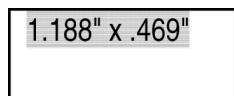

D190

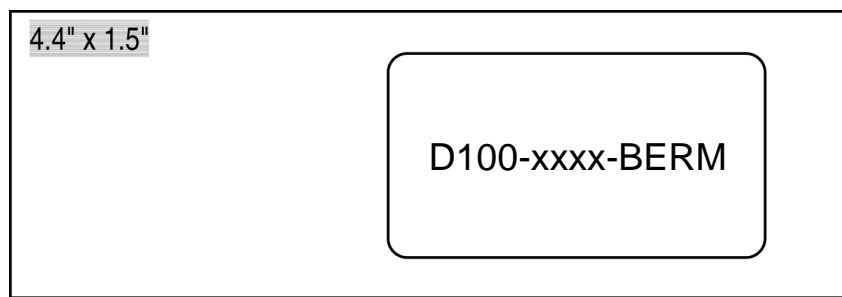

D158 (V8000)

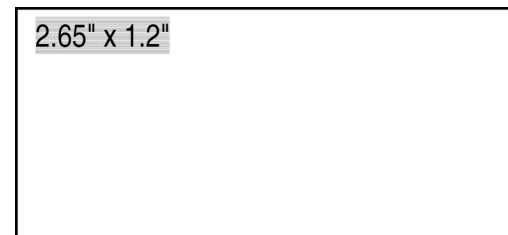

D156

*The D310 decals have some size variations within the series (shown above) as do the D150 Bill Validator Bezel decal series. If the size of the decal does not match one of these outlines, refer to the machine-specific images for exact decal locations or the Decal Prefix Index table for model-specific decal usage.

Glass and Decals

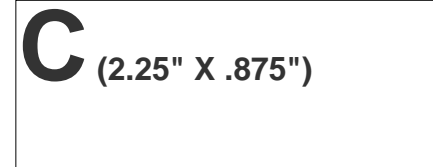
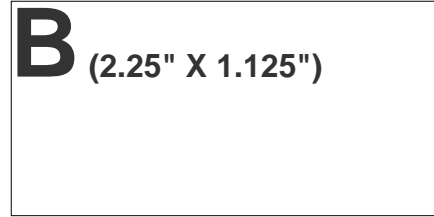
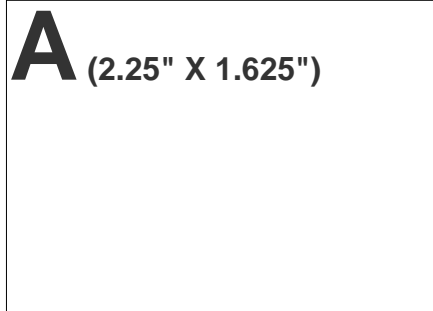

Top Award /
Feature Glass
Decal D400
Series
Standard
Window
Openings

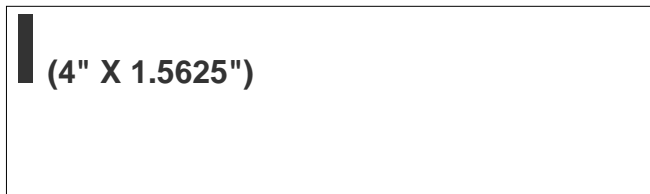
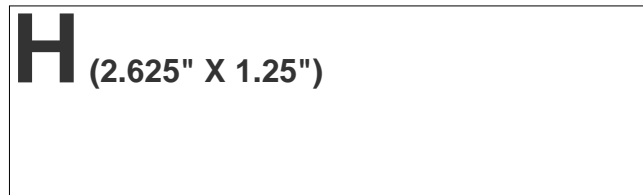
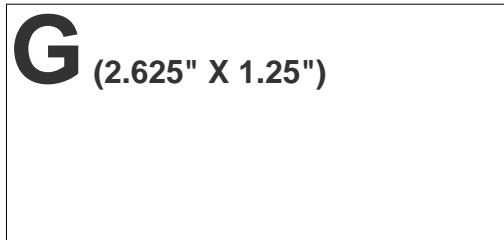
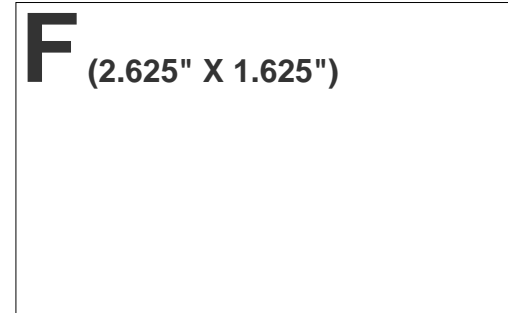

NOTE: All windows are exact size **without** stroke.



K (5.625" X 1.5")

L (3.375" X 1.2812")

M (3.68" X 1.114")
5 - Line

N (4.2833" X 1.6375")
3 - Line

**Silver and Gold
Only** (6" X 2")

Top Award/
Feature Glass
Decal D400
Series
Standard
Window
Openings
(continued)

NOTE: All windows are exact size **without** stroke.

Glass and Decals

Glass and Decals

Machine Model Numbering Convention

This section shows the breakdown of Machine Model Numbers. The Machine Model Number, the serial number and the manufacturing date, are located on the Bally Gaming identification plate on the lower right side of the cabinet. Use the following tables to identify the machine model for which you are ordering parts. Please refer to the machine model number, in addition to the glass and decal prefixes listed, when ordering parts.

Pos 1	Pos 2	Pos 3	Pos 4	Pos 5	Pos 6	Pos 7	Pos 8	Pos 9																																																																																																																																																																																																																																																																																																									
Reel Model Numbers																																																																																																																																																																																																																																																																																																																	
<table border="1" style="width: 100%; border-collapse: collapse;"> <tr> <td style="width: 12.5%;">Pos 1</td> <td style="width: 12.5%;"></td> <td style="width: 12.5%;"></td> <td style="width: 12.5%;"></td> <td style="width: 12.5%;"></td> <td style="width: 12.5%;"></td> <td style="width: 12.5%;"></td> <td style="width: 12.5%;"></td> <td style="width: 12.5%;"></td> </tr> <tr> <td>S = Slot</td> <td></td> <td></td> <td></td> <td></td> <td></td> <td></td> <td></td> <td></td> </tr> <tr> <td>Pos 2</td> <td></td> <td></td> <td></td> <td></td> <td></td> <td></td> <td></td> <td></td> </tr> <tr> <td>6 = Coincidental</td> <td></td> <td></td> <td></td> <td></td> <td></td> <td></td> <td></td> <td></td> </tr> <tr> <td>Pos 3 & 4</td> <td></td> <td></td> <td></td> <td></td> <td></td> <td></td> <td></td> <td></td> </tr> <tr> <td>2M = 2 Coin Multiplier</td> <td></td> <td></td> <td></td> <td></td> <td></td> <td></td> <td></td> <td></td> </tr> <tr> <td>3M = 3 Coin Multiplier</td> <td></td> <td></td> <td></td> <td></td> <td></td> <td></td> <td></td> <td></td> </tr> <tr> <td>3L = 3 Pay Lines</td> <td></td> <td></td> <td></td> <td></td> <td></td> <td></td> <td></td> <td></td> </tr> <tr> <td>5L = 5 Pay Lines</td> <td></td> <td></td> <td></td> <td></td> <td></td> <td></td> <td></td> <td></td> </tr> <tr> <td>2B = 2 Coin Buy</td> <td></td> <td></td> <td></td> <td></td> <td></td> <td></td> <td></td> <td></td> </tr> <tr> <td>3B = 3 Coin Buy</td> <td></td> <td></td> <td></td> <td></td> <td></td> <td></td> <td></td> <td></td> </tr> <tr> <td>4U = Multiplier W/Buy</td> <td></td> <td></td> <td></td> <td></td> <td></td> <td></td> <td></td> <td></td> </tr> <tr> <td>Pos 5</td> <td></td> <td></td> <td></td> <td></td> <td></td> <td></td> <td></td> <td></td> </tr> <tr> <td>3 = 3 Reels</td> <td></td> <td></td> <td></td> <td></td> <td></td> <td></td> <td></td> <td></td> </tr> <tr> <td>4 = 4 Reels</td> <td></td> <td></td> <td></td> <td></td> <td></td> <td></td> <td></td> <td></td> </tr> <tr> <td>5 = 5 Reels</td> <td></td> <td></td> <td></td> <td></td> <td></td> <td></td> <td></td> <td></td> </tr> <tr> <td>Pos 6 & 7</td> <td></td> <td></td> <td></td> <td></td> <td></td> <td></td> <td></td> <td></td> </tr> <tr> <td><i>Upright</i></td> <td></td> <td></td> <td></td> <td></td> <td></td> <td></td> <td></td> <td></td> </tr> <tr> <td>W6 = Casino Style Top Box</td> <td></td> <td></td> <td></td> <td></td> <td></td> <td></td> <td></td> <td>\$6000</td> </tr> <tr> <td>C6 = Chop Style Top Box</td> <td></td> <td></td> <td></td> <td></td> <td></td> <td></td> <td></td> <td>\$6000</td> </tr> <tr> <td>R6 = Round Style Top Box</td> <td></td> <td></td> <td></td> <td></td> <td></td> <td></td> <td></td> <td>\$6000</td> </tr> <tr> <td>BS = Anchor Big Slot</td> <td></td> <td></td> <td></td> <td></td> <td></td> <td></td> <td></td> <td>S5500</td> </tr> <tr> <td><i>Slant Top</i></td> <td></td> <td></td> <td></td> <td></td> <td></td> <td></td> <td></td> <td></td> </tr> <tr> <td>B6 = Standard Top Box</td> <td></td> <td></td> <td></td> <td></td> <td></td> <td></td> <td></td> <td>\$6000</td> </tr> <tr> <td>D6 = Round Top Box</td> <td></td> <td></td> <td></td> <td></td> <td></td> <td></td> <td></td> <td>\$6000</td> </tr> <tr> <td>M6 = Maps Top Box</td> <td></td> <td></td> <td></td> <td></td> <td></td> <td></td> <td></td> <td>\$6000</td> </tr> <tr> <td>C6 = Dice Game Top Box</td> <td></td> <td></td> <td></td> <td></td> <td></td> <td></td> <td></td> <td>\$6000</td> </tr> <tr> <td>R6 = Bell Ringer® Top</td> <td></td> <td></td> <td></td> <td></td> <td></td> <td></td> <td></td> <td>\$6000</td> </tr> <tr> <td>B0 = Standard Top Box</td> <td></td> <td></td> <td></td> <td></td> <td></td> <td></td> <td></td> <td>S5500</td> </tr> <tr> <td>D0 = Round Top Box</td> <td></td> <td></td> <td></td> <td></td> <td></td> <td></td> <td></td> <td>S5500</td> </tr> <tr> <td>C0 = Roll the Dice® Top Box</td> <td></td> <td></td> <td></td> <td></td> <td></td> <td></td> <td></td> <td>S5500</td> </tr> <tr> <td>R0 = Bell Ringer® Top</td> <td></td> <td></td> <td></td> <td></td> <td></td> <td></td> <td></td> <td>S5500</td> </tr> <tr> <td>00 = No Top Box</td> <td></td> <td></td> <td></td> <td></td> <td></td> <td></td> <td></td> <td>\$55 / \$6</td> </tr> </table>									Pos 1									S = Slot									Pos 2									6 = Coincidental									Pos 3 & 4									2M = 2 Coin Multiplier									3M = 3 Coin Multiplier									3L = 3 Pay Lines									5L = 5 Pay Lines									2B = 2 Coin Buy									3B = 3 Coin Buy									4U = Multiplier W/Buy									Pos 5									3 = 3 Reels									4 = 4 Reels									5 = 5 Reels									Pos 6 & 7									<i>Upright</i>									W6 = Casino Style Top Box								\$6000	C6 = Chop Style Top Box								\$6000	R6 = Round Style Top Box								\$6000	BS = Anchor Big Slot								S5500	<i>Slant Top</i>									B6 = Standard Top Box								\$6000	D6 = Round Top Box								\$6000	M6 = Maps Top Box								\$6000	C6 = Dice Game Top Box								\$6000	R6 = Bell Ringer® Top								\$6000	B0 = Standard Top Box								S5500	D0 = Round Top Box								S5500	C0 = Roll the Dice® Top Box								S5500	R0 = Bell Ringer® Top								S5500	00 = No Top Box								\$55 / \$6
Pos 1																																																																																																																																																																																																																																																																																																																	
S = Slot																																																																																																																																																																																																																																																																																																																	
Pos 2																																																																																																																																																																																																																																																																																																																	
6 = Coincidental																																																																																																																																																																																																																																																																																																																	
Pos 3 & 4																																																																																																																																																																																																																																																																																																																	
2M = 2 Coin Multiplier																																																																																																																																																																																																																																																																																																																	
3M = 3 Coin Multiplier																																																																																																																																																																																																																																																																																																																	
3L = 3 Pay Lines																																																																																																																																																																																																																																																																																																																	
5L = 5 Pay Lines																																																																																																																																																																																																																																																																																																																	
2B = 2 Coin Buy																																																																																																																																																																																																																																																																																																																	
3B = 3 Coin Buy																																																																																																																																																																																																																																																																																																																	
4U = Multiplier W/Buy																																																																																																																																																																																																																																																																																																																	
Pos 5																																																																																																																																																																																																																																																																																																																	
3 = 3 Reels																																																																																																																																																																																																																																																																																																																	
4 = 4 Reels																																																																																																																																																																																																																																																																																																																	
5 = 5 Reels																																																																																																																																																																																																																																																																																																																	
Pos 6 & 7																																																																																																																																																																																																																																																																																																																	
<i>Upright</i>																																																																																																																																																																																																																																																																																																																	
W6 = Casino Style Top Box								\$6000																																																																																																																																																																																																																																																																																																									
C6 = Chop Style Top Box								\$6000																																																																																																																																																																																																																																																																																																									
R6 = Round Style Top Box								\$6000																																																																																																																																																																																																																																																																																																									
BS = Anchor Big Slot								S5500																																																																																																																																																																																																																																																																																																									
<i>Slant Top</i>																																																																																																																																																																																																																																																																																																																	
B6 = Standard Top Box								\$6000																																																																																																																																																																																																																																																																																																									
D6 = Round Top Box								\$6000																																																																																																																																																																																																																																																																																																									
M6 = Maps Top Box								\$6000																																																																																																																																																																																																																																																																																																									
C6 = Dice Game Top Box								\$6000																																																																																																																																																																																																																																																																																																									
R6 = Bell Ringer® Top								\$6000																																																																																																																																																																																																																																																																																																									
B0 = Standard Top Box								S5500																																																																																																																																																																																																																																																																																																									
D0 = Round Top Box								S5500																																																																																																																																																																																																																																																																																																									
C0 = Roll the Dice® Top Box								S5500																																																																																																																																																																																																																																																																																																									
R0 = Bell Ringer® Top								S5500																																																																																																																																																																																																																																																																																																									
00 = No Top Box								\$55 / \$6																																																																																																																																																																																																																																																																																																									
<table border="1" style="width: 100%; border-collapse: collapse;"> <tr> <td style="width: 12.5%;">Pos 8</td> <td style="width: 12.5%;"></td> <td style="width: 12.5%;"></td> <td style="width: 12.5%;"></td> <td style="width: 12.5%;"></td> <td style="width: 12.5%;"></td> <td style="width: 12.5%;"></td> <td style="width: 12.5%;"></td> <td style="width: 12.5%;"></td> </tr> <tr> <td>F = Bill Validator</td> <td></td> <td></td> <td></td> <td></td> <td></td> <td></td> <td></td> <td>\$6000</td> </tr> <tr> <td>C = Cash Cage™</td> <td></td> <td></td> <td></td> <td></td> <td></td> <td></td> <td></td> <td>\$6000</td> </tr> <tr> <td>P = Bill Validator / Progressive</td> <td></td> <td></td> <td></td> <td></td> <td></td> <td></td> <td></td> <td>\$6000</td> </tr> <tr> <td>B = Bill Validator / Cash Cage™</td> <td></td> <td></td> <td></td> <td></td> <td></td> <td></td> <td></td> <td>\$6000</td> </tr> <tr> <td>E = Bill Validator / Cash Cage™ / Progressive</td> <td></td> <td></td> <td></td> <td></td> <td></td> <td></td> <td></td> <td>\$6000</td> </tr> <tr> <td>N = No Bill Validator / No Progressive / No Cash Cage™</td> <td></td> <td></td> <td></td> <td></td> <td></td> <td></td> <td></td> <td>\$6000</td> </tr> <tr> <td>0 = No Bill Validator / No Progressive</td> <td></td> <td></td> <td></td> <td></td> <td></td> <td></td> <td></td> <td>S5500</td> </tr> <tr> <td>1 = Bill Validator</td> <td></td> <td></td> <td></td> <td></td> <td></td> <td></td> <td></td> <td>S5500</td> </tr> <tr> <td>2 = Bill Validator / Progressive</td> <td></td> <td></td> <td></td> <td></td> <td></td> <td></td> <td></td> <td>S5500</td> </tr> <tr> <td>Pos 9</td> <td colspan="8"><i>for Slants = Deck / Top Box Color</i></td> </tr> <tr> <td>0 = Chrome</td> <td colspan="8"><i>for Uprights = Door Finish</i></td> </tr> <tr> <td>1 = Polished Brass</td> <td colspan="8"></td> </tr> <tr> <td>2 = Chrome & Brass</td> <td colspan="8"></td> </tr> <tr> <td>3 = Black Nickel</td> <td colspan="8"></td> </tr> <tr> <td>4 = Polished Gold</td> <td colspan="8"></td> </tr> <tr> <td>5 = Powder Coating</td> <td colspan="8"></td> </tr> <tr> <td>6 = Polished Stainless</td> <td colspan="8"></td> </tr> <tr> <td>7 = Brushed Stainless</td> <td colspan="8"></td> </tr> <tr> <td>8 = Brushed Brass</td> <td colspan="8"></td> </tr> </table>									Pos 8									F = Bill Validator								\$6000	C = Cash Cage™								\$6000	P = Bill Validator / Progressive								\$6000	B = Bill Validator / Cash Cage™								\$6000	E = Bill Validator / Cash Cage™ / Progressive								\$6000	N = No Bill Validator / No Progressive / No Cash Cage™								\$6000	0 = No Bill Validator / No Progressive								S5500	1 = Bill Validator								S5500	2 = Bill Validator / Progressive								S5500	Pos 9	<i>for Slants = Deck / Top Box Color</i>								0 = Chrome	<i>for Uprights = Door Finish</i>								1 = Polished Brass									2 = Chrome & Brass									3 = Black Nickel									4 = Polished Gold									5 = Powder Coating									6 = Polished Stainless									7 = Brushed Stainless									8 = Brushed Brass																																																																																																																													
Pos 8																																																																																																																																																																																																																																																																																																																	
F = Bill Validator								\$6000																																																																																																																																																																																																																																																																																																									
C = Cash Cage™								\$6000																																																																																																																																																																																																																																																																																																									
P = Bill Validator / Progressive								\$6000																																																																																																																																																																																																																																																																																																									
B = Bill Validator / Cash Cage™								\$6000																																																																																																																																																																																																																																																																																																									
E = Bill Validator / Cash Cage™ / Progressive								\$6000																																																																																																																																																																																																																																																																																																									
N = No Bill Validator / No Progressive / No Cash Cage™								\$6000																																																																																																																																																																																																																																																																																																									
0 = No Bill Validator / No Progressive								S5500																																																																																																																																																																																																																																																																																																									
1 = Bill Validator								S5500																																																																																																																																																																																																																																																																																																									
2 = Bill Validator / Progressive								S5500																																																																																																																																																																																																																																																																																																									
Pos 9	<i>for Slants = Deck / Top Box Color</i>																																																																																																																																																																																																																																																																																																																
0 = Chrome	<i>for Uprights = Door Finish</i>																																																																																																																																																																																																																																																																																																																
1 = Polished Brass																																																																																																																																																																																																																																																																																																																	
2 = Chrome & Brass																																																																																																																																																																																																																																																																																																																	
3 = Black Nickel																																																																																																																																																																																																																																																																																																																	
4 = Polished Gold																																																																																																																																																																																																																																																																																																																	
5 = Powder Coating																																																																																																																																																																																																																																																																																																																	
6 = Polished Stainless																																																																																																																																																																																																																																																																																																																	
7 = Brushed Stainless																																																																																																																																																																																																																																																																																																																	
8 = Brushed Brass																																																																																																																																																																																																																																																																																																																	



Video Model Numbers

Pos 1	Pos 2	Pos 3	Pos 4	Pos 5	Pos 6	Pos 7	Pos 8	Pos 9																																																																																																																																																																																																																																							
<table border="1"> <tr> <td colspan="3">Pos 1</td> <td colspan="3">Pos 7</td> <td colspan="3"></td> </tr> <tr> <td colspan="3">V = Video</td> <td colspan="3">F = Bill Validator</td> <td colspan="3">V7200 / V8000 / V8500</td> </tr> <tr> <td colspan="3"></td> <td colspan="3">C = Cash Cage™</td> <td colspan="3">V7200 / V8000 / V8500</td> </tr> <tr> <td colspan="3">Pos 2,3,4</td> <td colspan="3">B = Bill Validator / Cash Cage™</td> <td colspan="3">V7200 / V8000 / V8500</td> </tr> <tr> <td colspan="3">MPL = Multi Game Capable</td> <td colspan="3">P = Bill Validator / Progressive</td> <td colspan="3">V7200 / V8000 / V8500</td> </tr> <tr> <td colspan="3">POK = Poker (V5500)</td> <td colspan="3">E = Bill Validator / Cash Cage™ / Progressive</td> <td colspan="3">V7200 / V8000 / V8500</td> </tr> <tr> <td colspan="3"></td> <td colspan="3">N = No Bill Validator / No Progressive / No Cash Cage™</td> <td colspan="3">V7200 / V8000 / V8500</td> </tr> <tr> <td colspan="3">Pos 5</td> <td colspan="3">0 = Non Progressive No Bill Validator</td> <td colspan="3">V7 20" / V7 w TB / V7 Bar</td> </tr> <tr> <td colspan="3">0 = Default</td> <td colspan="3">1 = Bill Validator No Progressive</td> <td colspan="3">V7 20" / V7 w TB / V7 Bar</td> </tr> <tr> <td colspan="3">A = V8500 14"</td> <td colspan="3">6 = Barcode Bill Non Progressive</td> <td colspan="3">V7 20" / V7 w TB / V7 Bar</td> </tr> <tr> <td colspan="3">B = V8500 17"</td> <td colspan="3"></td> <td colspan="3"></td> </tr> <tr> <td colspan="3">C = V8500 20" Horizontal</td> <td colspan="3"></td> <td colspan="3"></td> </tr> <tr> <td colspan="3">D = V8500 20" Vertical</td> <td colspan="3"></td> <td colspan="3"></td> </tr> <tr> <td colspan="3">3 = Video w/ Round top box</td> <td colspan="3"></td> <td colspan="3"></td> </tr> <tr> <td colspan="3">4 = V7000 w/ 20" monitor & top box</td> <td colspan="3"></td> <td colspan="3"></td> </tr> <tr> <td colspan="3">5 = V72 Slant 17" Monitor</td> <td colspan="3"></td> <td colspan="3"></td> </tr> <tr> <td colspan="3">6 = V72 Slant 12-button Deck</td> <td colspan="3"></td> <td colspan="3"></td> </tr> <tr> <td colspan="3">8 = V8 With Square Top</td> <td colspan="3"></td> <td colspan="3"></td> </tr> <tr> <td colspan="3">9 = V8 With Round Top</td> <td colspan="3"></td> <td colspan="3"></td> </tr> <tr> <td colspan="3"></td> <td colspan="3"></td> <td colspan="3"></td> </tr> <tr> <td colspan="3">Pos 6</td> <td colspan="3">Pos 8</td> <td colspan="3" rowspan="2"> <i>for Slants = Deck / Top Box Color</i> <i>for Uprights = Door Finish</i> </td> </tr> <tr> <td colspan="3"> <i>Upright Cabinet Style</i> N = 14" Monitor (V7 / V72) Q = 20" Monitor (V7) M = V8000 20" upright L = V8000 LMAD W = Casino Style Top Box C = Chop Style Top Box R = Round Top Box X = Standard Cabinet <i>All Video Slant Top</i> F = Bar Top 0 = Slant Top / No Top Box S = Slant Top Standard Top Box D = Slant Top Round Top Box </td> <td colspan="3"> Pos 9 1 = Touch Screen / Printer 2 = Touch Screen / Hopper 3 = Buttons / Printer 4 = Buttons / Hopper 5 = Touch Screen / Buttons / Printer 6 = Touch Screen / Buttons / Hopper 7 = Touch Screen / Buttons </td> </tr> <tr> <td colspan="3"></td> <td colspan="3"></td> <td colspan="3"> <table border="1"> <tr> <td>Position 1</td> <td>Position 2</td> <td>Position 3</td> <td>Position 4</td> <td>Position 5</td> <td>Position 6</td> <td>Position 7</td> <td>Position 8</td> <td>Position 9</td> </tr> <tr> <td>V</td> <td>M</td> <td>P</td> <td>L</td> <td>0</td> <td>N</td> <td>F</td> <td>0</td> <td>6</td> </tr> </table> </td> </tr> <tr> <td colspan="3"></td> <td colspan="3"></td> <td colspan="3"> EXAMPLE: V M P L 0 N F 0 6 is a V7000 video machine with a 14" monitor, bill validator, chrome finish, touch screen monitor with buttons and a hopper. </td> </tr> </table>									Pos 1			Pos 7						V = Video			F = Bill Validator			V7200 / V8000 / V8500						C = Cash Cage™			V7200 / V8000 / V8500			Pos 2,3,4			B = Bill Validator / Cash Cage™			V7200 / V8000 / V8500			MPL = Multi Game Capable			P = Bill Validator / Progressive			V7200 / V8000 / V8500			POK = Poker (V5500)			E = Bill Validator / Cash Cage™ / Progressive			V7200 / V8000 / V8500						N = No Bill Validator / No Progressive / No Cash Cage™			V7200 / V8000 / V8500			Pos 5			0 = Non Progressive No Bill Validator			V7 20" / V7 w TB / V7 Bar			0 = Default			1 = Bill Validator No Progressive			V7 20" / V7 w TB / V7 Bar			A = V8500 14"			6 = Barcode Bill Non Progressive			V7 20" / V7 w TB / V7 Bar			B = V8500 17"									C = V8500 20" Horizontal									D = V8500 20" Vertical									3 = Video w/ Round top box									4 = V7000 w/ 20" monitor & top box									5 = V72 Slant 17" Monitor									6 = V72 Slant 12-button Deck									8 = V8 With Square Top									9 = V8 With Round Top																		Pos 6			Pos 8			<i>for Slants = Deck / Top Box Color</i> <i>for Uprights = Door Finish</i>			<i>Upright Cabinet Style</i> N = 14" Monitor (V7 / V72) Q = 20" Monitor (V7) M = V8000 20" upright L = V8000 LMAD W = Casino Style Top Box C = Chop Style Top Box R = Round Top Box X = Standard Cabinet <i>All Video Slant Top</i> F = Bar Top 0 = Slant Top / No Top Box S = Slant Top Standard Top Box D = Slant Top Round Top Box			Pos 9 1 = Touch Screen / Printer 2 = Touch Screen / Hopper 3 = Buttons / Printer 4 = Buttons / Hopper 5 = Touch Screen / Buttons / Printer 6 = Touch Screen / Buttons / Hopper 7 = Touch Screen / Buttons									<table border="1"> <tr> <td>Position 1</td> <td>Position 2</td> <td>Position 3</td> <td>Position 4</td> <td>Position 5</td> <td>Position 6</td> <td>Position 7</td> <td>Position 8</td> <td>Position 9</td> </tr> <tr> <td>V</td> <td>M</td> <td>P</td> <td>L</td> <td>0</td> <td>N</td> <td>F</td> <td>0</td> <td>6</td> </tr> </table>			Position 1	Position 2	Position 3	Position 4	Position 5	Position 6	Position 7	Position 8	Position 9	V	M	P	L	0	N	F	0	6							EXAMPLE: V M P L 0 N F 0 6 is a V7000 video machine with a 14" monitor, bill validator, chrome finish, touch screen monitor with buttons and a hopper.		
Pos 1			Pos 7																																																																																																																																																																																																																																												
V = Video			F = Bill Validator			V7200 / V8000 / V8500																																																																																																																																																																																																																																									
			C = Cash Cage™			V7200 / V8000 / V8500																																																																																																																																																																																																																																									
Pos 2,3,4			B = Bill Validator / Cash Cage™			V7200 / V8000 / V8500																																																																																																																																																																																																																																									
MPL = Multi Game Capable			P = Bill Validator / Progressive			V7200 / V8000 / V8500																																																																																																																																																																																																																																									
POK = Poker (V5500)			E = Bill Validator / Cash Cage™ / Progressive			V7200 / V8000 / V8500																																																																																																																																																																																																																																									
			N = No Bill Validator / No Progressive / No Cash Cage™			V7200 / V8000 / V8500																																																																																																																																																																																																																																									
Pos 5			0 = Non Progressive No Bill Validator			V7 20" / V7 w TB / V7 Bar																																																																																																																																																																																																																																									
0 = Default			1 = Bill Validator No Progressive			V7 20" / V7 w TB / V7 Bar																																																																																																																																																																																																																																									
A = V8500 14"			6 = Barcode Bill Non Progressive			V7 20" / V7 w TB / V7 Bar																																																																																																																																																																																																																																									
B = V8500 17"																																																																																																																																																																																																																																															
C = V8500 20" Horizontal																																																																																																																																																																																																																																															
D = V8500 20" Vertical																																																																																																																																																																																																																																															
3 = Video w/ Round top box																																																																																																																																																																																																																																															
4 = V7000 w/ 20" monitor & top box																																																																																																																																																																																																																																															
5 = V72 Slant 17" Monitor																																																																																																																																																																																																																																															
6 = V72 Slant 12-button Deck																																																																																																																																																																																																																																															
8 = V8 With Square Top																																																																																																																																																																																																																																															
9 = V8 With Round Top																																																																																																																																																																																																																																															
Pos 6			Pos 8			<i>for Slants = Deck / Top Box Color</i> <i>for Uprights = Door Finish</i>																																																																																																																																																																																																																																									
<i>Upright Cabinet Style</i> N = 14" Monitor (V7 / V72) Q = 20" Monitor (V7) M = V8000 20" upright L = V8000 LMAD W = Casino Style Top Box C = Chop Style Top Box R = Round Top Box X = Standard Cabinet <i>All Video Slant Top</i> F = Bar Top 0 = Slant Top / No Top Box S = Slant Top Standard Top Box D = Slant Top Round Top Box			Pos 9 1 = Touch Screen / Printer 2 = Touch Screen / Hopper 3 = Buttons / Printer 4 = Buttons / Hopper 5 = Touch Screen / Buttons / Printer 6 = Touch Screen / Buttons / Hopper 7 = Touch Screen / Buttons																																																																																																																																																																																																																																												
						<table border="1"> <tr> <td>Position 1</td> <td>Position 2</td> <td>Position 3</td> <td>Position 4</td> <td>Position 5</td> <td>Position 6</td> <td>Position 7</td> <td>Position 8</td> <td>Position 9</td> </tr> <tr> <td>V</td> <td>M</td> <td>P</td> <td>L</td> <td>0</td> <td>N</td> <td>F</td> <td>0</td> <td>6</td> </tr> </table>			Position 1	Position 2	Position 3	Position 4	Position 5	Position 6	Position 7	Position 8	Position 9	V	M	P	L	0	N	F	0	6																																																																																																																																																																																																																					
Position 1	Position 2	Position 3	Position 4	Position 5	Position 6	Position 7	Position 8	Position 9																																																																																																																																																																																																																																							
V	M	P	L	0	N	F	0	6																																																																																																																																																																																																																																							
						EXAMPLE: V M P L 0 N F 0 6 is a V7000 video machine with a 14" monitor, bill validator, chrome finish, touch screen monitor with buttons and a hopper.																																																																																																																																																																																																																																									

Glass and Decals

Pos 1	Pos 2	Pos 3	Pos 4	Pos 5	Pos 6	Pos 7	Pos 8	Pos 9																								
<div style="display: flex; justify-content: space-between;"> <div style="width: 45%;"> <table border="1" style="width: 100%; border-collapse: collapse;"> <tr><td>Pos 1 & 2</td></tr> <tr><td>DC = Roll the Dice® Top</td></tr> <tr><td>BR = Bell Ringer® Top</td></tr> </table> <table border="1" style="width: 100%; border-collapse: collapse;"> <tr><td>Pos 3</td></tr> <tr><td>0 = Default</td></tr> </table> <table border="1" style="width: 100%; border-collapse: collapse;"> <tr><td>Pos 4</td></tr> <tr><td>0 = Default</td></tr> </table> <table border="1" style="width: 100%; border-collapse: collapse;"> <tr><td>Pos 5</td></tr> <tr><td>1 = Gold Trim</td></tr> <tr><td>2 = Chrome Trim</td></tr> <tr><td>3 = Black Trim</td></tr> </table> </div> <div style="width: 45%; text-align: center;"> <table border="1" style="margin: 0 auto; border-collapse: collapse;"> <tr><td style="writing-mode: vertical-rl; transform: rotate(180deg);">Position 1</td></tr> <tr><td style="writing-mode: vertical-rl; transform: rotate(180deg);">Position 2</td></tr> <tr><td style="writing-mode: vertical-rl; transform: rotate(180deg);">Position 3</td></tr> <tr><td style="writing-mode: vertical-rl; transform: rotate(180deg);">Position 4</td></tr> <tr><td style="writing-mode: vertical-rl; transform: rotate(180deg);">Position 5</td></tr> <tr><td style="writing-mode: vertical-rl; transform: rotate(180deg);">Position 6</td></tr> <tr><td style="writing-mode: vertical-rl; transform: rotate(180deg);">Position 7</td></tr> <tr><td style="writing-mode: vertical-rl; transform: rotate(180deg);">Position 8</td></tr> <tr><td style="writing-mode: vertical-rl; transform: rotate(180deg);">Position 9</td></tr> </table> <p>EXAMPLE: B R 0 0 2 0 0 0 0 is a Bell Ringer™ Top Box with chrome trim.</p> </div> </div> <table border="1" style="width: 100%; border-collapse: collapse;"> <tr><td>Pos 6 & 7</td></tr> <tr><td>Refers to Face Finish, see Powdercoat list</td></tr> </table> <table border="1" style="width: 100%; border-collapse: collapse;"> <tr><td>Pos 8 & 9</td></tr> <tr><td>Refers to Laminate Finish, see Laminate Color list</td></tr> </table>									Pos 1 & 2	DC = Roll the Dice® Top	BR = Bell Ringer® Top	Pos 3	0 = Default	Pos 4	0 = Default	Pos 5	1 = Gold Trim	2 = Chrome Trim	3 = Black Trim	Position 1	Position 2	Position 3	Position 4	Position 5	Position 6	Position 7	Position 8	Position 9	Pos 6 & 7	Refers to Face Finish, see Powdercoat list	Pos 8 & 9	Refers to Laminate Finish, see Laminate Color list
Pos 1 & 2																																
DC = Roll the Dice® Top																																
BR = Bell Ringer® Top																																
Pos 3																																
0 = Default																																
Pos 4																																
0 = Default																																
Pos 5																																
1 = Gold Trim																																
2 = Chrome Trim																																
3 = Black Trim																																
Position 1																																
Position 2																																
Position 3																																
Position 4																																
Position 5																																
Position 6																																
Position 7																																
Position 8																																
Position 9																																
Pos 6 & 7																																
Refers to Face Finish, see Powdercoat list																																
Pos 8 & 9																																
Refers to Laminate Finish, see Laminate Color list																																

The slant machine Feature Top Box Model Number convention refers to the specialty machines produced by Bally Gaming that use a slant reel machine as a platform, and have a "feature" top box. This numbering convention refers only to the top box, however. These specialty machines are sold as a unit. The top box is not available separately.

Top Boxes

This section shows the available top boxes for Bally machines. This section was included because it is not possible to show every configuration for each machine model. The top boxes and decal configurations shown in the Machine Image section are general representations but may be assembled differently due to top box selection, or a decal variation. The configurations shown in the Video and Slot Machine sections should not be considered as the only option. "Extended Top Box" refers to top boxes configured with the Player Tracking system. This system usually includes a bracket, keypad, cardreader, and display, as shown here, with a decal overlay for the bracket or faceplate.

Machine configuration variations are indicated in the Machine Model Number. Decal variations may be due to machine configuration variations, jurisdiction restrictions, or game-specific requirements. Refer to the tables in the front of this module for model-specific decal options. A Bally Gaming Customer Service Representative can assist with information not listed here (telephone, fax, and address information is located in the front inside and back cover of this module).

Top Boxes for Slant Machines

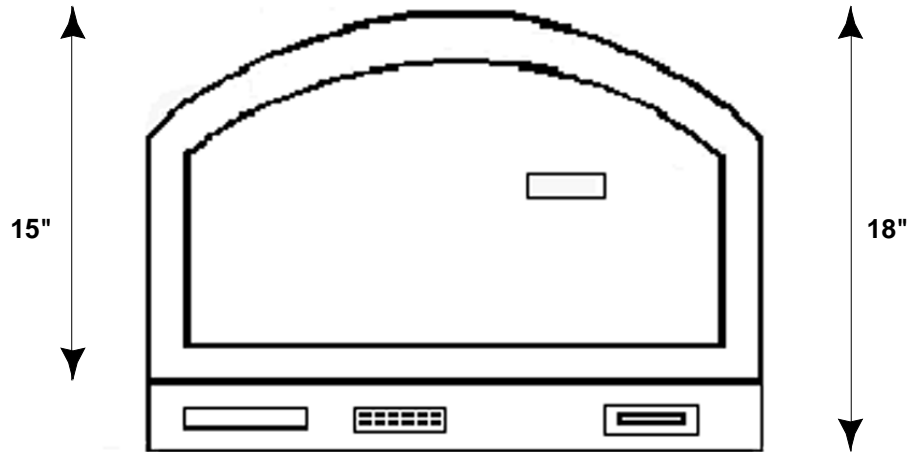

"Slant Round Top" or "Radius" Top Box

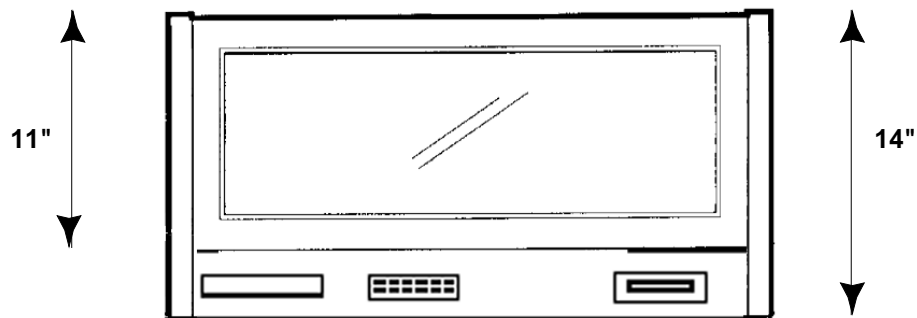

Standard Slant Top Box

NOTE: Measurements are not exact but are intended to provide a guide to differentiate between models. Machines with "extended" top boxes that are Player Tracking-ready will be 2.5" - 3.25" taller than top boxes without this feature.

Glass and Decals

**Top Boxes for
Upright Reel
Machines**

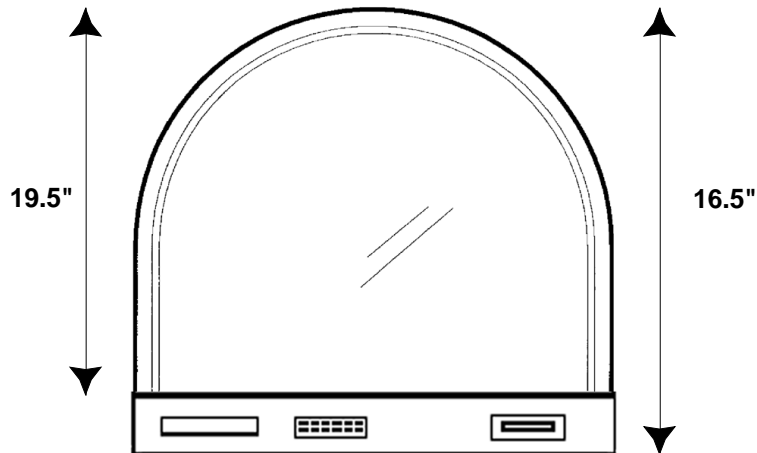

**“Round Top” Top Box
(R6 style cabinet)**

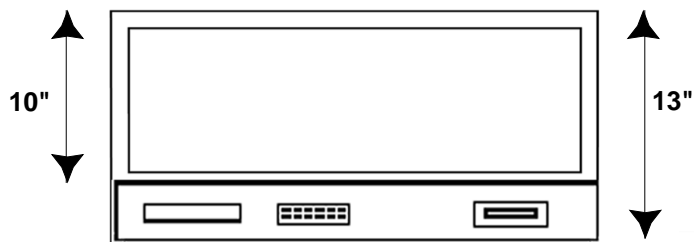

**“Crop or Chop Top” Top Box
(C6 style cabinet)**

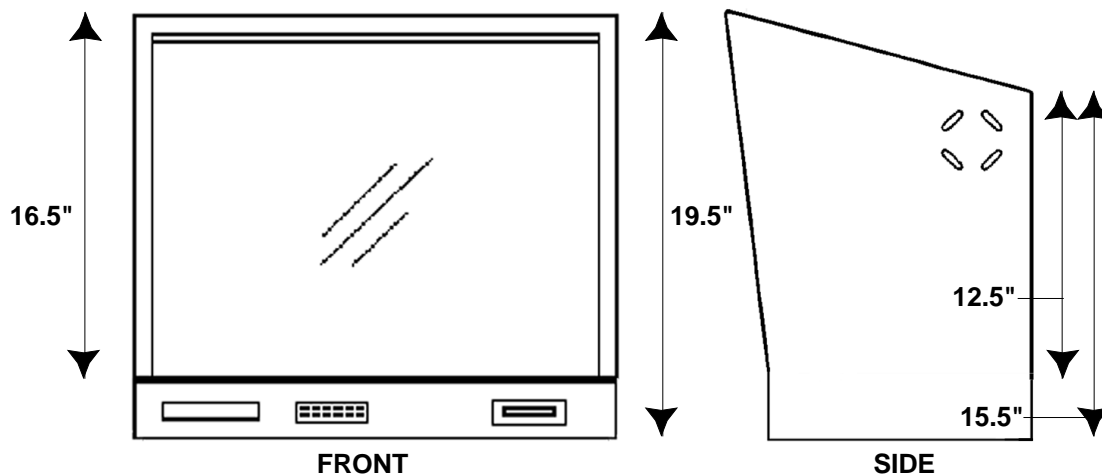

**“Casino style” Top Box (The same dimensions apply to a Bullnose Top Box.)
(W6 style cabinet)**

NOTE: Measurements are not exact but are intended as a guide to differentiate between models. Machines with “extended” top boxes that are Player Tracking-ready will be 2.5” - 3.25” taller than top boxes without this feature.

Glass Examples

This section shows decal arrangements on common reel glass for machines with and without bill validators. (Note the difference in reel glass lengths due to bill validator configuration.) Also shown are Feature/Top Box glass and Display/Belly glass examples. It is not possible to show every glass configuration for each machine, although two configurations for the S6000 are shown in the Slot Machine Image section. The Feature/Top Box glass and Display/Belly glass have been included to show the decal arrangement for Package Games.
Note: A “D” in the part number prefix indicates a decal, a “G” in the part number prefix indicates a glass piece.

G606 is the only reel glass for slant machines. Note: The D310 on G606 is not the same shape and size as the D310 on the G593. Some decal series have different sizes within the series; the most common examples are the D150 and the D310 series. Additionally, oddly sized and rare decals are listed in the D200 series. The D200 series is also the series name for the Player Tracking Overlay Decals. For assistance regarding the particular decal, please call your Bally Customer Service Representative. The address, fax and telephone information are listed within the front and back covers of this module.

G606 for Slant Top Slot Reels

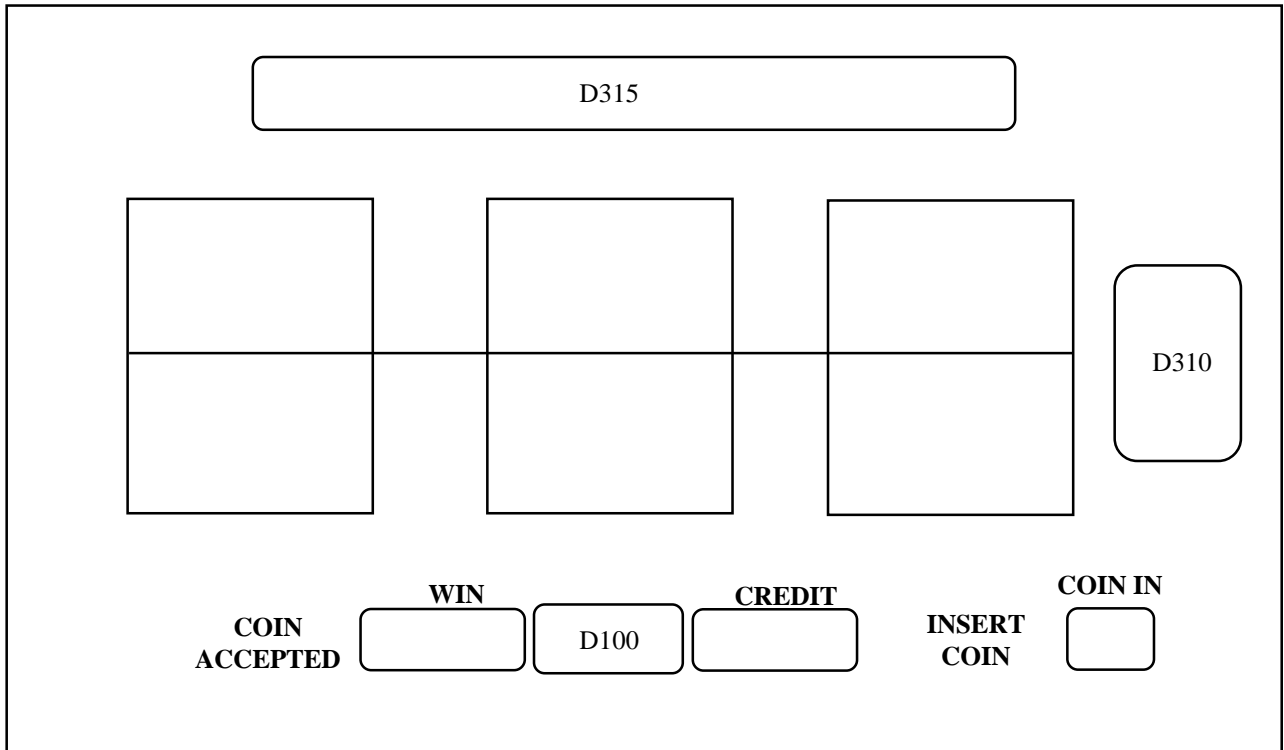

G606 SLANT REEL GLASS

Glass and Decals

The G593 is used for the S5500 without a bill validator, and the S6000 where bill validator access is through the deck. The arrow shown below does not appear on the glass configured for the S5500 without a bill validator.

G593 for Upright S5500 and S6000 Reels

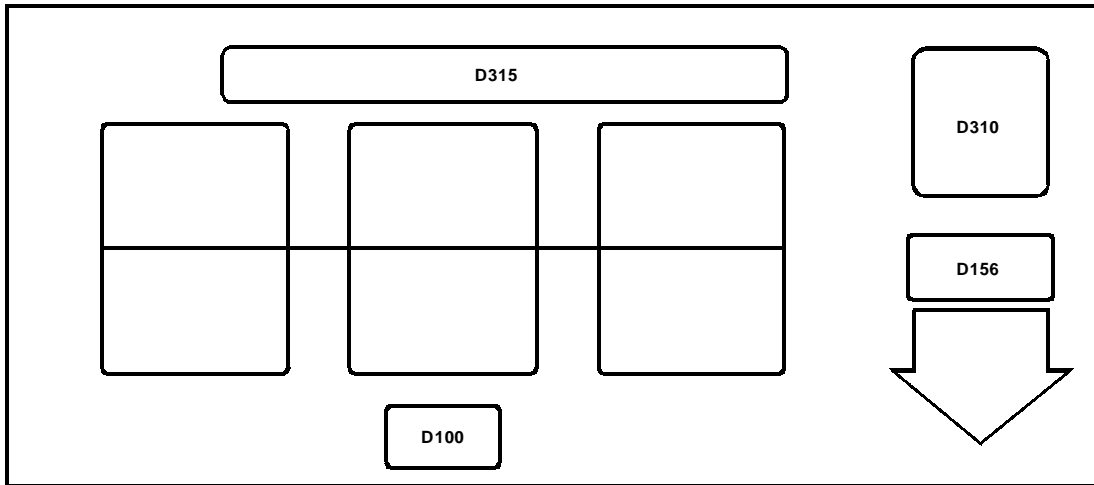

G593 REEL GLASS

The G594 reel glass is used for the S5500 configured with a bill validator that mounts next to the reels.

G594 for Upright S5500 and S6000 Reels

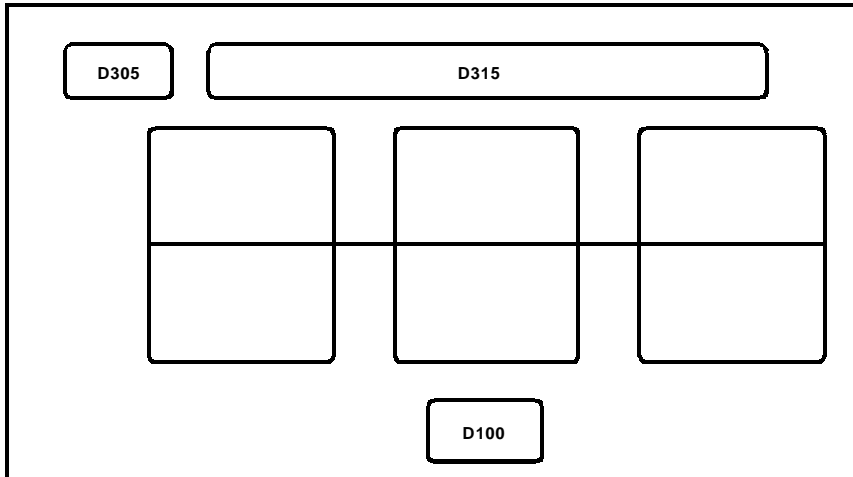

G594 REEL GLASS

The G705 is used for the S6000 configured for Cash Cage™ or SCI® Smart Card.

G705 for Upright S6000 Reels with Cash Cage™

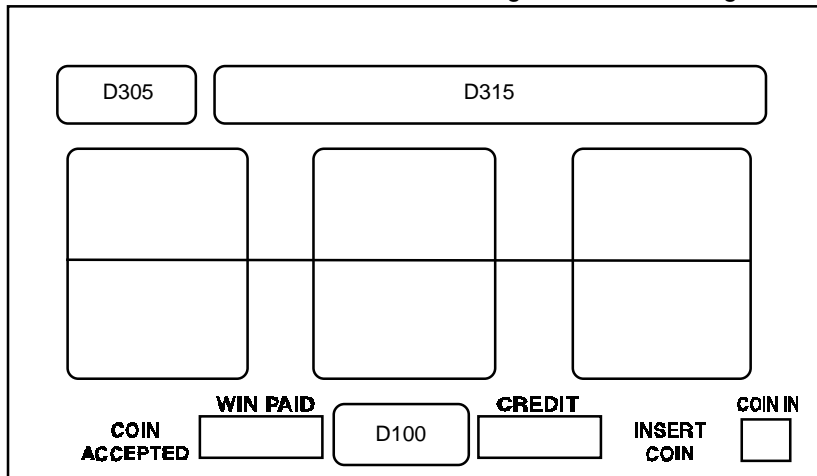

G705 CASH CAGE

G612 Feature Glass for V7000 Upright - Standard Video Top Box Configuration

NOTE: The G612 is referred to as "midpanel glass" on the V7000 with 20" monitor and top box.



G612 STANDARD VIDEO FEATURE GLASS

G612 Feature Glass for V7000 Upright - Package Game Configuration

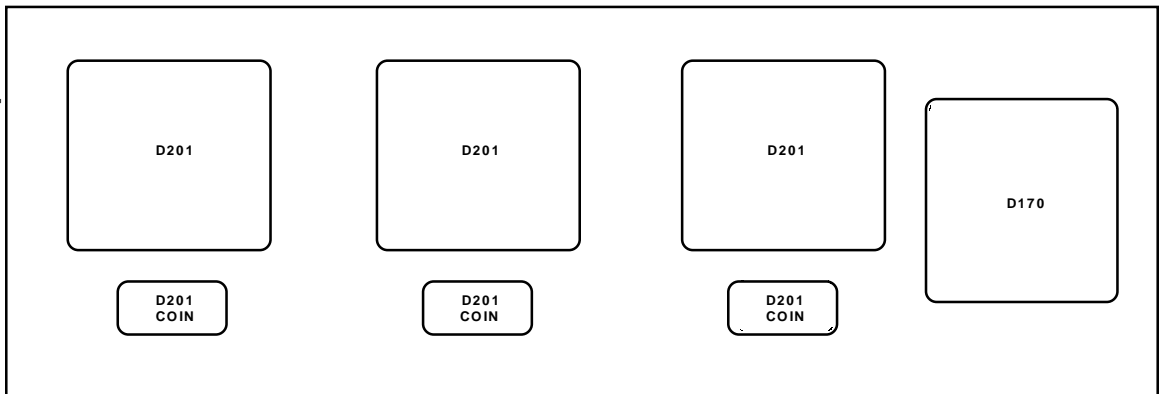

G612: V7200 - FEATURE GLASS for PACKAGE GAMES

G591 Belly Glass for V7000 Upright - Package Game Configuration

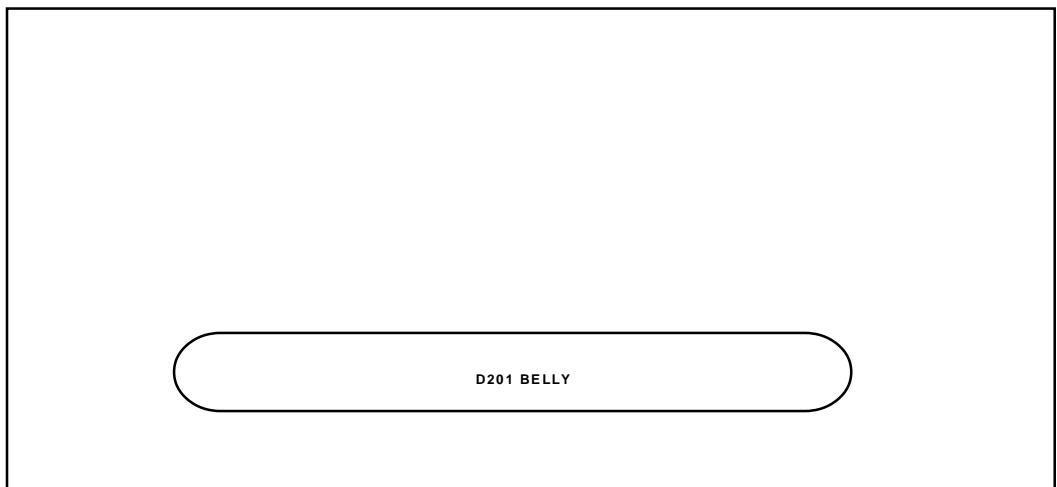

G591 BELLY GLASS for PACKAGE GAMES

Glass and Decals

Slot Machine Images

This section shows common model-specific decal configurations. There may be variations in decal arrangement because of jurisdiction restrictions, game specifications, and machine components. Alternate bill validator configurations are identified in pull-outs. Please refer to the tables at the front of this module for glass and decal options, or contact a Bally Gaming Customer Service representative (telephone and fax numbers are located in the inside front and back covers of this module). **Note: A “D” in the part number prefix indicates a decal, a “G” in the part number prefix indicates a glass piece.**

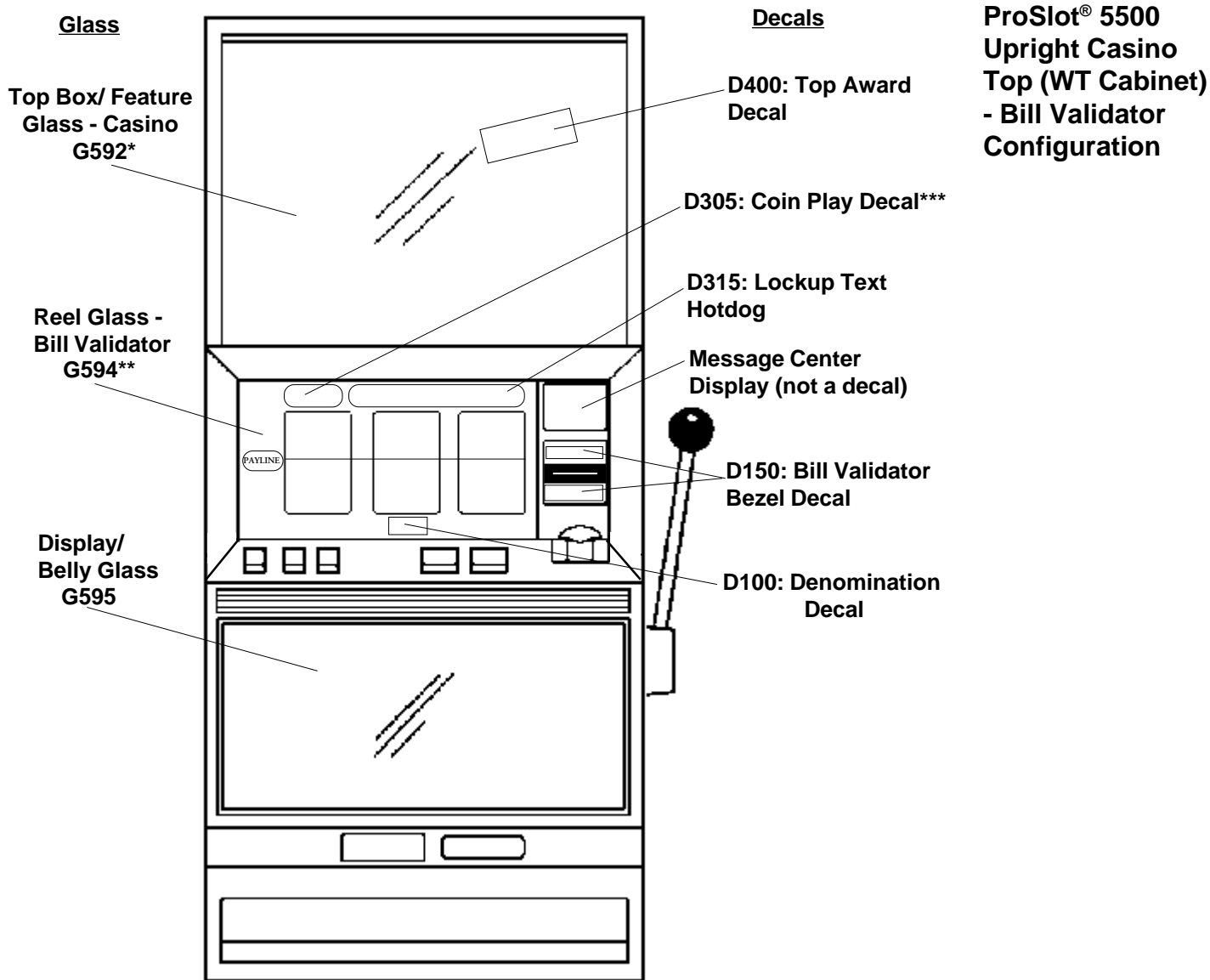

*The glass prefix for the Chop Top (C6) is G600; the Round Top Box (R6) it is G609.

** The reel glass prefix for reel glass with no bill validator is G593.

***Use D310 (large Coin Play Decal) and D156 (Bill Value Range Decal) with G593. Use D305 (mini-hotdog Coin Play Decal) with G594 (shown here).

A Player Tracking System is available for this machine but is not shown here. The box containing the keypad, display and cardreader would be located below the top box of this machine. Player Tracking Custom Overlay Decal prefix: D200; otherwise the prefix is M-R0617.

**ProSlot® 6000
Upright Casino
Top (WT Cabinet)
- Bill Validator
Configuration**

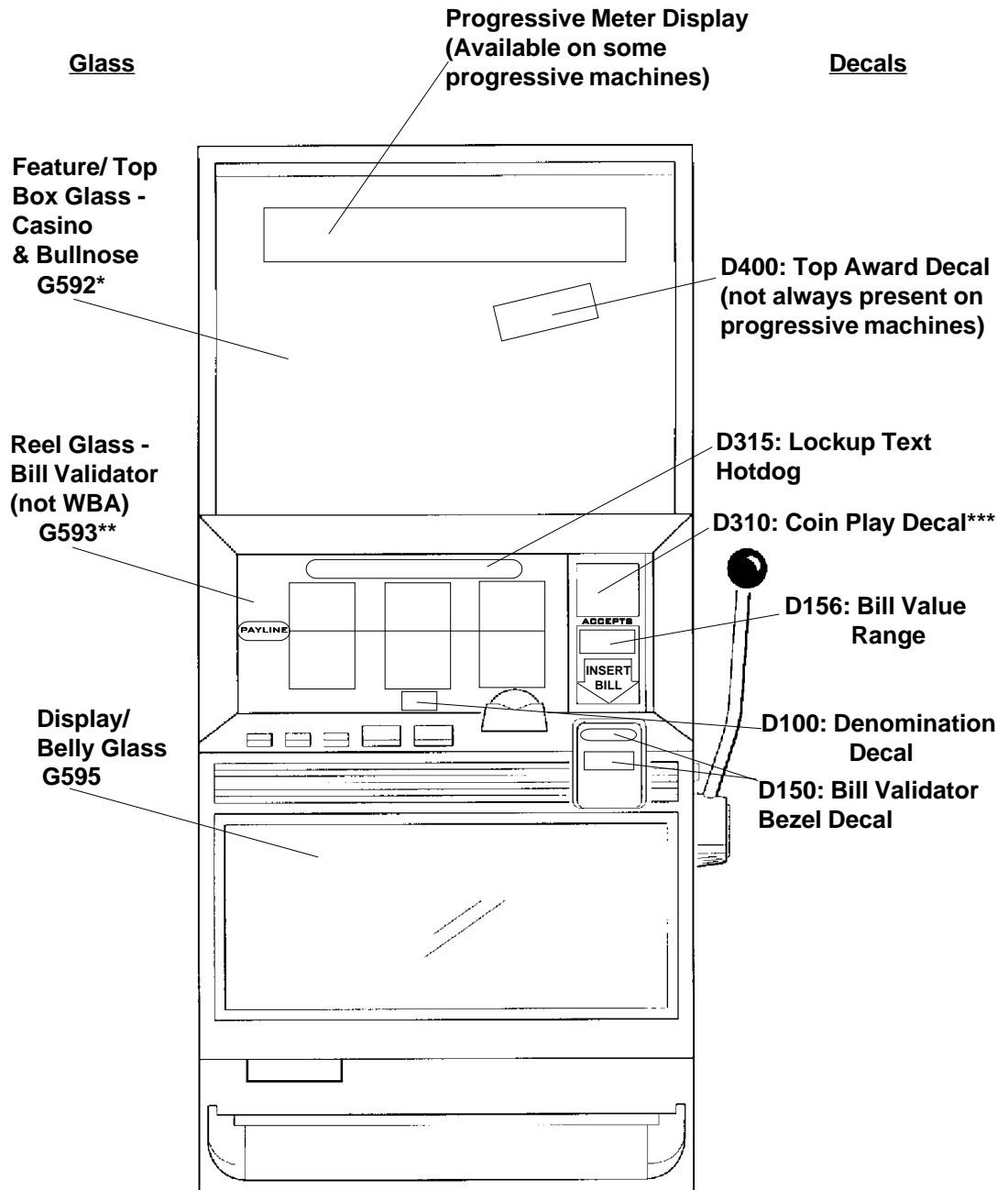

*The glass prefix for the Chop Top (C6) is G600; the Round Top Box (R6) it is G609.

**The reel glass prefix for reel glass with a WBA bill validator is G593; for Cash Cage™ it is G705.

***Use D310 (large Coin Play Decal) and D156 (Bill Value Range Decal) with G593 (shown here). Use D305 (mini-hotdog Coin Play Decal) with G705.

A Player Tracking System is available for this machine but is not shown here. The box containing the keypad, display and cardreader would be located below the top box of this machine. Player Tracking Custom Overlay Decal prefix: D200; otherwise the prefix is M-R0617.

Glass and Decals

ProSlot® 6000
Upright Round
Top (WR Cabinet)
- Cash Cage™
Configuration

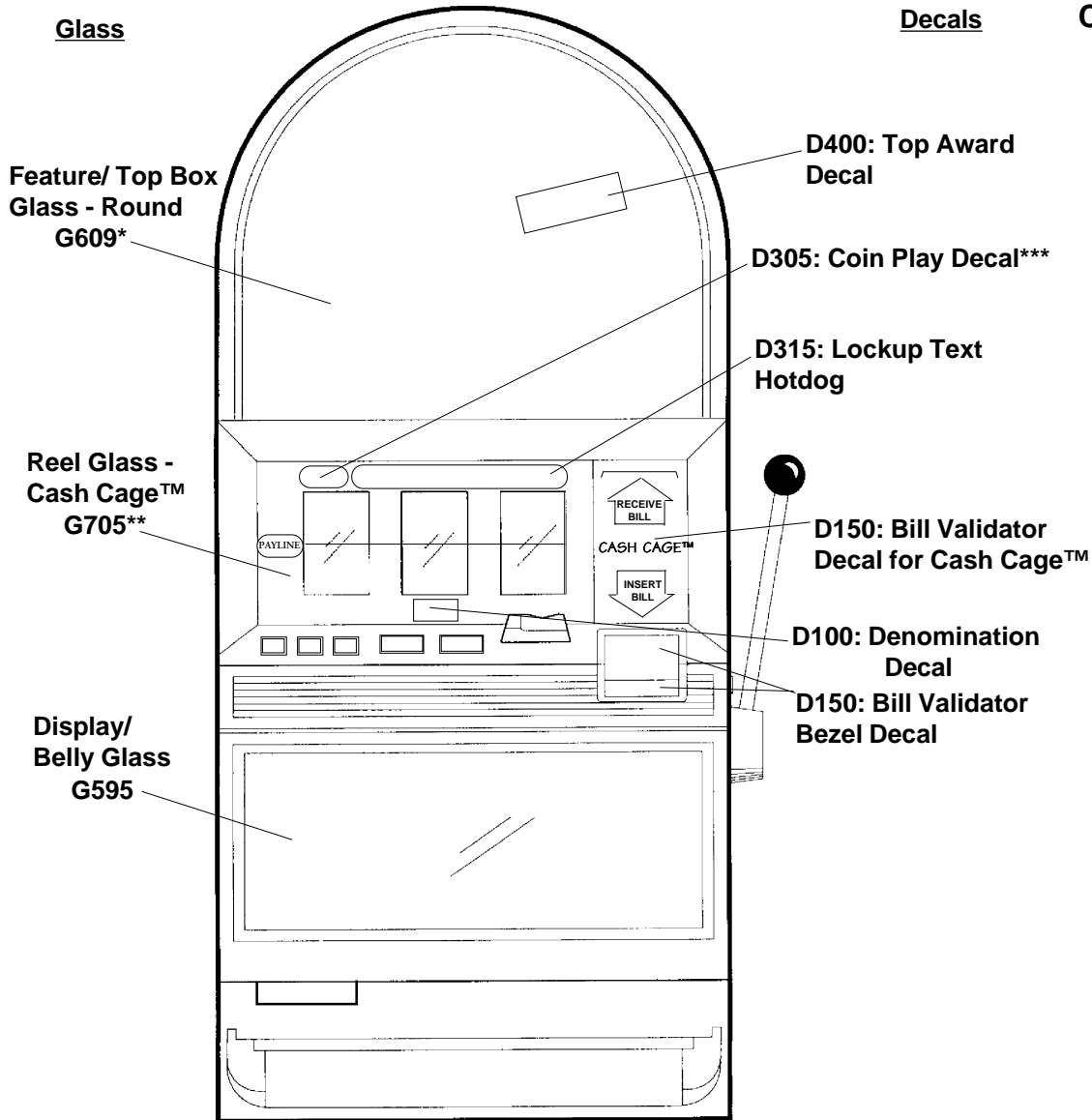

*The glass prefix for the Casino Top Box (W6) and Bullnose is G592; the Chop Top (C6) is G600.

** The reel glass prefix for reel glass with a WBA bill validator is G593.

***Use D310 (large Coin Play Decal) and D156 (Bill Value Range Decal) with G593. Use D305 (mini-hotdog Coin Play Decal) G705 (shown here).

A Player Tracking System is available for this machine but is not shown here. The box containing the keypad, display and cardreader would be located below the top box of this machine. Player Tracking Custom Overlay Decal prefix: D200; otherwise the prefix is M-R0617.

**ProSlant®
5500/6000*
Round Top**

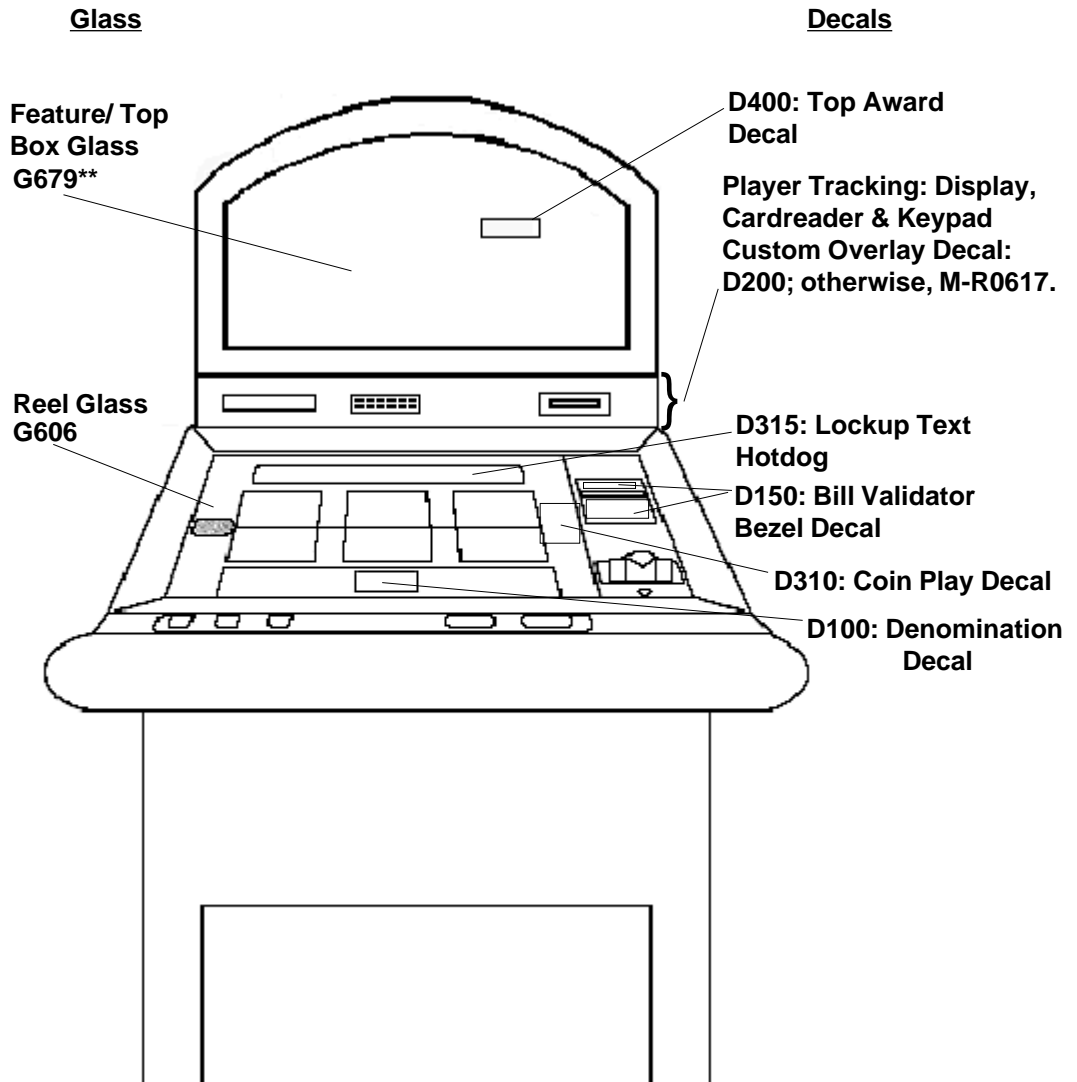

***NOTE:** The differences between the S5500 and S6000 are not significant with respect to the glass and decal specifications. For S6000 slants with Cash Cage™, the Cash Cage™ indicator decal (D150 prefix series) is located within the coin tray (not shown).

****The glass prefix for a Standard Slant Top Box is G605.**

Glass and Decals

Bell Ringer® -
S5500/S6000
Slant Platform
with Bell Feature
Top Box

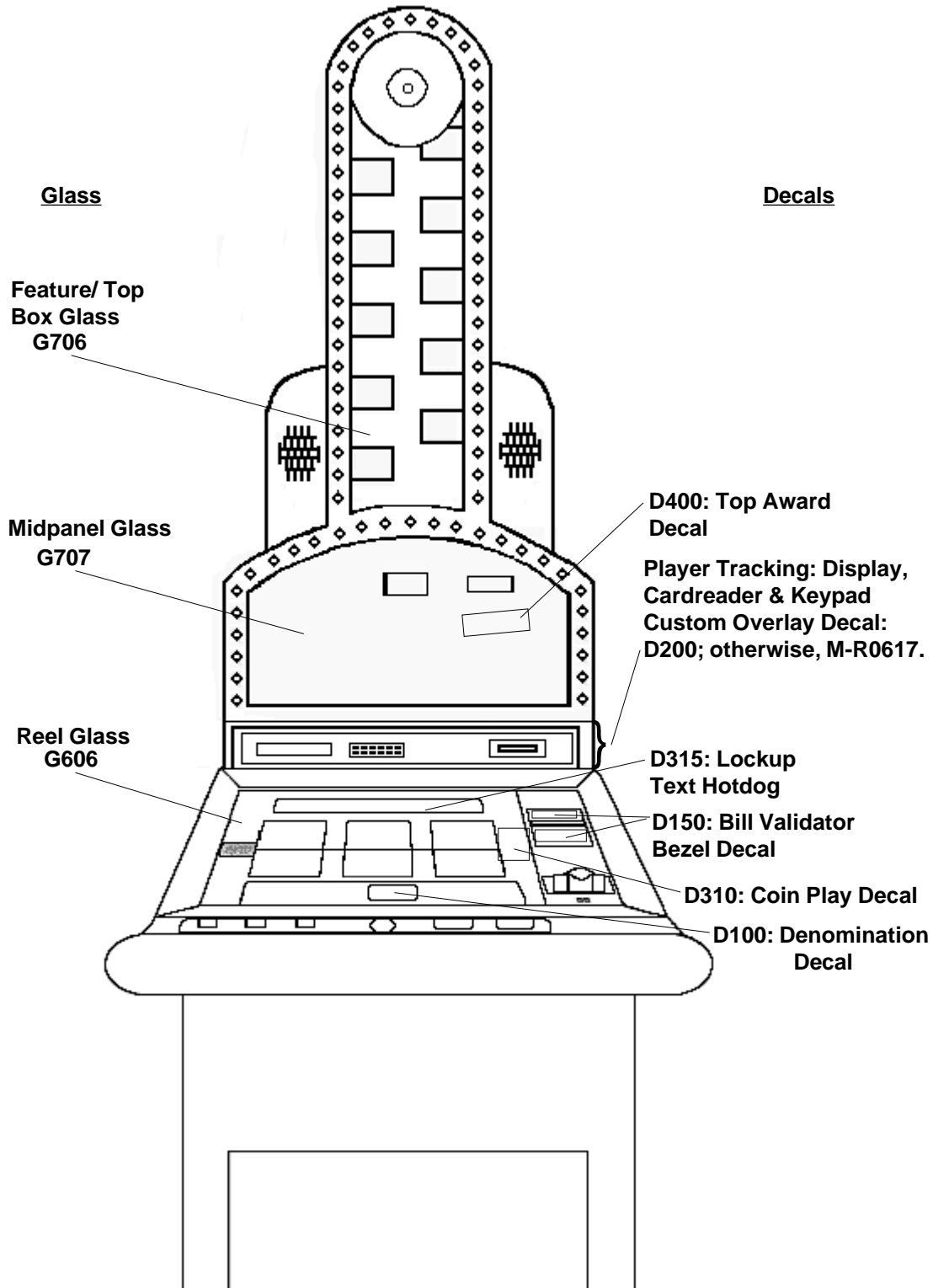

**Roll the Dice® -
S5500/S6000
Slant Platform
with Dice
Feature Top Box**

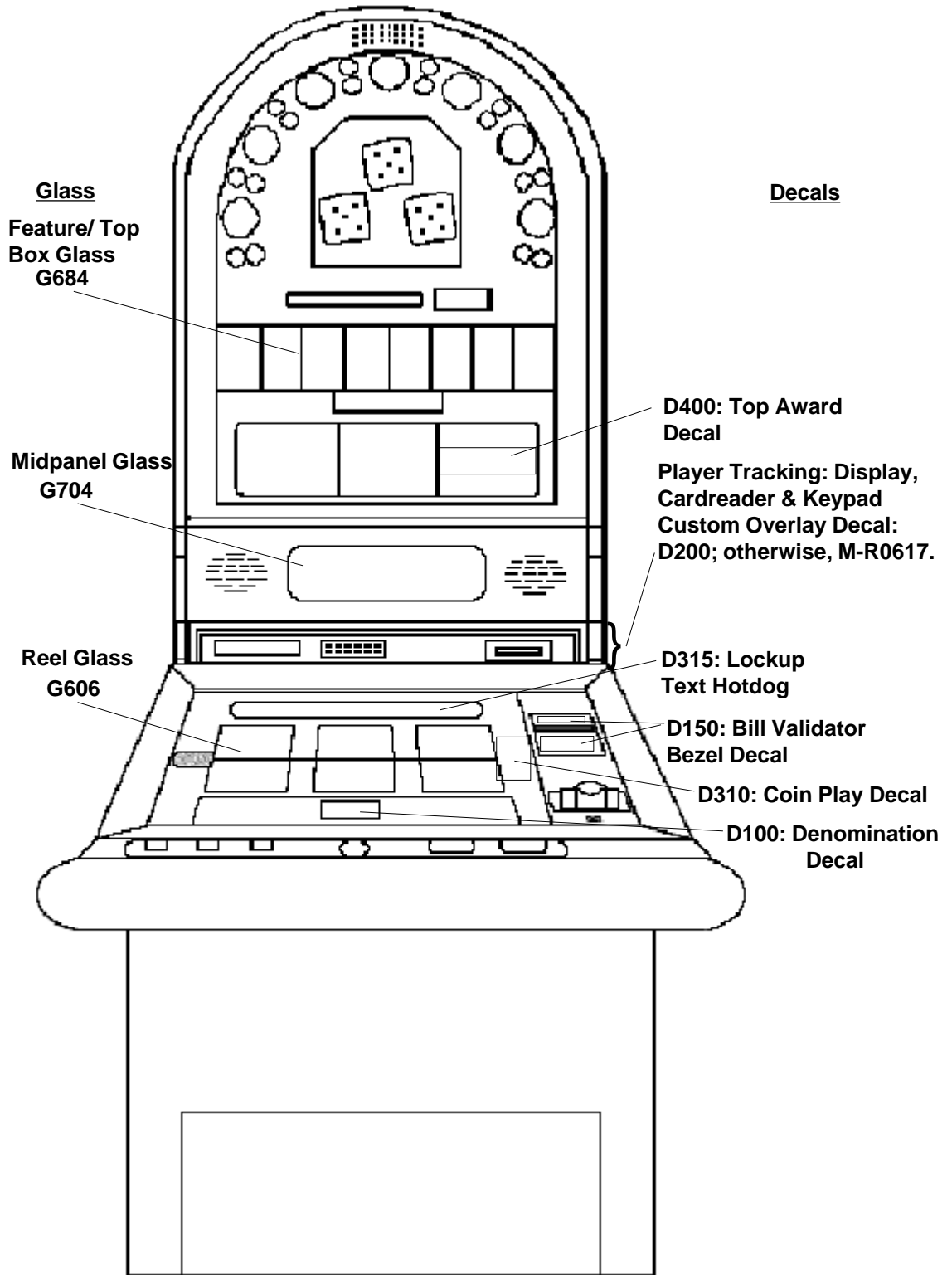

Glass and Decals

Betty Boop™ -
S6000 Slant
Platform with High
Profile Feature Top
Box

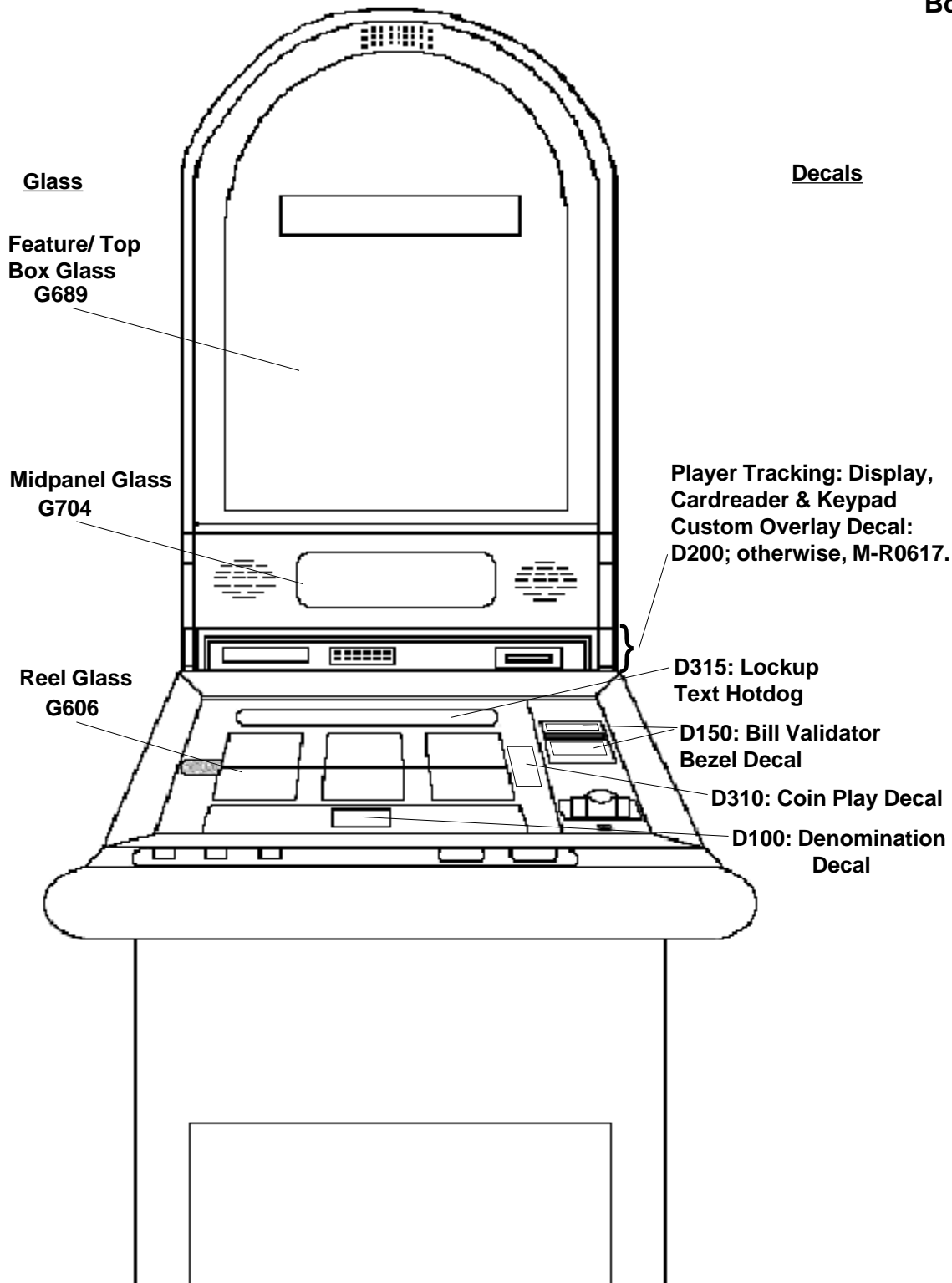

© 1999 King Features Syndicate, Inc. / Fleischer Studios, Inc.™The Hearst Corporation/ Fleischer Studios Inc.

Video Machine Images

Game Maker® 7000 Bartop

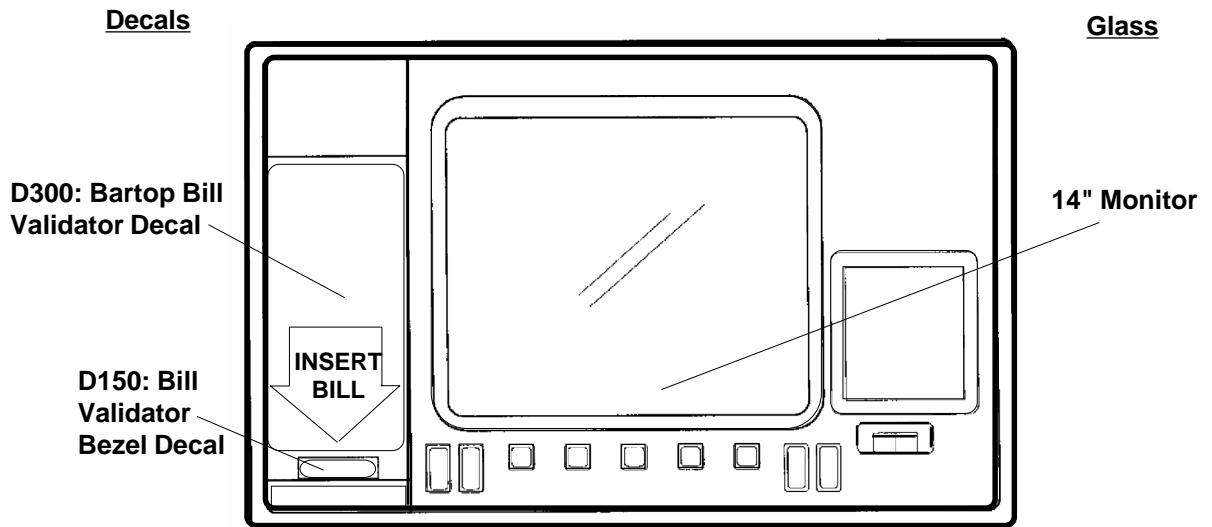

Glass and Decals

Decals for the CBV / GPT Bill Validator Configuration

**Game Maker®
7000 with
14" Monitor -
Package Game*
Configuration**

**D157: Bill Validator
Decal for the V7000**

**D100: Denomination
Decal**

**D156: Bill Value
Range Decal**

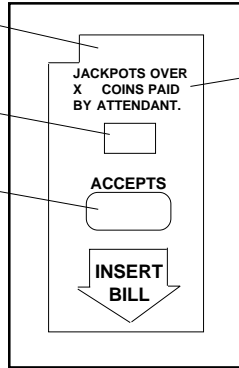

**Example Text
(included on D157)**

Glass

Decals

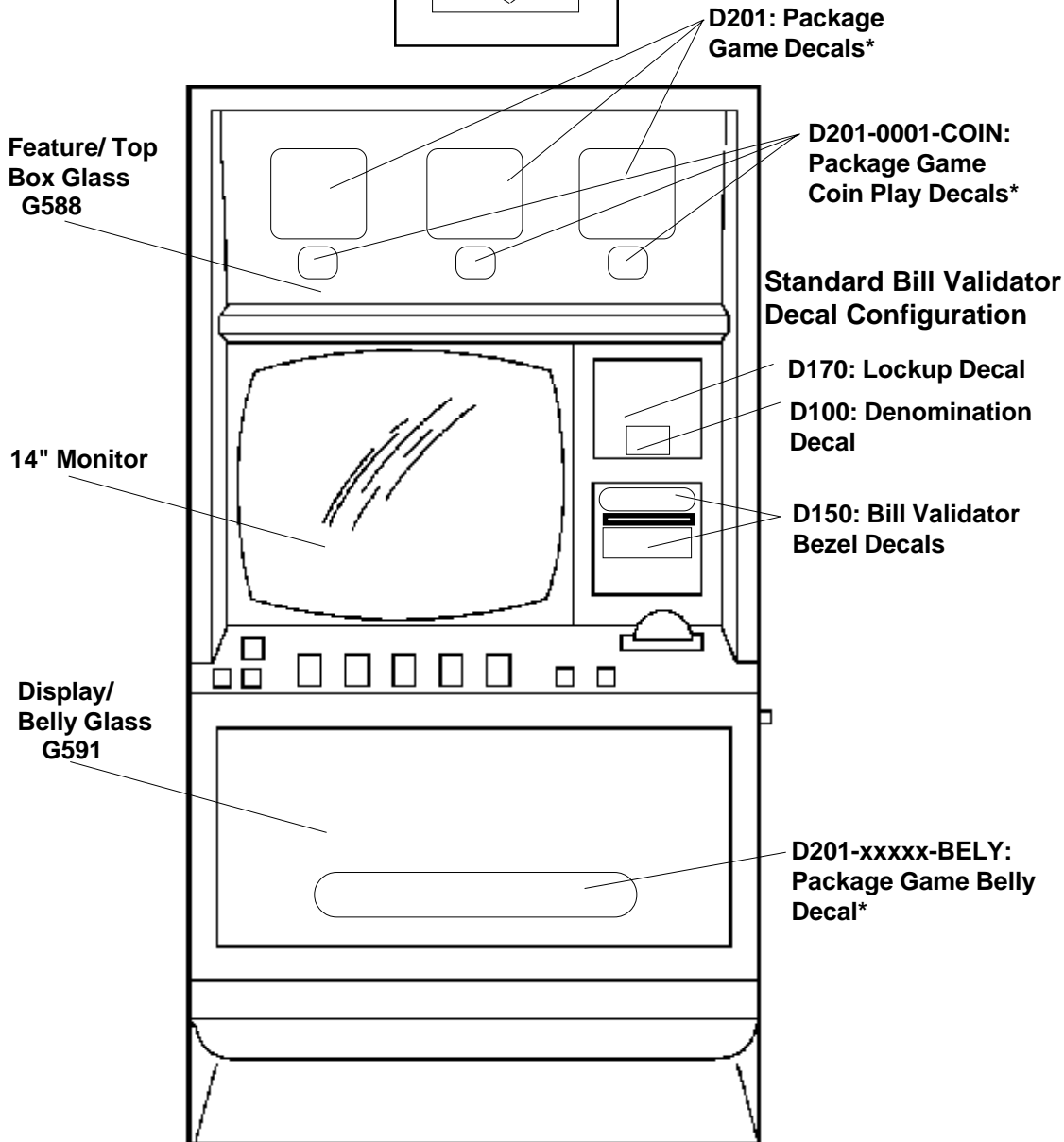

*Package Games have been developed for the V7000 and V7200 product lines. Three sets of decals are required for this game configuration: Package Game (D201), Package Game Coin (D201-00001-COIN), and Package Game Belly (D201-xxxxx-BELY).

Player Tracking is also available for this machine. Decal Overlay: M-R0617; or custom: D200

**Game Maker®
7200 Upright
with 14" Monitor
- Standard Bill
Validator and
Cash Cage™
Formats**

**Standard Bill Validator
Decal Configuration**

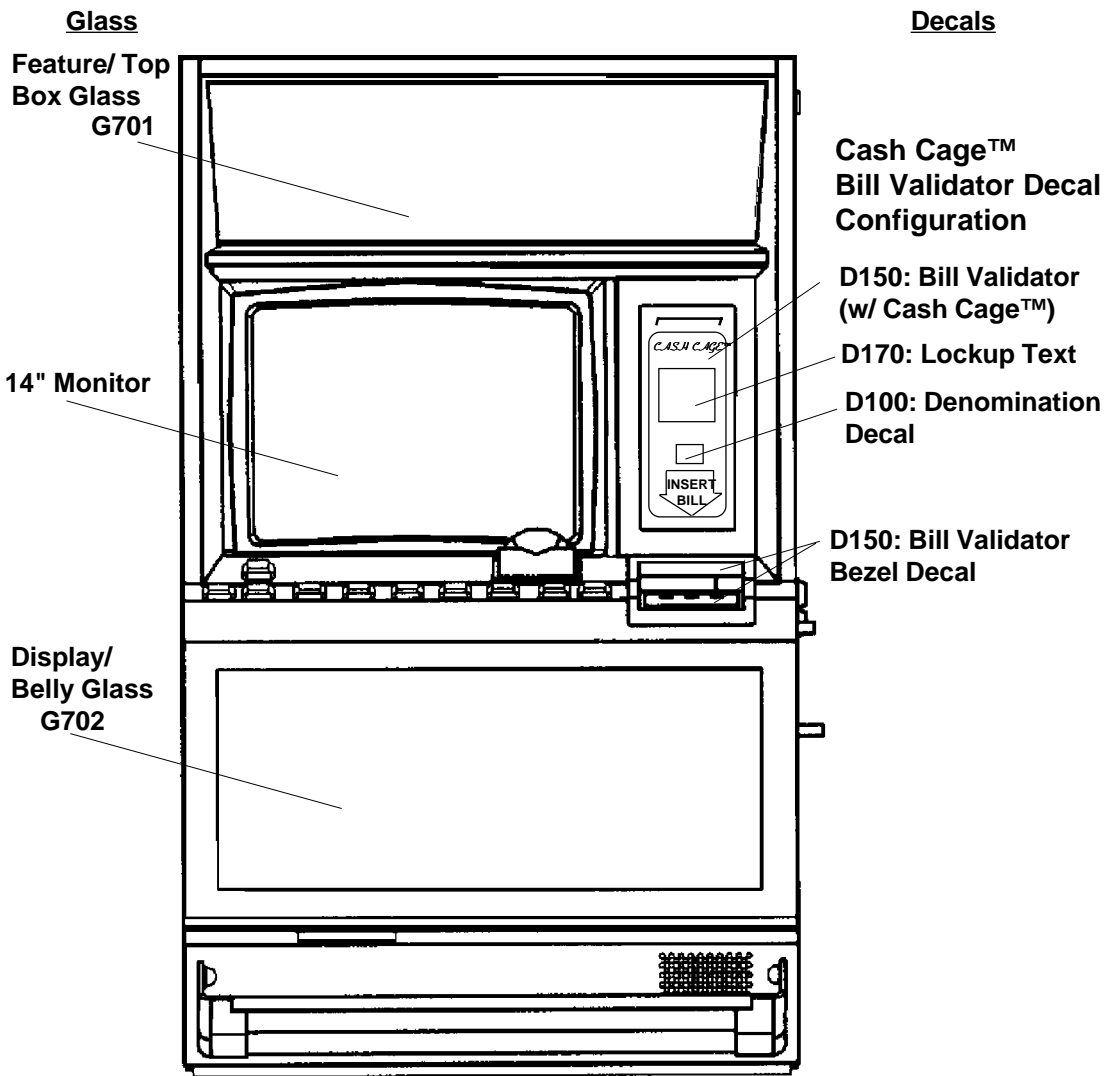
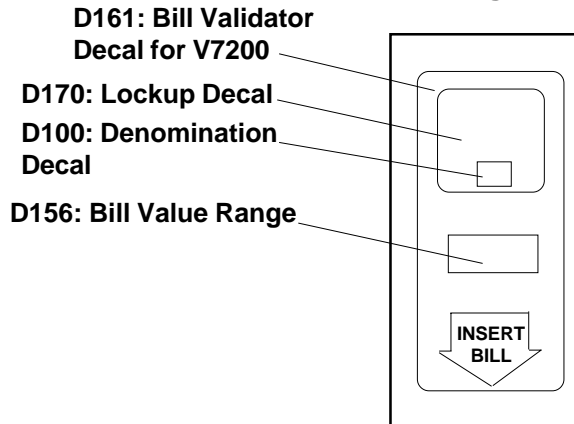

A Player Tracking System is available for this machine but is not shown here. The box containing the keypad, display and cardreader would be located on top of this machine. Player Tracking Custom Overlay Decal prefix: D200; otherwise the prefix is M-R0617.

Glass and Decals

Game Maker®
7000/7200* Slant -
Standard Top Box

Glass

Decals

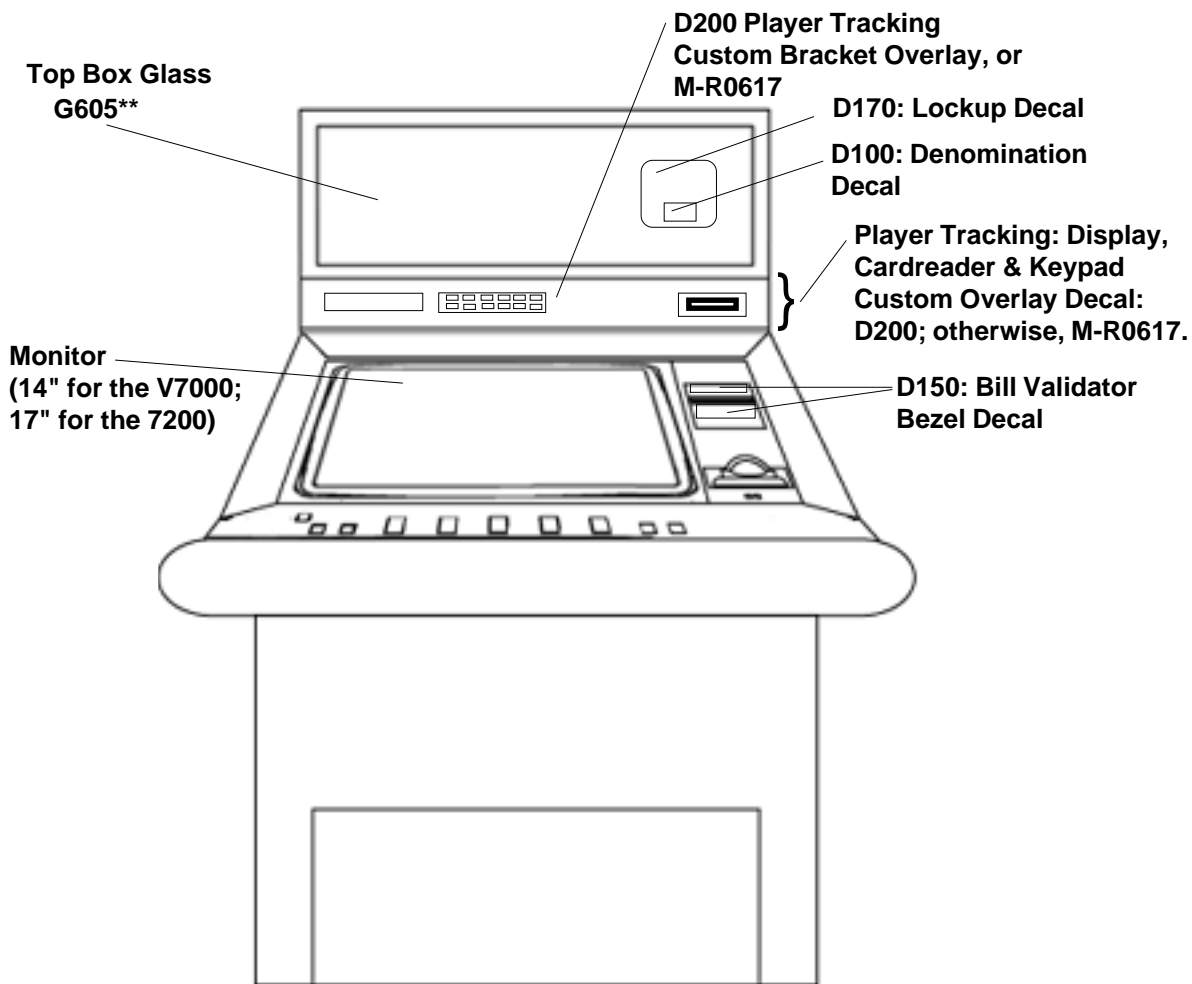

***NOTE:** The differences between the V7000 and V7200 are not significant with respect to the glass and decal specifications. For V7200 slants with Cash Cage™, the Cash Cage™ indicator decal (D150 prefix series) is located within the coin tray (not shown).

****The glass prefix for a "Round Top" or "Radius" Top Box is G679.**

**Game Maker®
7000 with
20" Monitor**

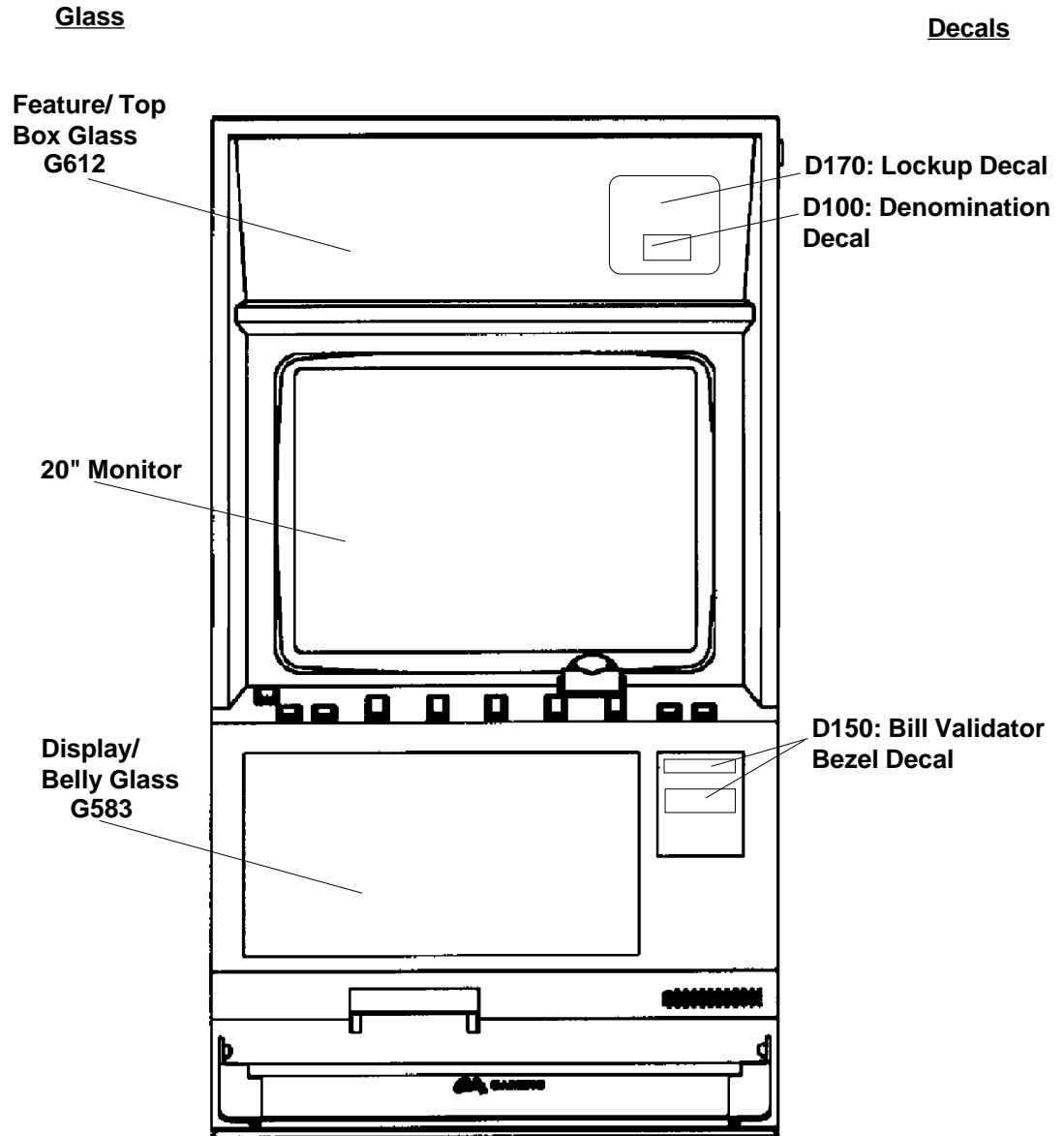

A Player Tracking System is available for this machine but is not shown here. The box containing the keypad, display and cardreader would be located on top of this machine. Player Tracking Custom Overlay Decal prefix: D200; otherwise the prefix is M-R0617.

Glass and Decals

V7000 with
20" Monitor and
Top Box

Glass

Decals

Feature/ Top
Box Glass
G592

D200 Top Award,
Bonus Game, and
"Play Up To" Decals
(They are D200 series
decals because they're
oversized)

Top Award

Bonus Game

Player Tracking:
Display, & Cardreader
(Keypad not shown)
Decal Overlay:
M-R0617, or
if custom: D200

Midpanel Glass
G612

Play Up To

D170: Lockup Decal

D100: Denomination Decal

20" Monitor

Display/
Belly Glass
G583

D150: Bill Validator
Bezel Decal

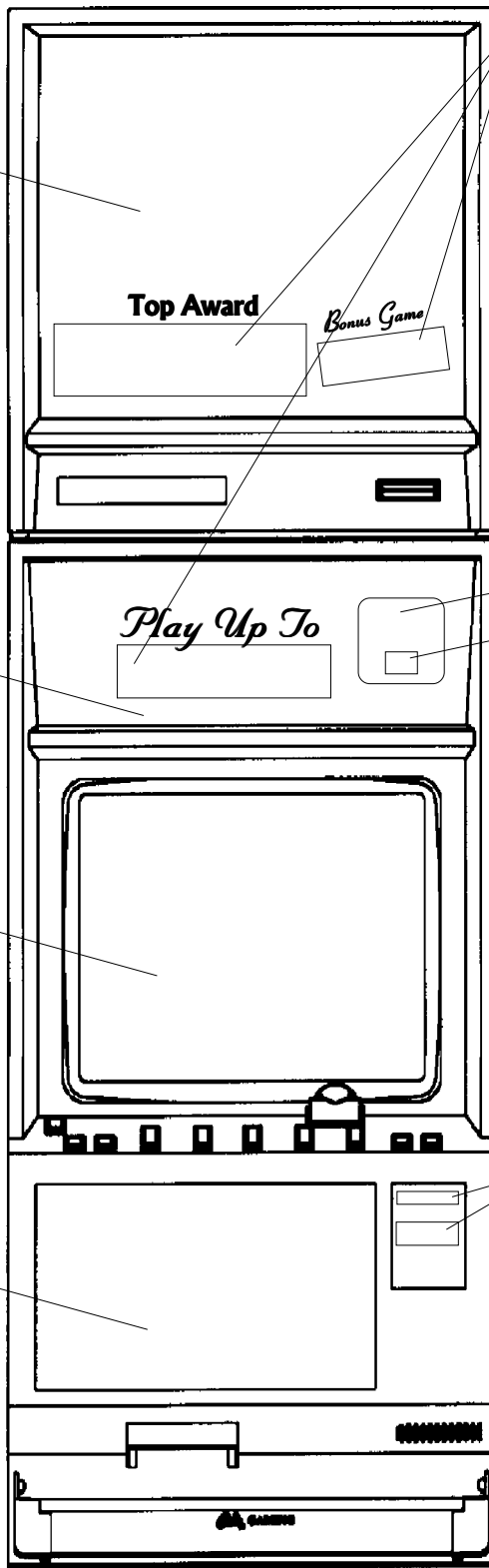

**Game Magic®
8000**

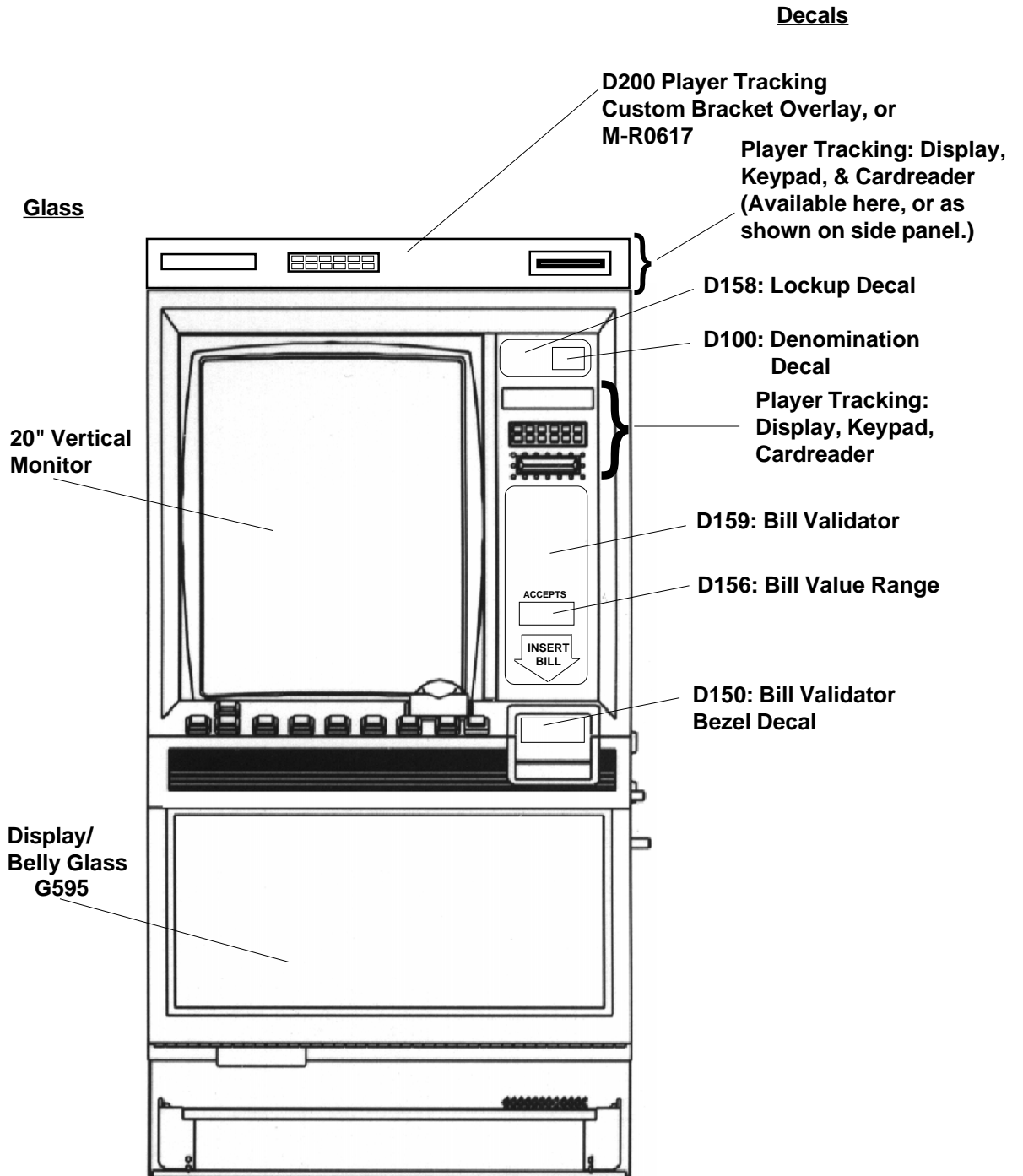

Glass and Decals

Let's Make a Deal™ -
V8000 with Top Box

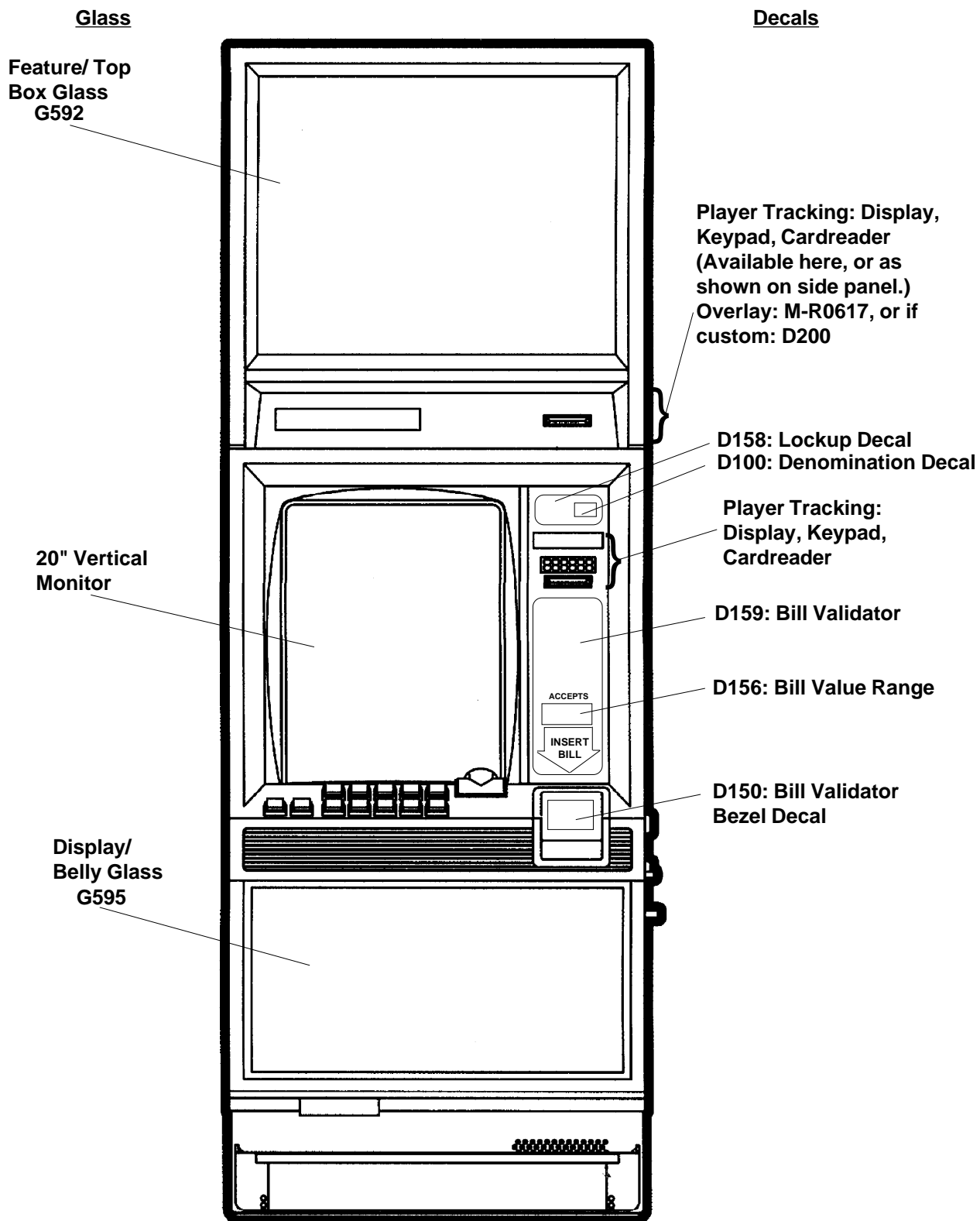

Let's Make a Deal™ is a trademark of Hatos-Hall Productions and is used under license.



Slot Machine Express Model Theme and Art Form

Use this table to order glass and reel tape for express machine conversions. Your Bally Customer Service representative can assist you in your selection.

Effective October 1, 1999 - April 1, 2000

EXPRESS MODELS				
	GAME THEME	ART FORM	COINS	PERCENTAGE
1	Blazing 7's Standalone Progressive	BL7-5026	3	92.83 - 95.45
2	Blazing 7's With Double Jackpot	DM7-5001	2	86.46 - 95.00
3	Blazing 7's Double Jackpot	BLD-5001	3	89.03 - 96.57
4	Triple Blazing 7's With Double Symbol	DM7-5002	3	83.66 - 96.84
5	Triple Blazing 7's With Double Symbols 5-Line	DM7-5009	5L	83.09 - 93.94
6	4 th Coin Blazing 7's	MJ7-5008	4	88.41 - 94.72
7	Double Jackpot Black & White Triple 7's	DM7-5016	5L	83.09 - 93.94
8	Double JP/B&W Triple 7's	DM7-5010	2	86.45 - 98.02
9	Double Jackpot Black & White Triple 7's	DM7-5011	3	86.58 - 98.00
10	Roaring 20's With Sound	RTW-5001	2	79.53 - 97.21
11	Black & White 5X	DC5-5002	2	84.49 - 96.72
12	Question Mark Game	RTW-5002	3	93.56 - 97.20
13	5X 10X Game	DCM-5058	2	83.50 - 96.92
14	5X 10X Game	DCM-9057	3	83.68 - 96.93
15	Blazing 7's (7 Times Pay)	DCM-5052	3	83.53 - 97.11
16	Blazing 7's (7 Times Pay)	DCM-5053	2	83.20 - 96.78
17	Five & Dime	FDM-5001	3	83.32 - 96.94
18	Five & Dime	FDM-5002	2	83.63 - 96.92
19	Pool Sharks	DAP-5001	2	89.56 - 95.50
20	Y2K	RTW-5009	3	89.09 - 97.21
21	Swing Time	RTW-5004	3	88
22	Swing Time	RTW-5005	3	90
23	Swing Time	RTW-5006	3	92
24	Swing Time	RTW-5007	3	94
25	Swing Time	RTW-5008	3	96

**For Customer Service and information:
+1-702-896-7772 Outside the U.S.
1-877-GO-BALLY (877) 462-2559 in the U.S. and Canada
896-7772 in Las Vegas
FAX: +1-702-896-7710
or visit our website at <http://www.ballygaming.com>**