

Game Maker-7200™ Upright
Cabinet Signal
CBL-30258-0001

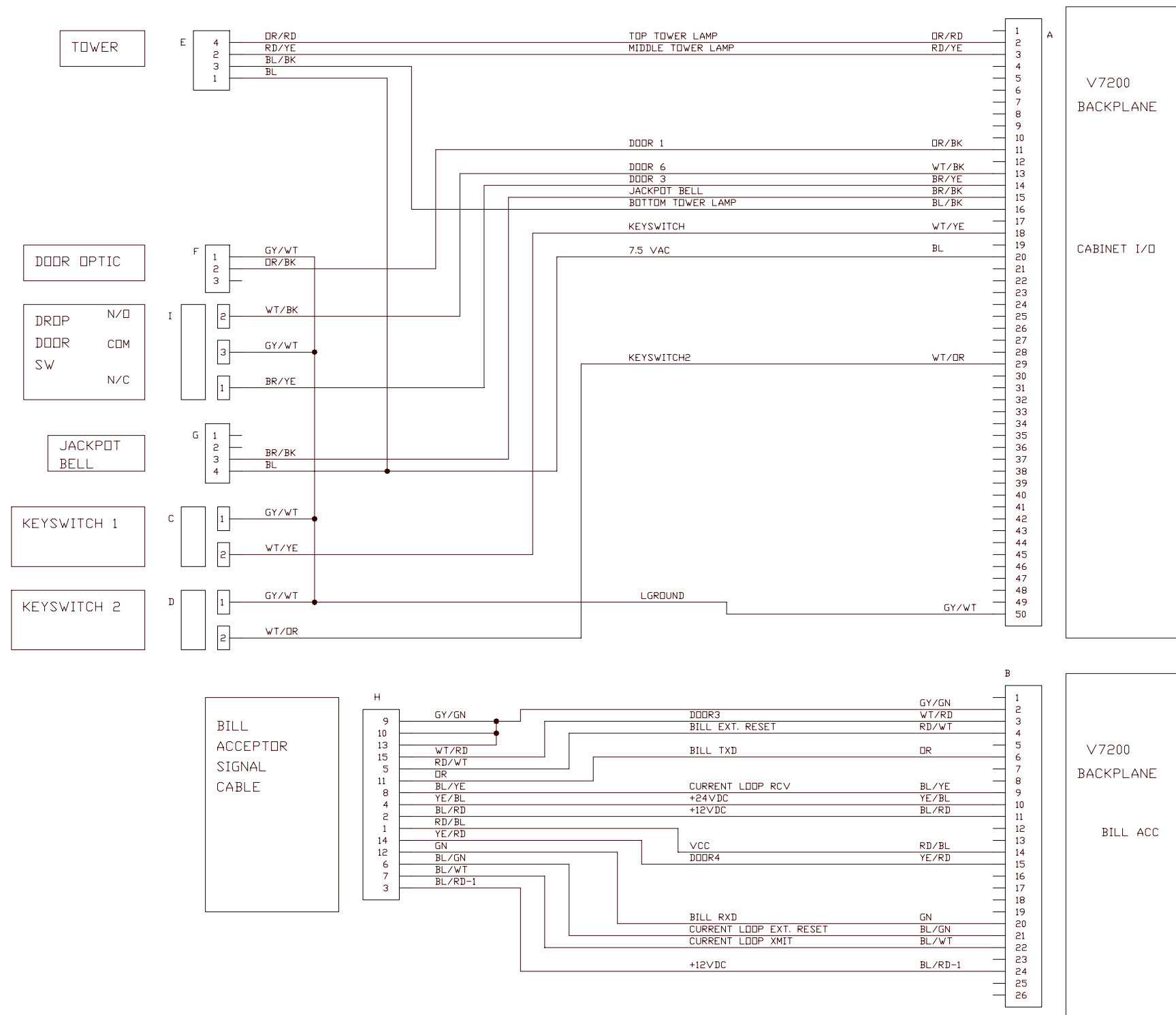

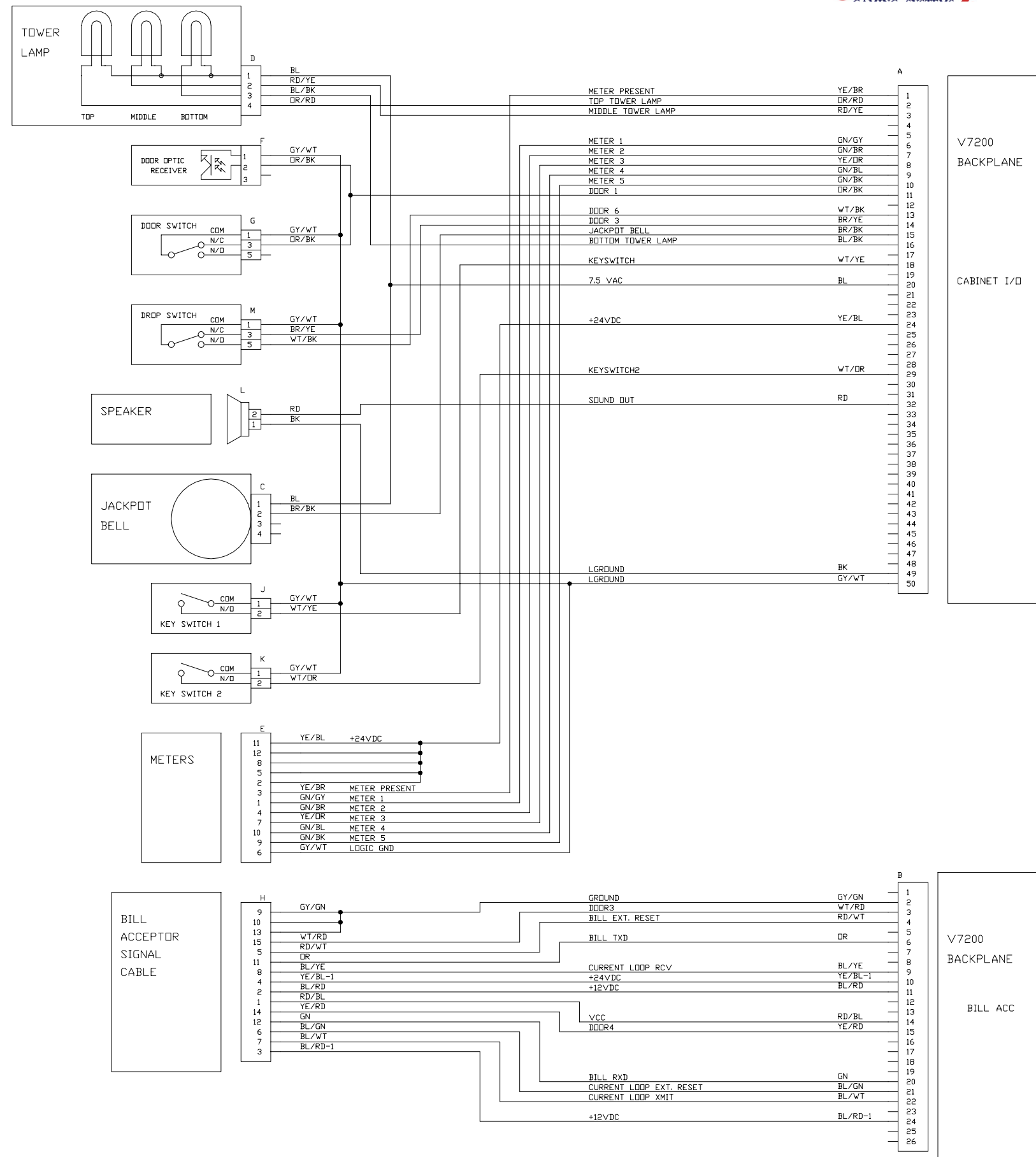

Game Maker-7200™ Upright
Cabinet Power
CBL-30257-0001

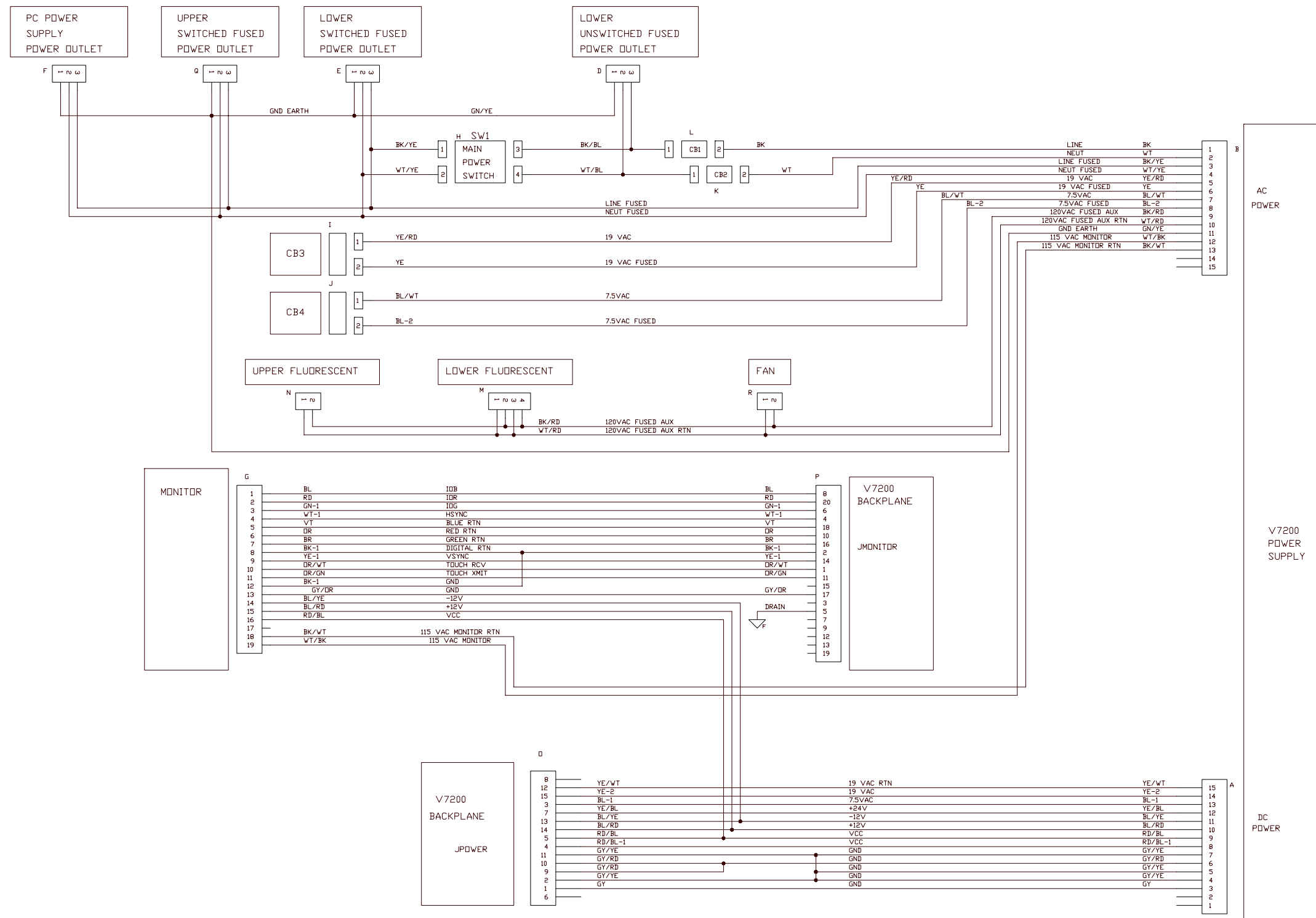

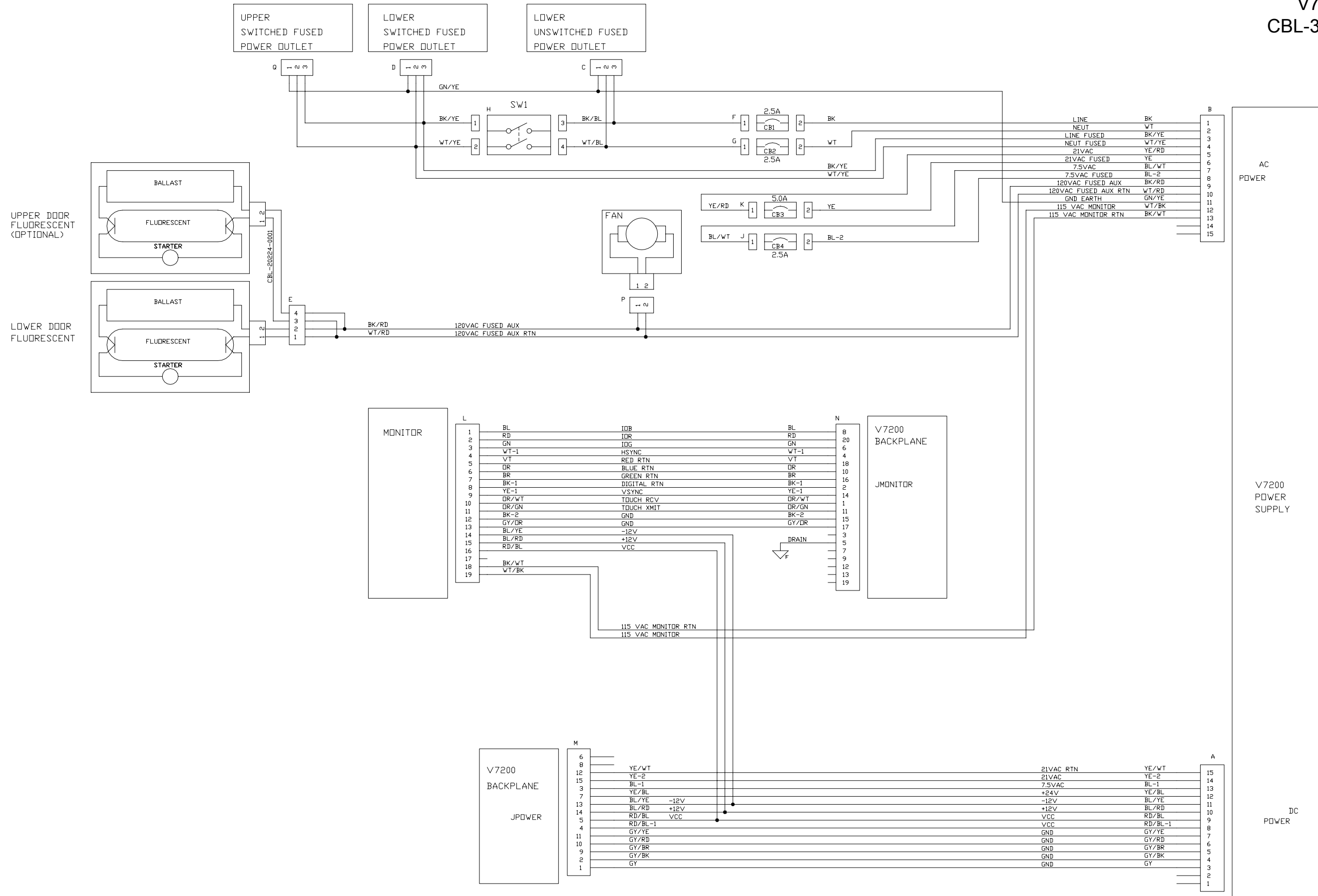

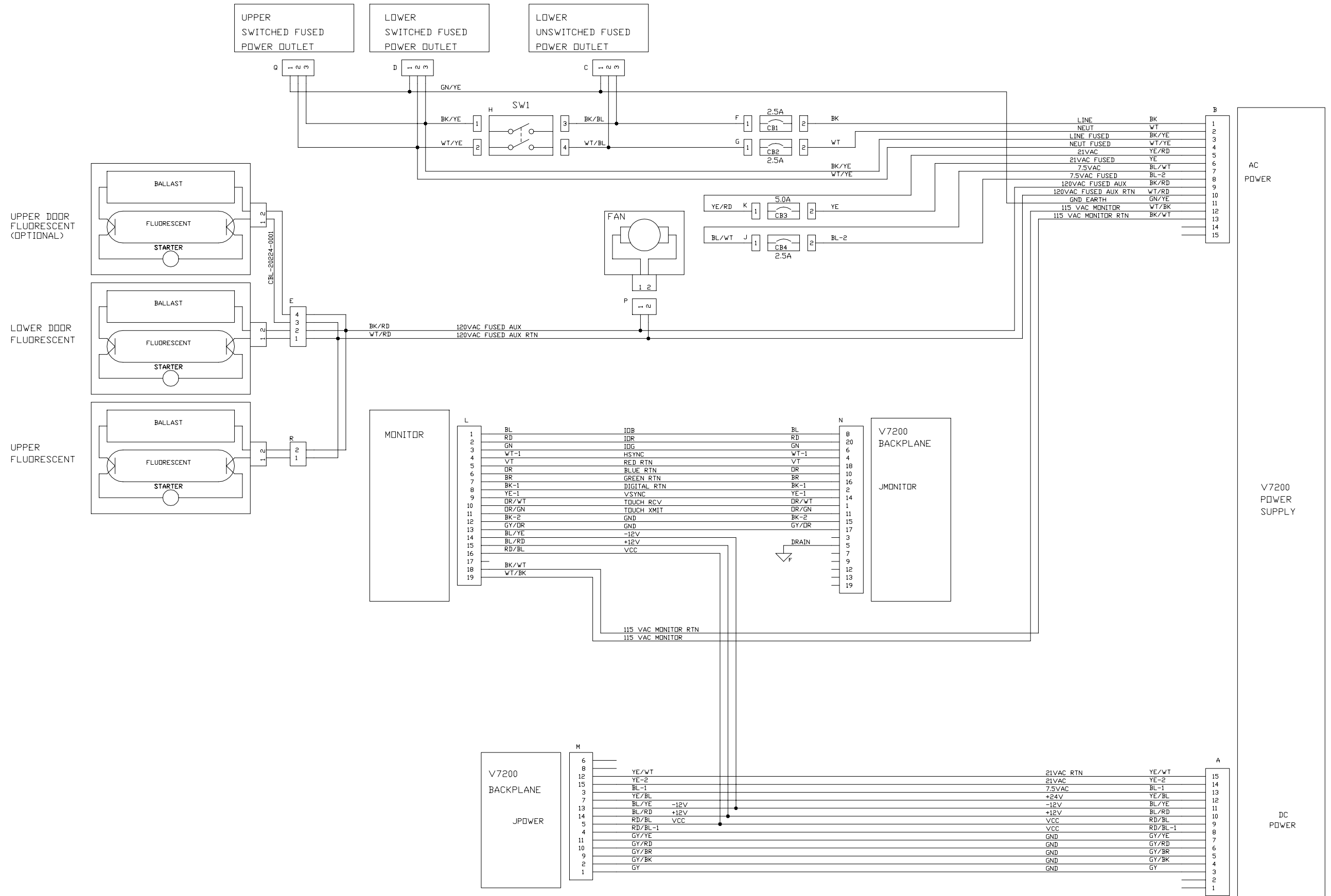

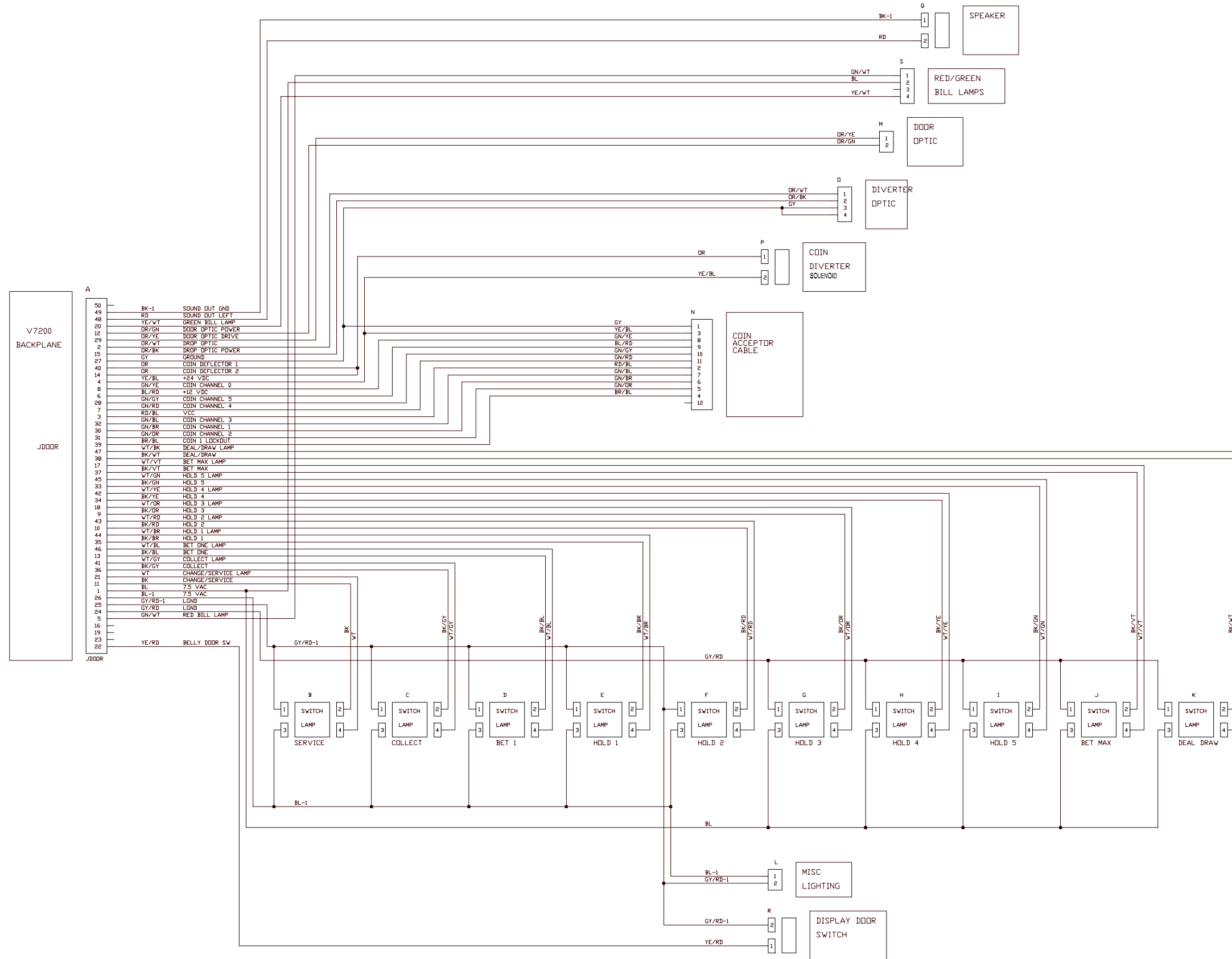

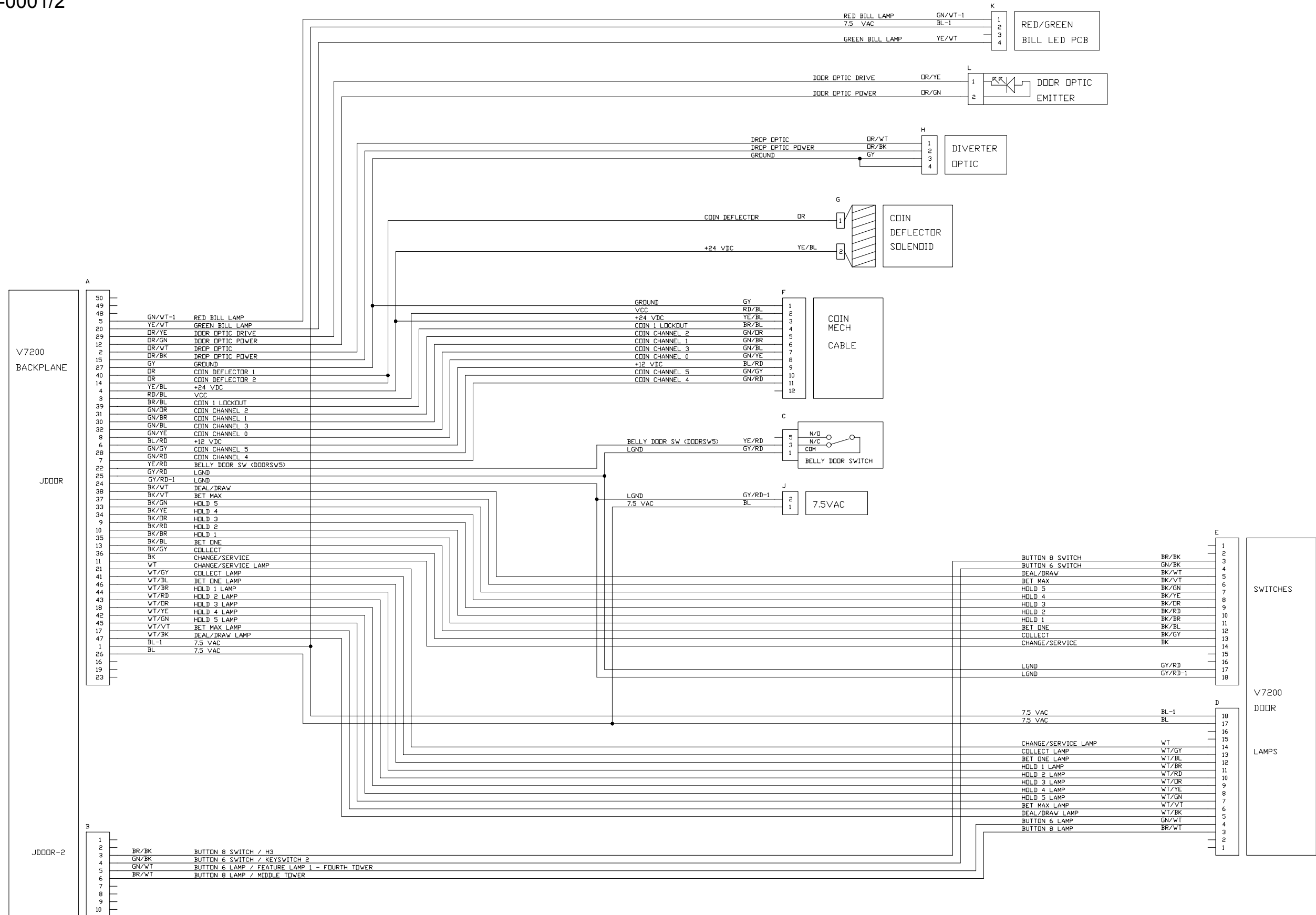

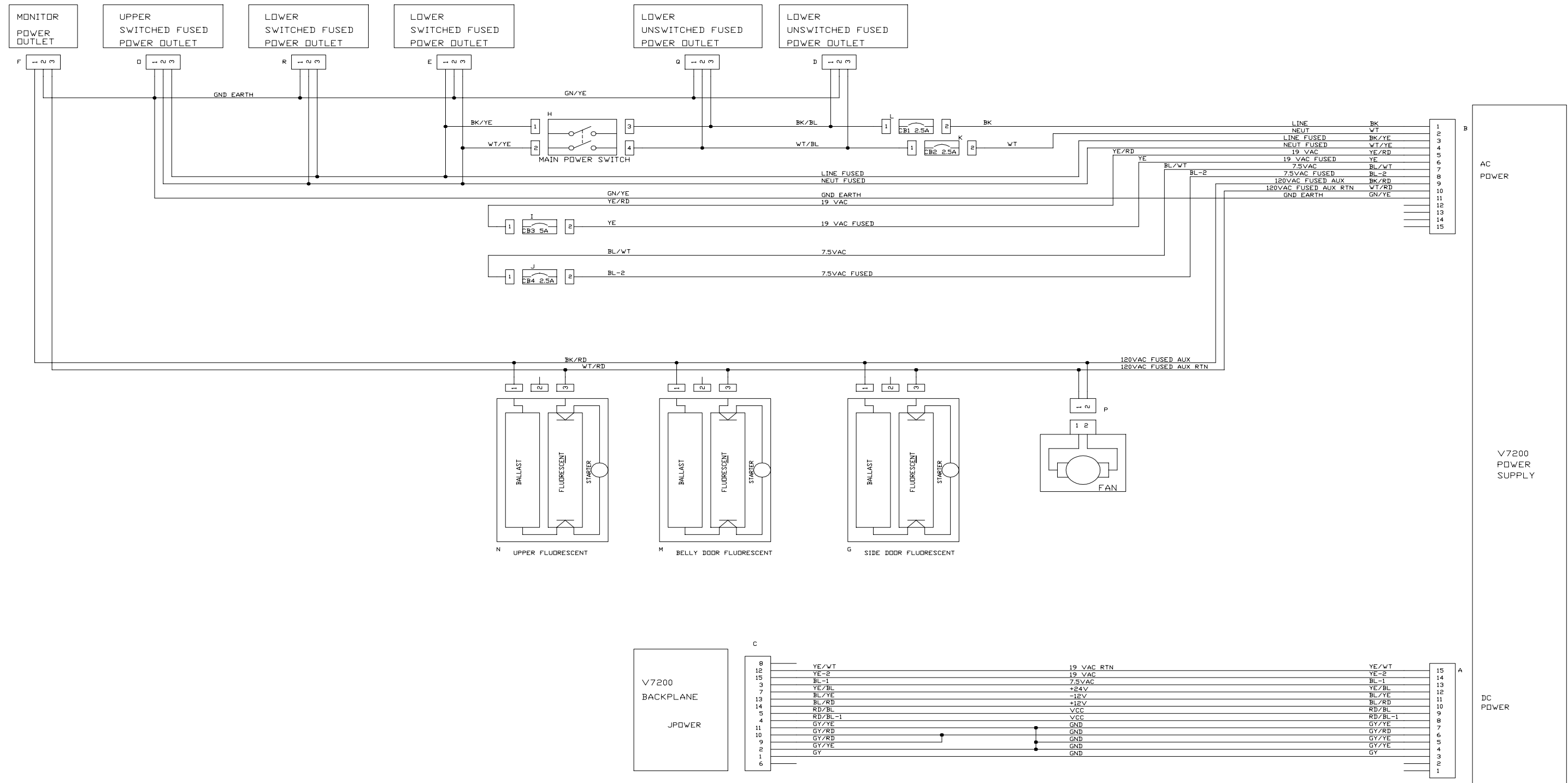

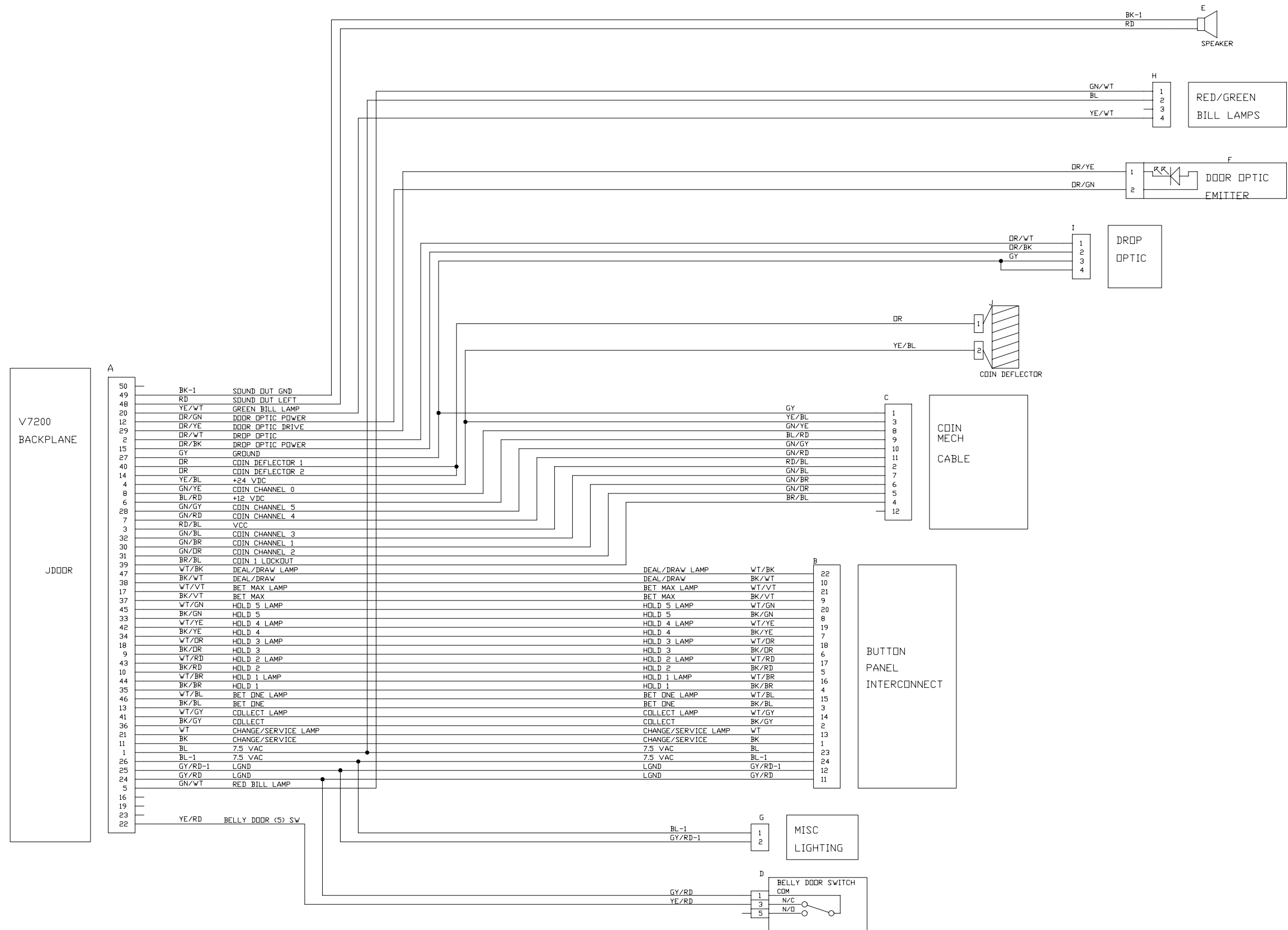

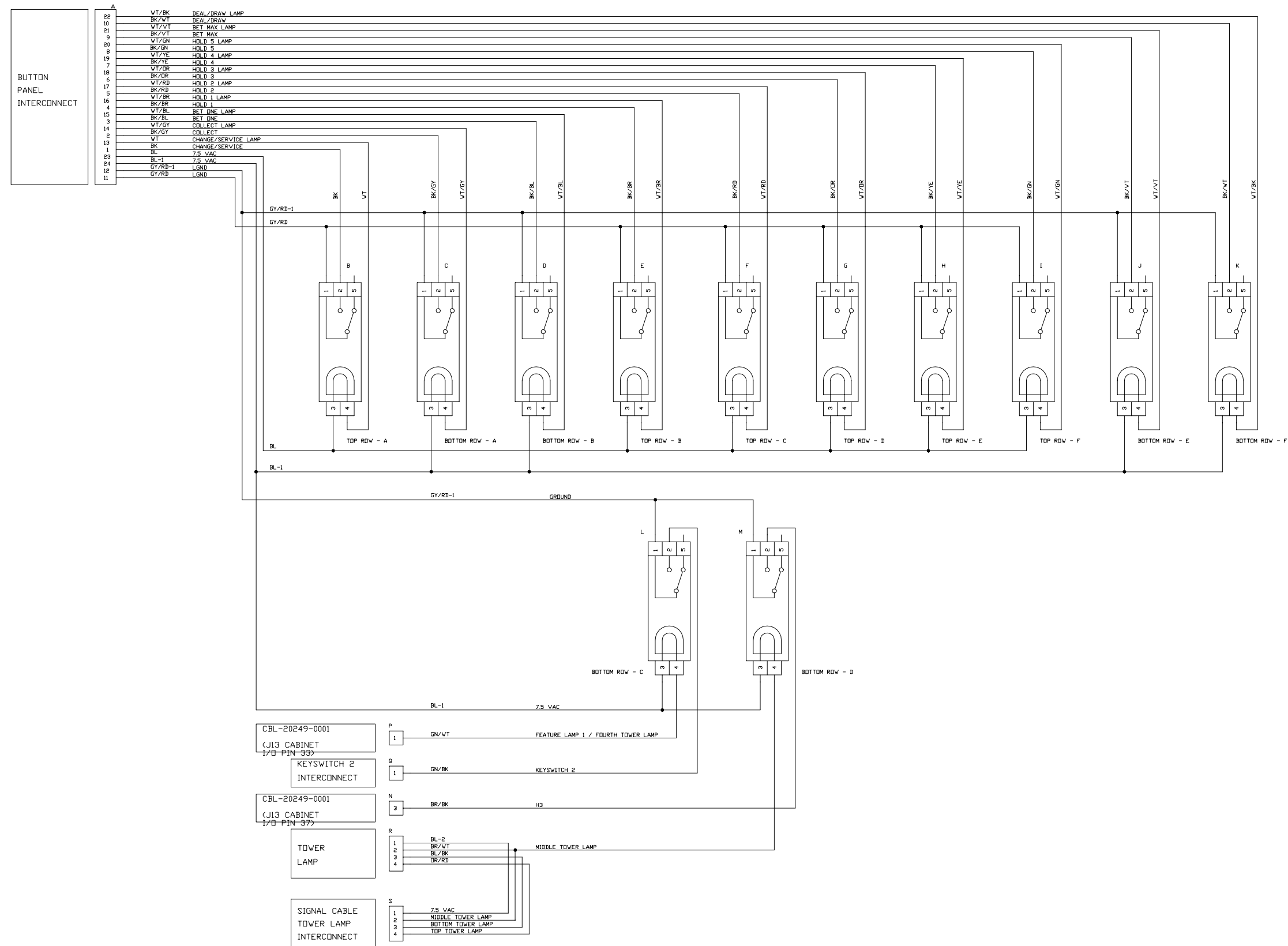

Game Maker-7200™ Upright, Game Maker Plus®

Electro-Mechanical Meters
CBL-20219-0001

Coin Acceptor, CC-46
CBL-20215-0001

Bill Acceptor, WBA 10/20
CBL-20216-0001

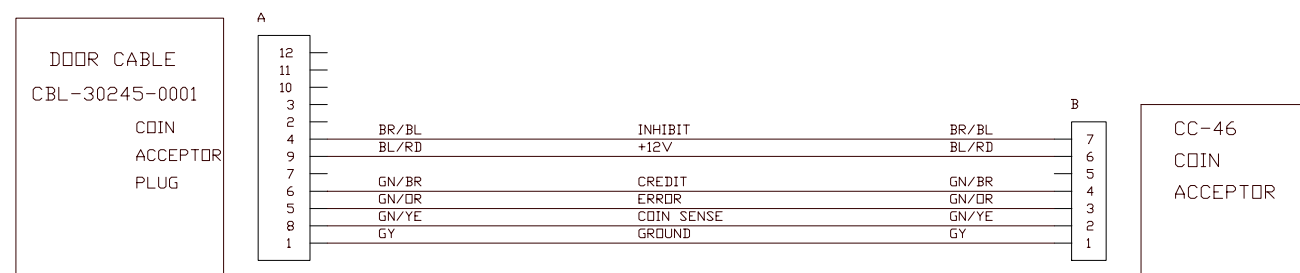
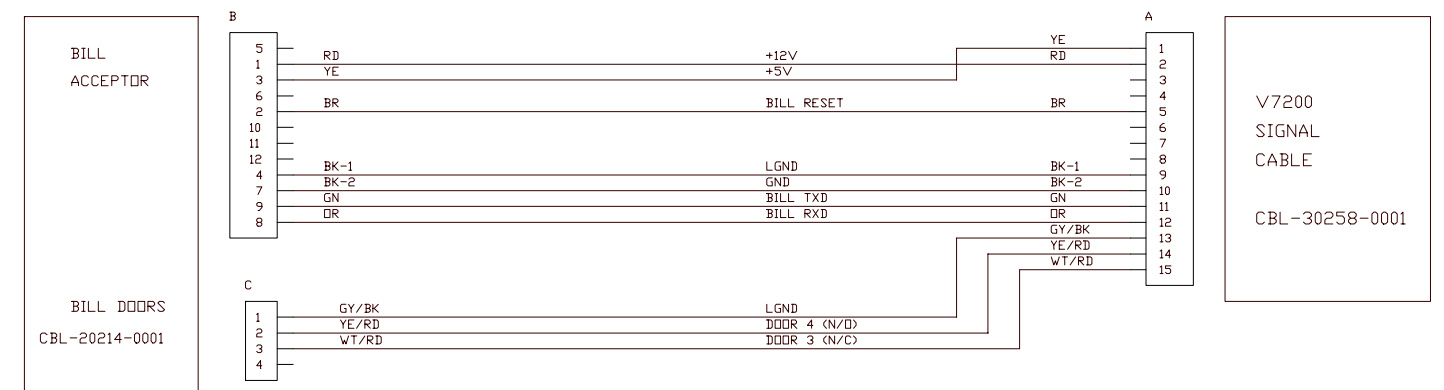
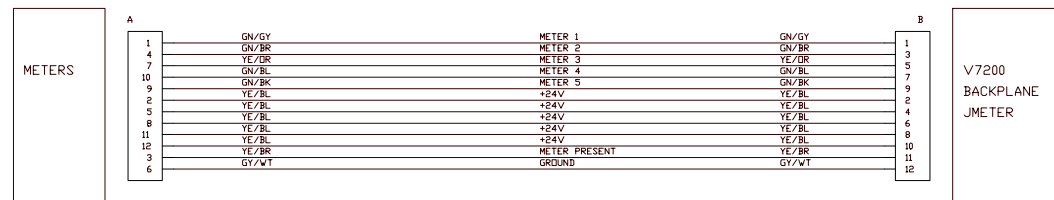

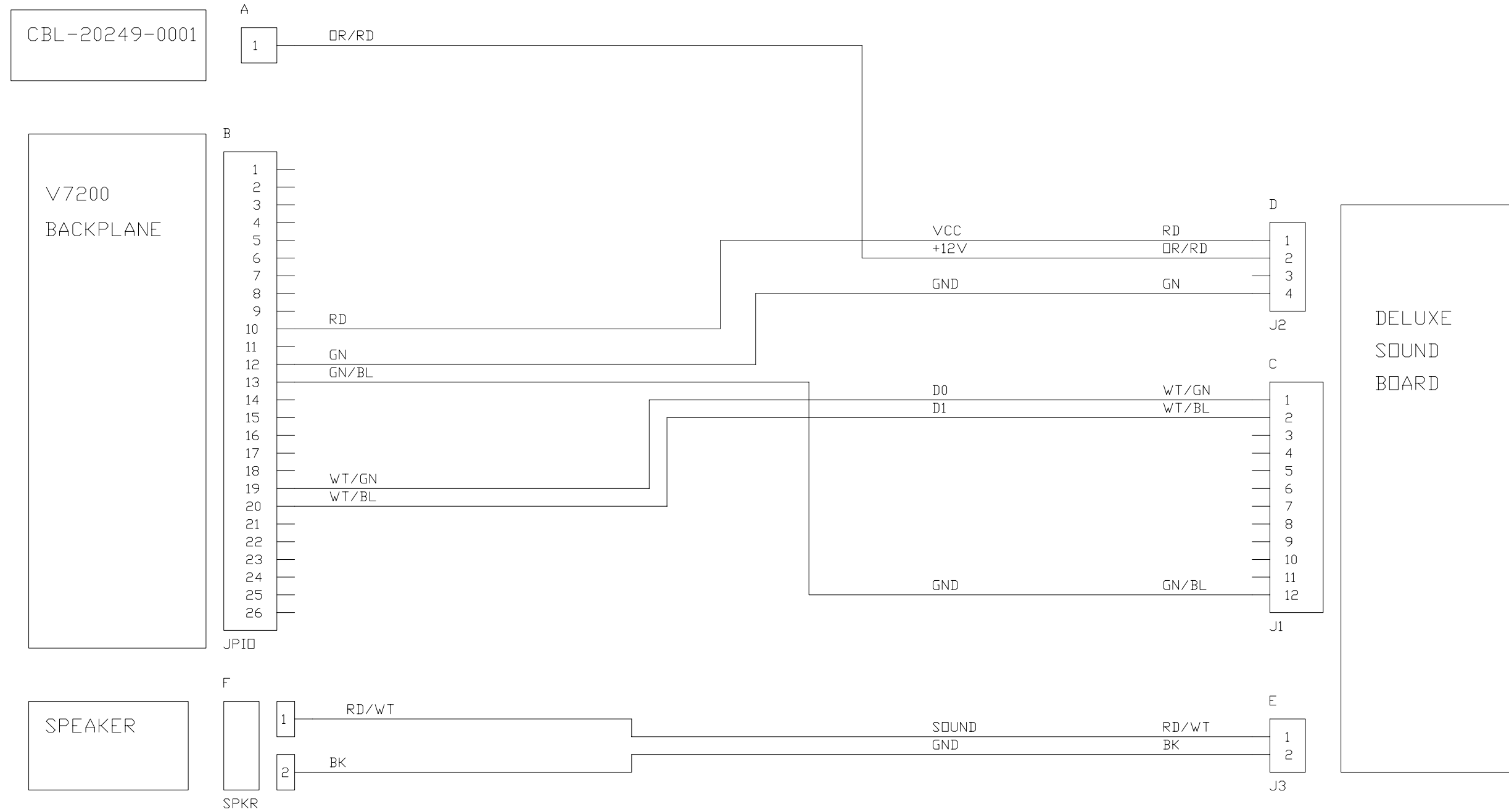

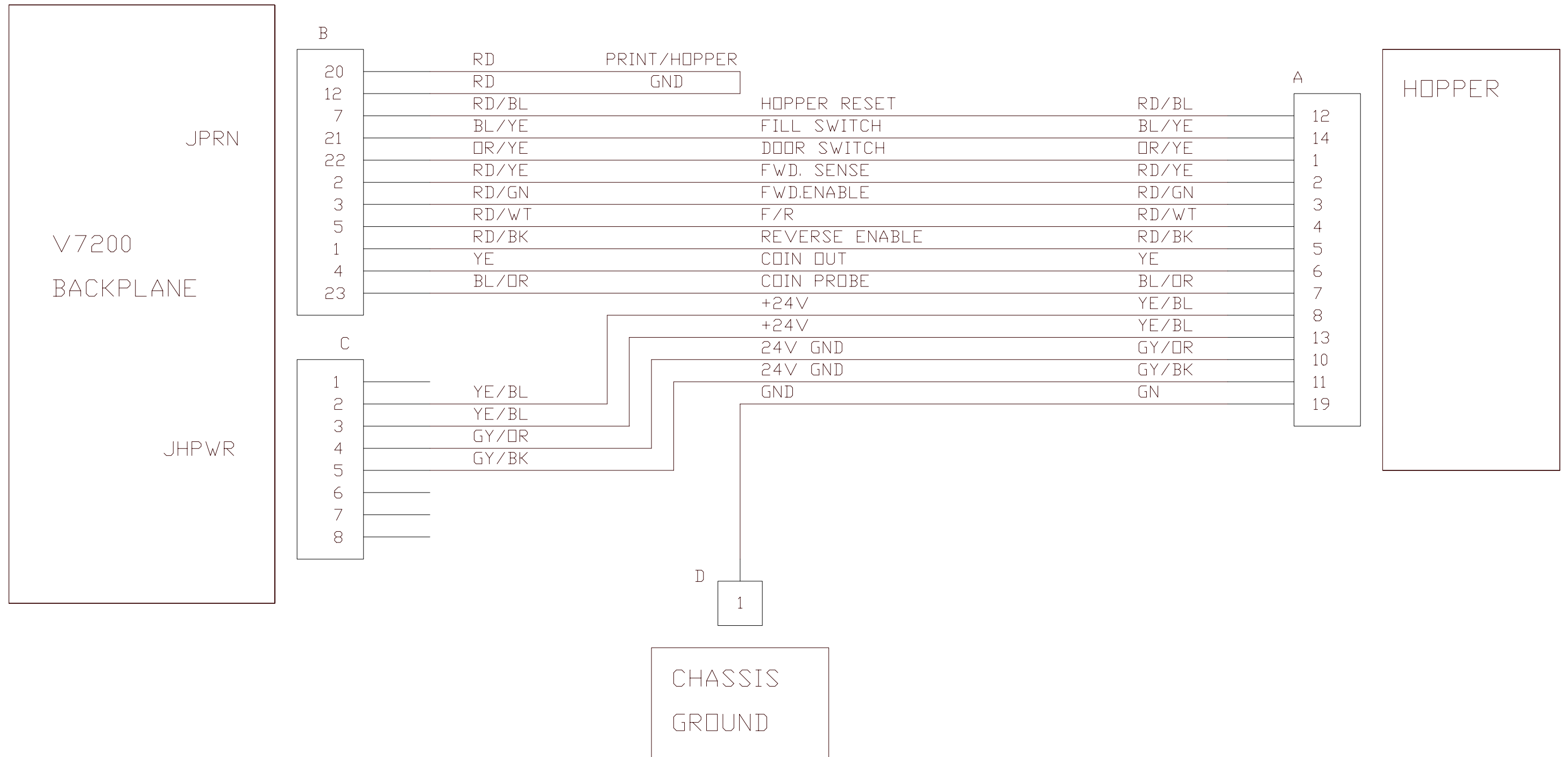

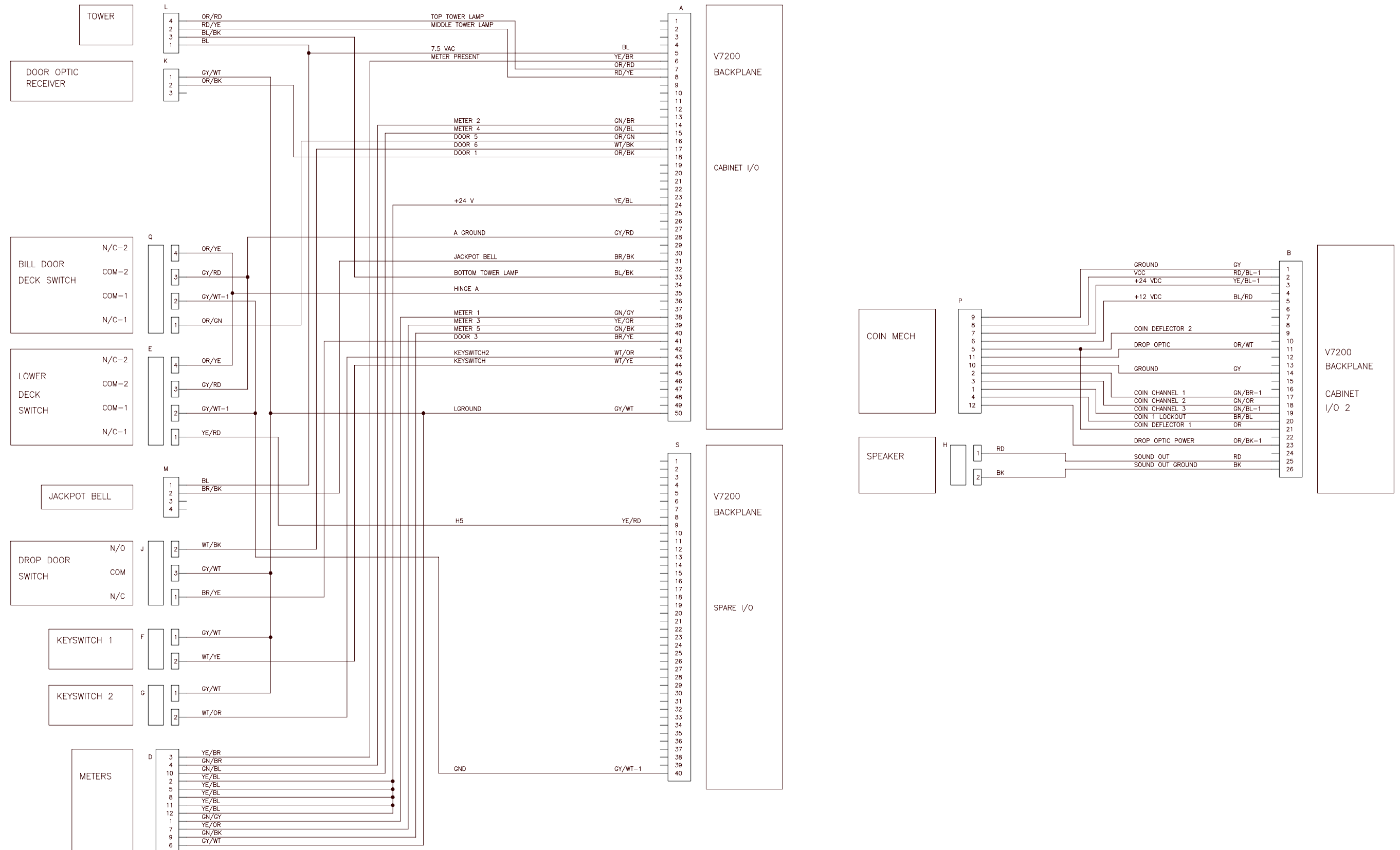

Game Maker-7200™ Slant
Deck
CBL-30246-0001

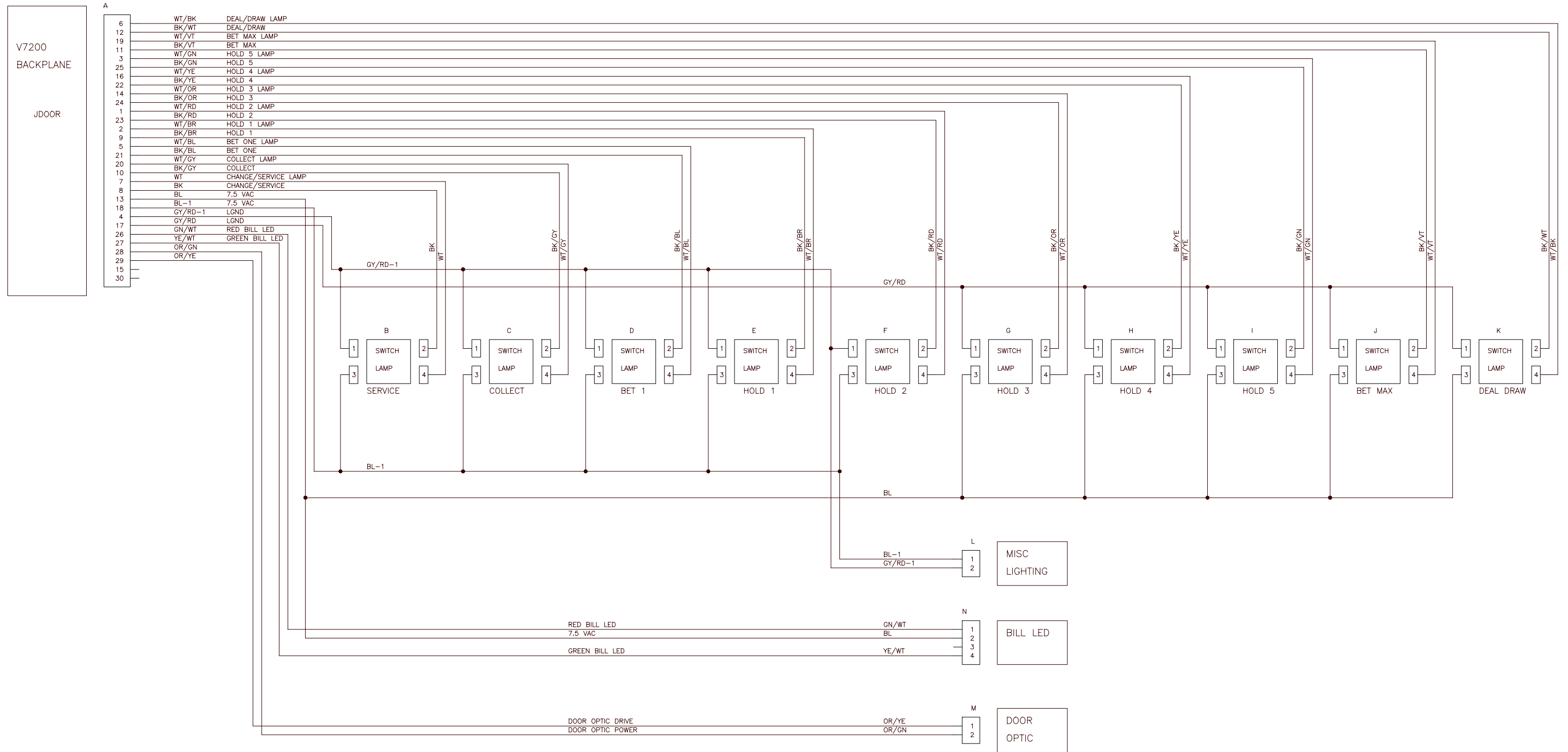

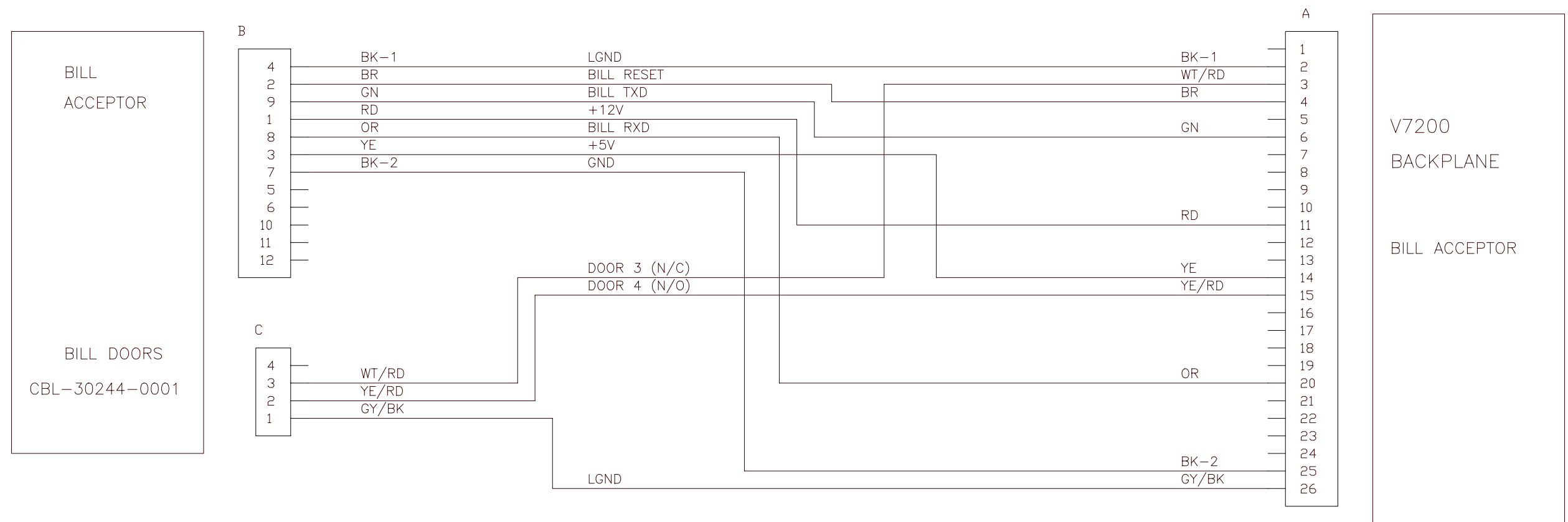

Game Maker® Upright
Power

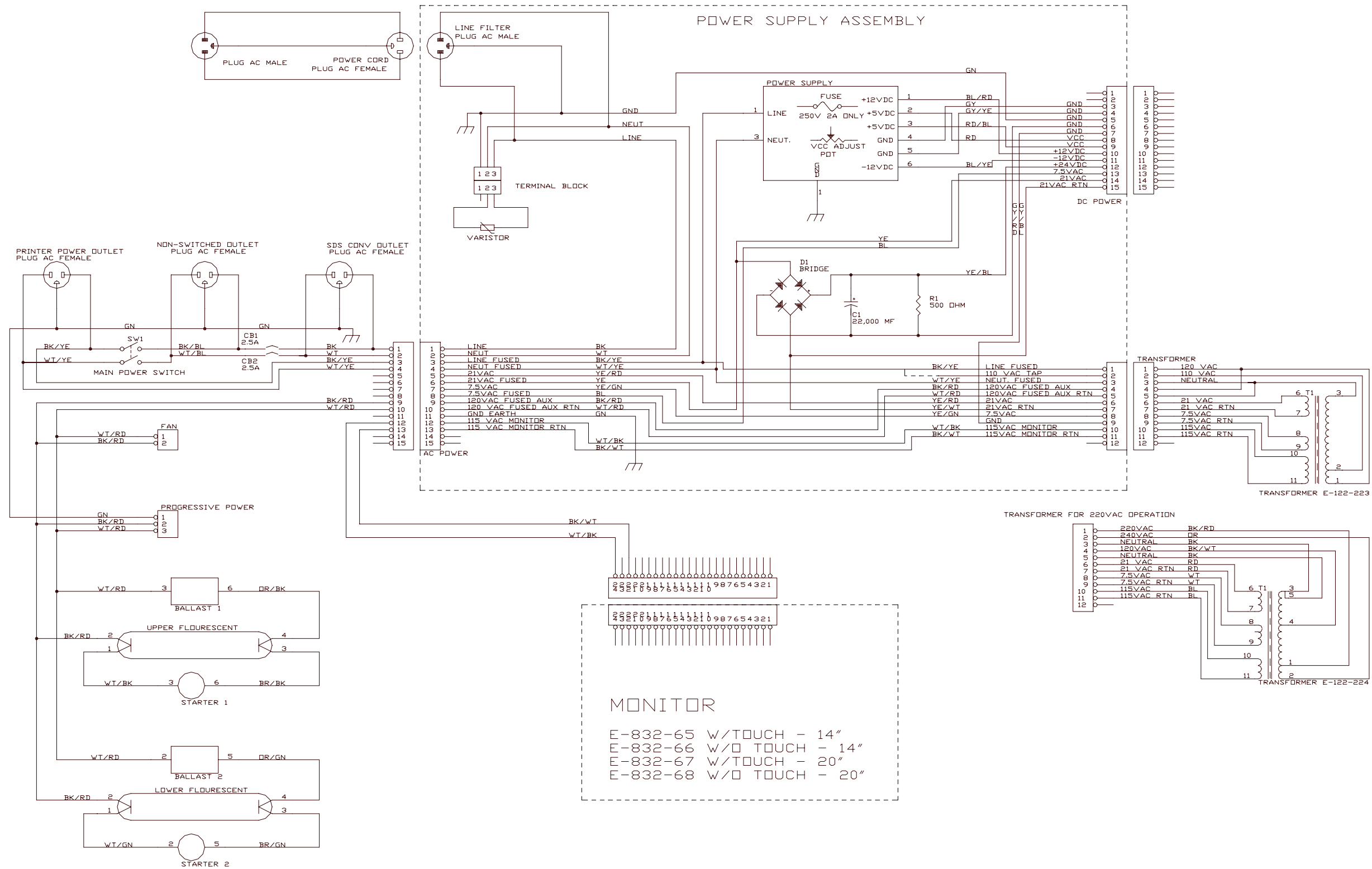

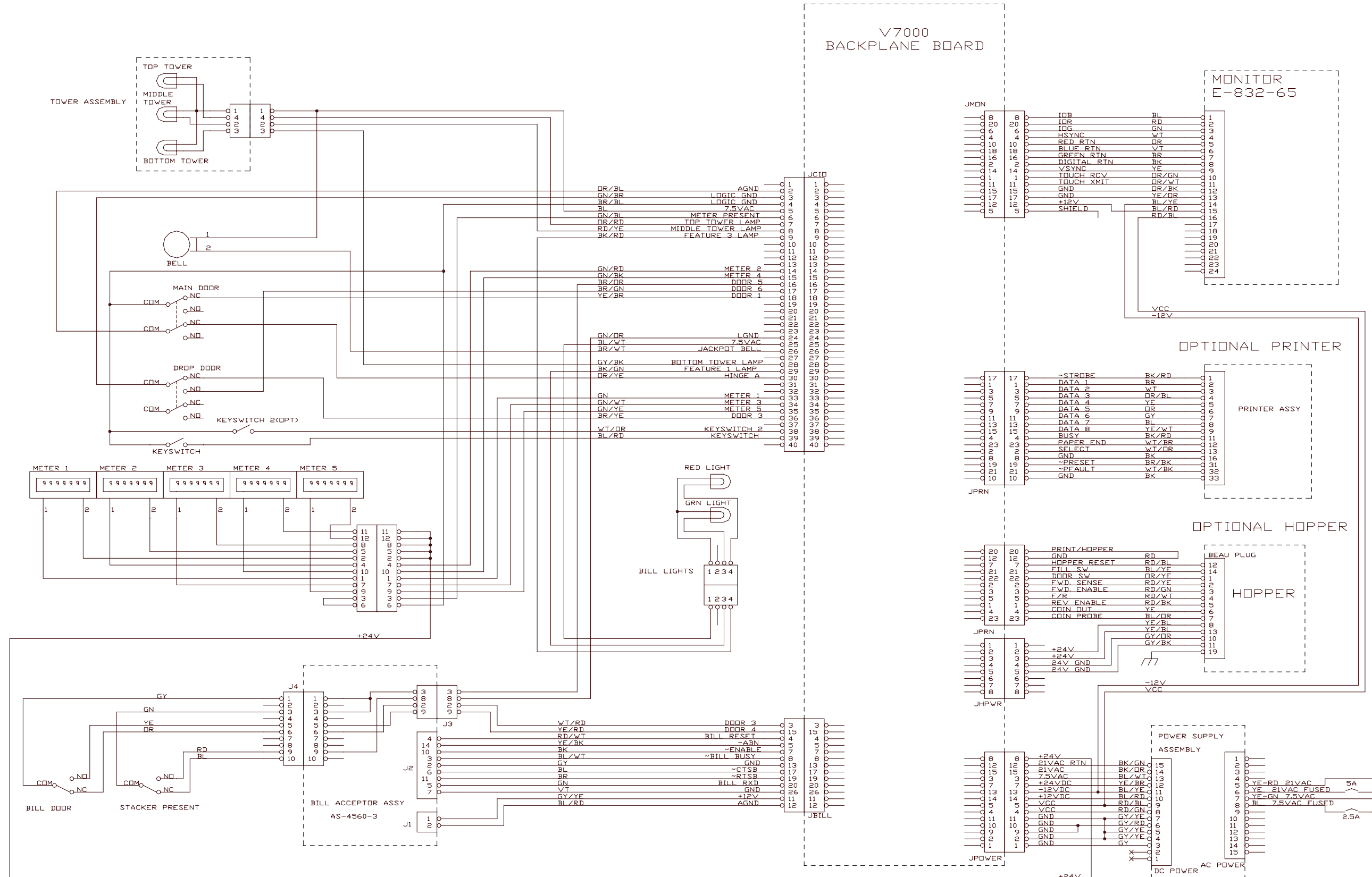

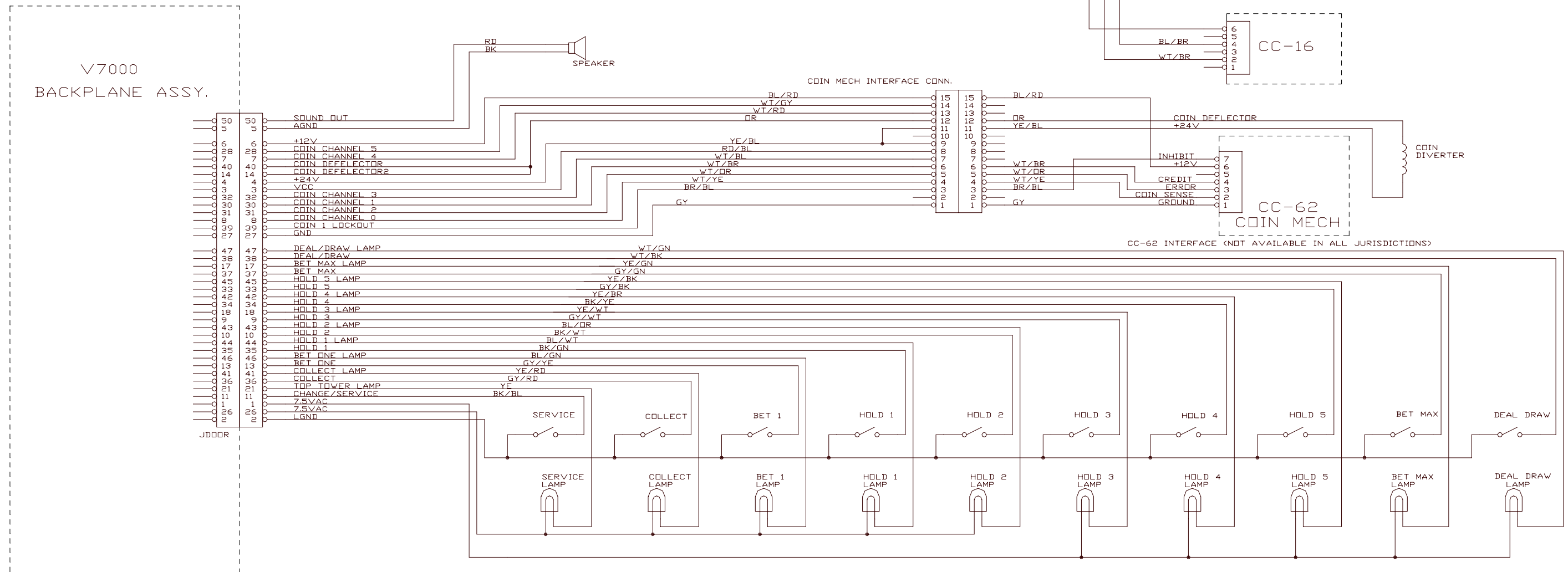

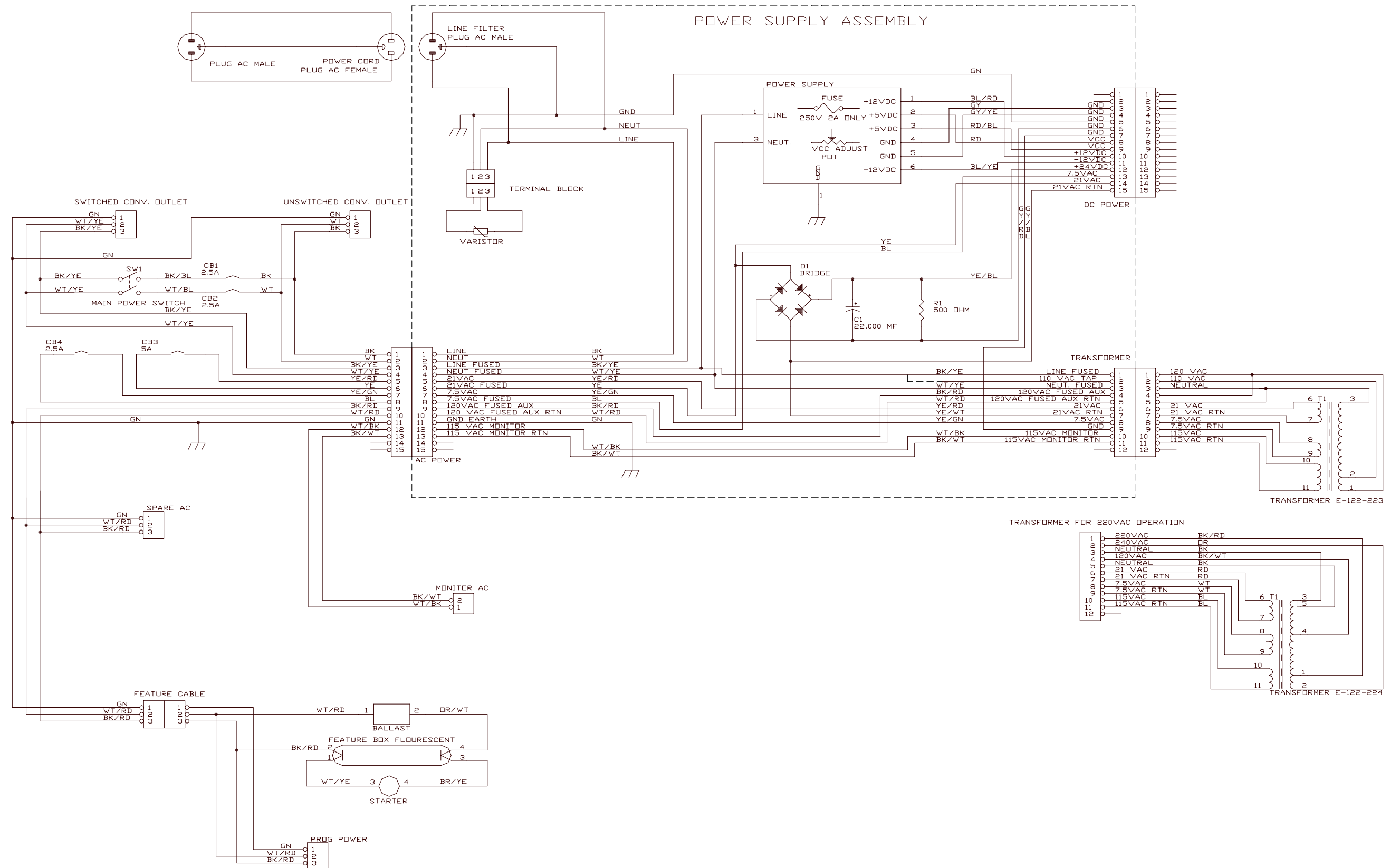

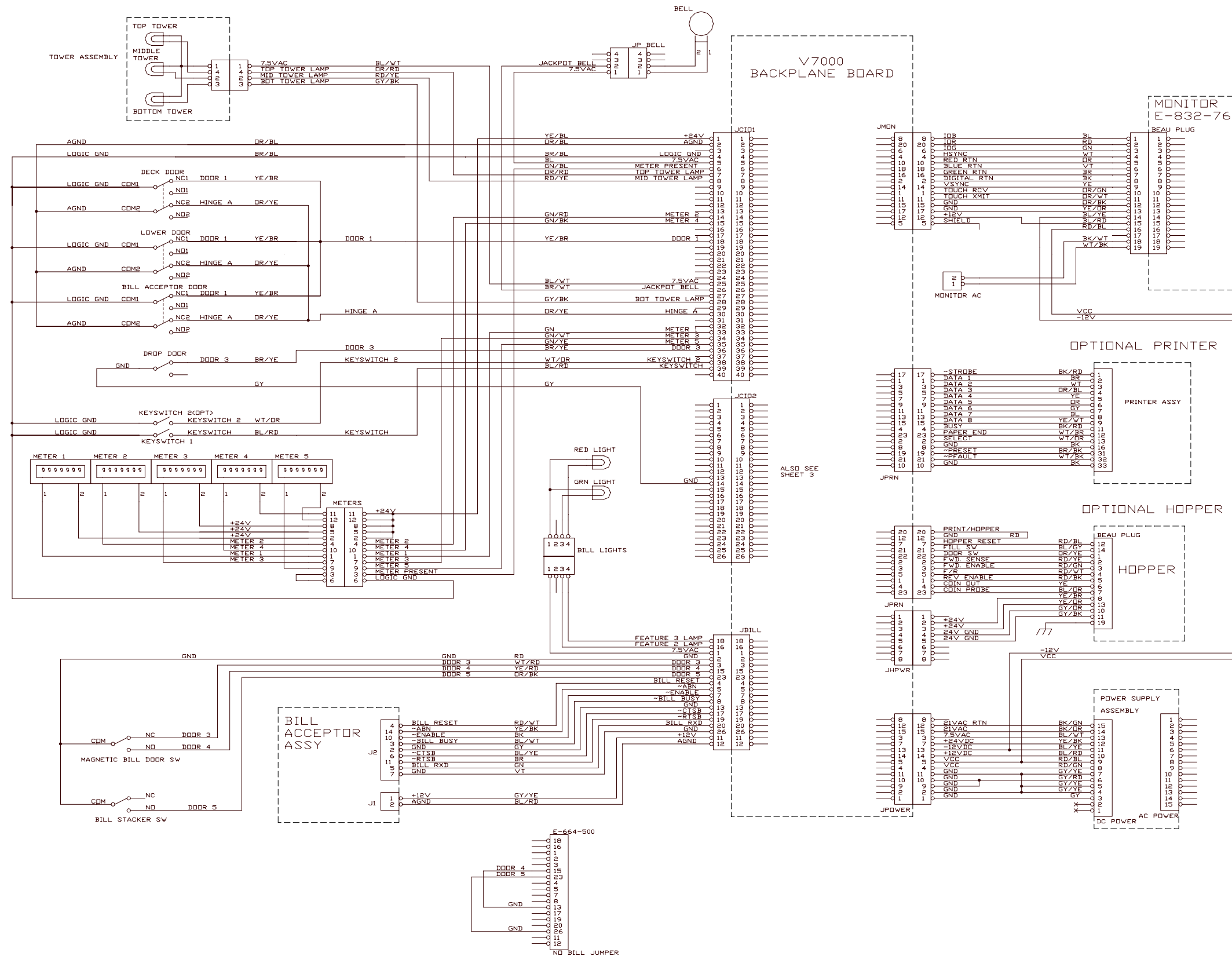

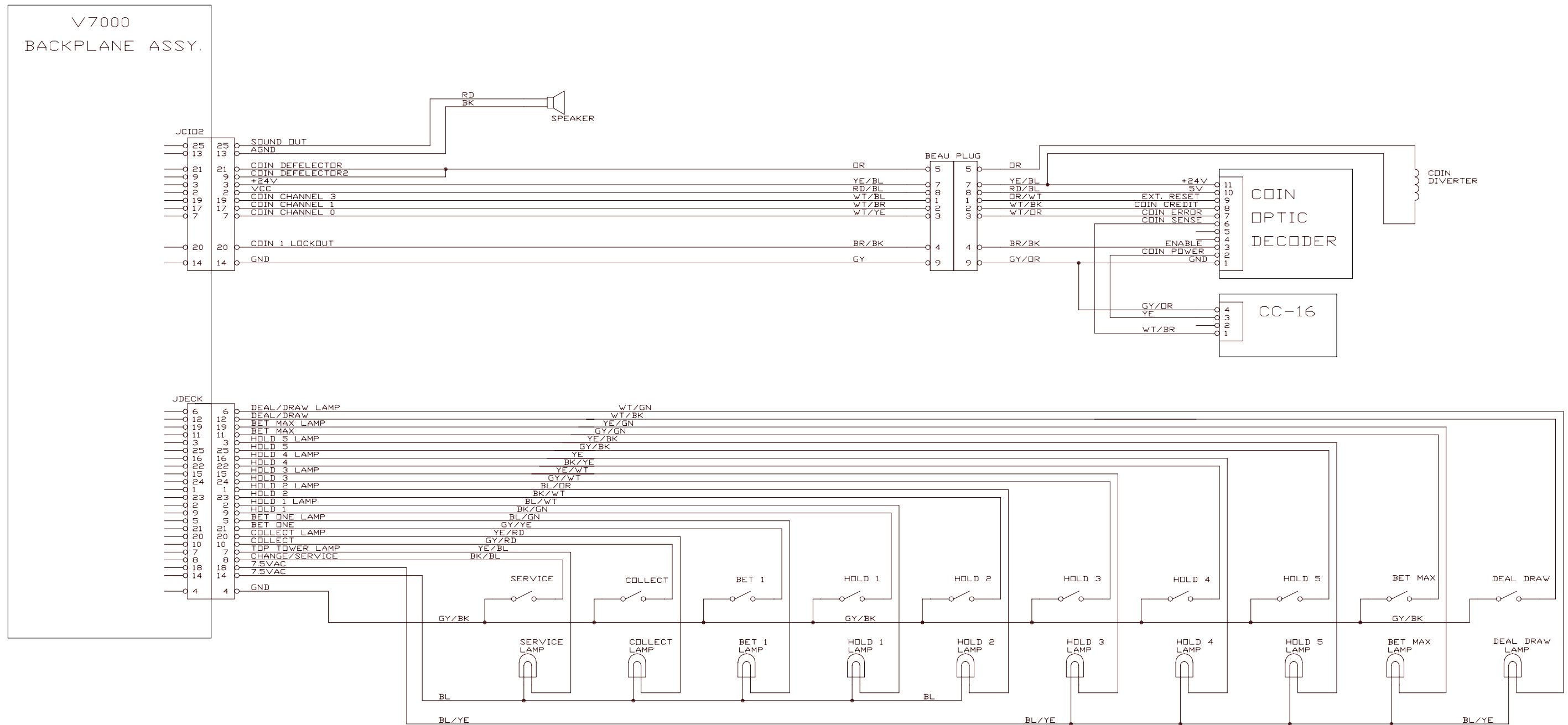

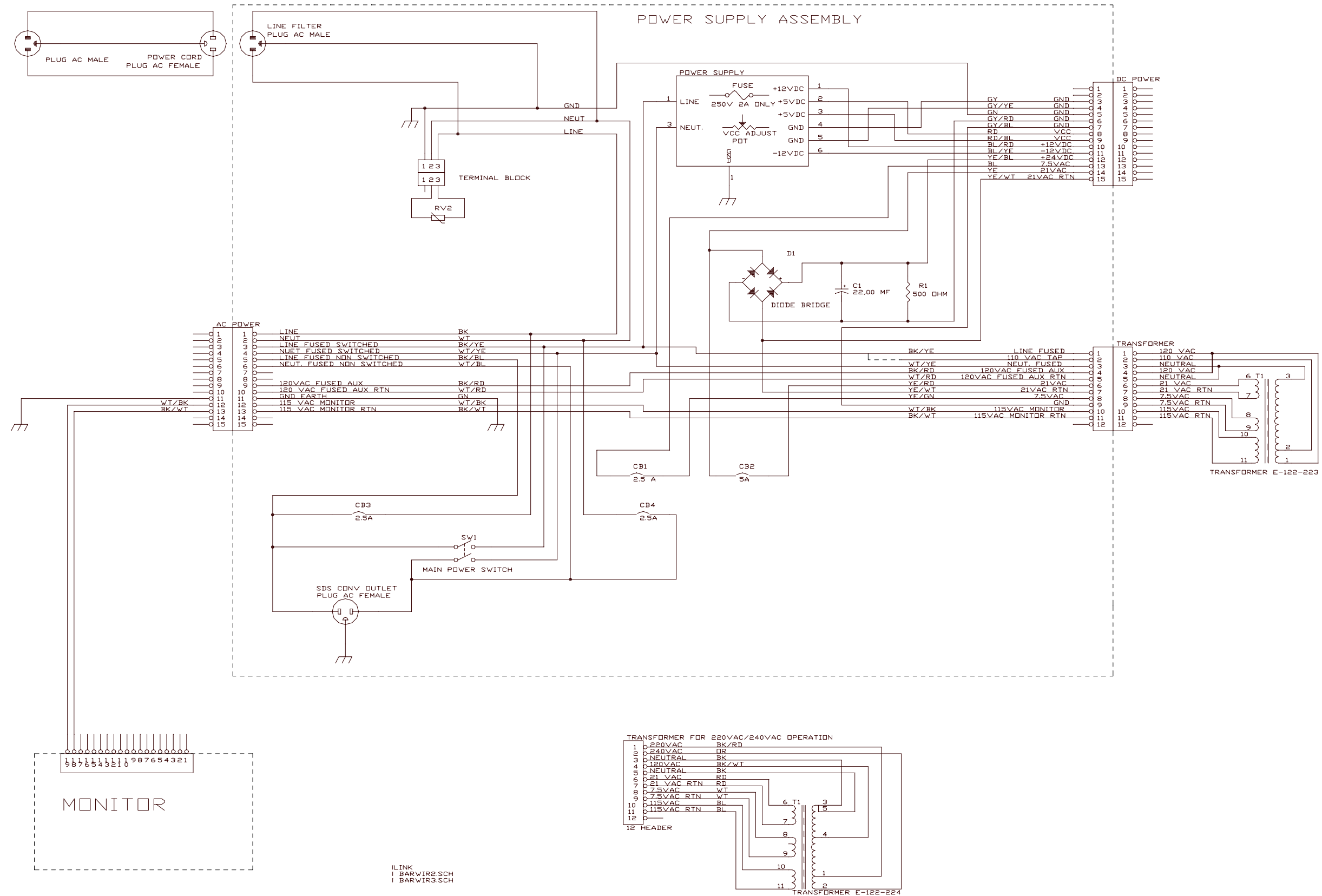

FOR 240VAC OPERATION USE E-122-226 WHICH IS THE SAME AS E-122-224 WITH PINS 1 (BK-RD) AND PIN 2 (DR) SWAPPED.

