



Office: (800) 683-7248 Technical Support: (702) 651-3444 FAX: (702) 651-0214
E-Mail: techsupport@jcm-american.com Web-Site: www.jcm-american.com



EB-100
Bill Validator
Operation and
Maintenance Manual

JCM Part No. 960-000060

Table of Contents

Introduction 1

Specifications 2

EB-100 Body 3

Pin Assignments 4

Disassembly 5

Calibration & Testing 10

Sensor Location 11

Sensor Adjustment 12

Bill Jams 17

System Error Codes 18

Reject Codes 19

EB-100 Test Mode 20

Exploded View 22

Parts List 24

Introduction

EB-100 Bill Validator

The EB-100 multi-currency bill validator combines the latest sensor technology, security, and speed to provide one of the highest acceptance rates of street grade bills in the industry. Bill acceptance is up to 4-way. The EB-100 validates notes in two seconds using multiple wavelength technology, and there is front and rear access to the cash storage.



General Specifications

Outside Dimensions

Width: 93 mm (3.7 in.)
Height: 180 mm (7.1 in.)
Depth: 193 mm (7.6 in.)

Weight

1 kg (2.2 lb)

Power Requirements

DC +12V ($\pm 5\%$), Standby +4VA,
Operating 8.2VA (Max. 18VA)

Cash Box Capacity

400 notes

Validation Speed

Two seconds

Environment

Operating 5° - 50°C , Storage -20° -
Humidity 30% - 85% RH (Non-Condensing)

Note Insertion

4-way, Width 67 – 77 mm (2.6 – 3 in.)

Installation

Horizontal mounting, Internal use only

Software

Software upgrades are released for currency changes, increased security, and feature enhancements

Technical Support

Training classes are available for all JCM products

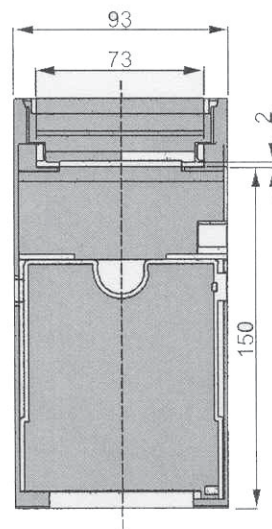
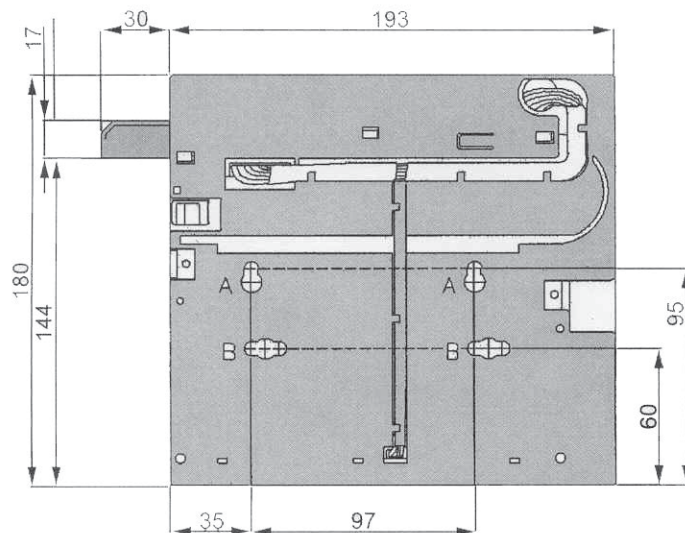

EB-100 General View

Front View

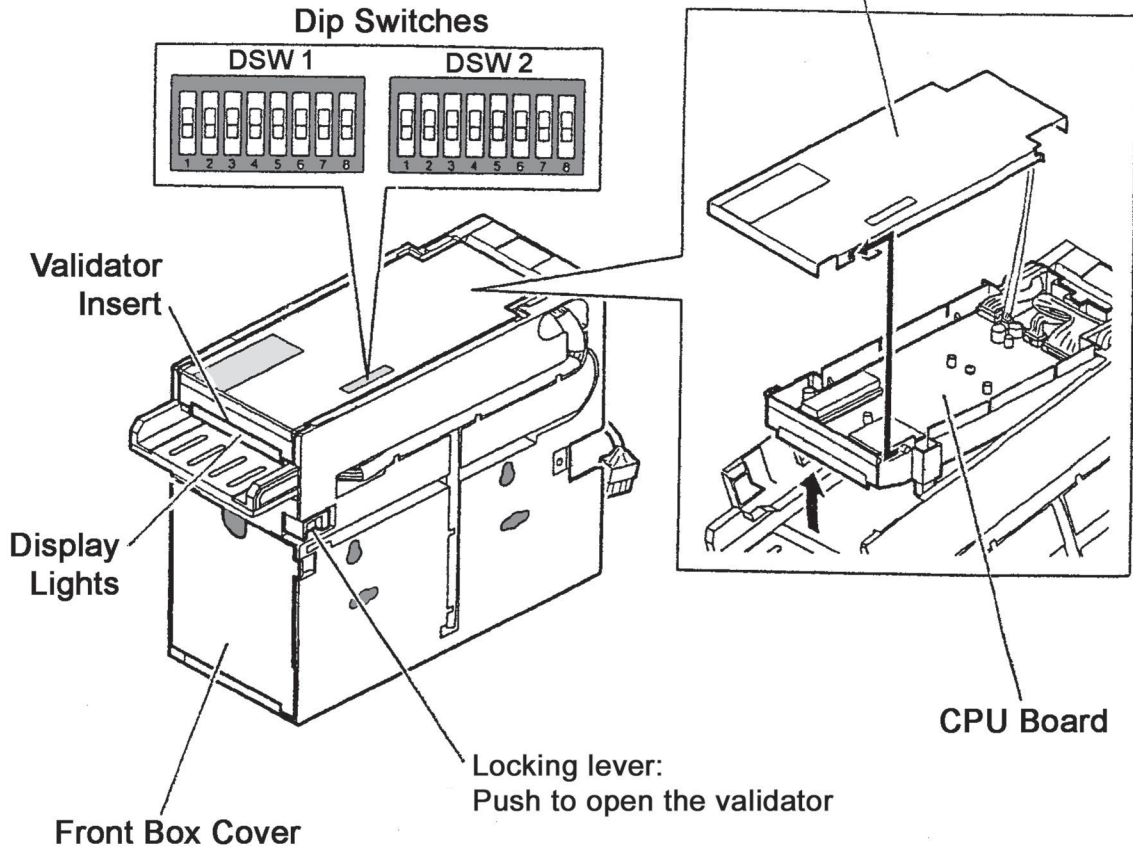

Rear View

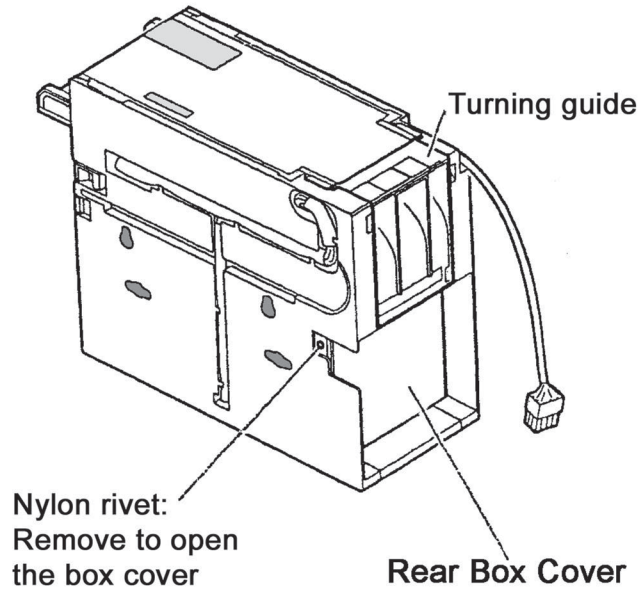

Pin Assignments

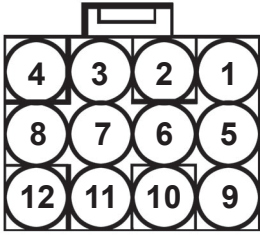

Front View - EB-100 Connector

Connector Specifications

Plug Housing	ELP-12V (Manufacturer: JST)
Material	Nylon 6, UL94-VO white
Socket Contact	SLF-01T-P1.3E

Recommended Mating Connector

Receptacle Housing	ELR-12V (Manufacturer: JST)
Material	Nylon 6, UL94-VO white
Pin Contact	SLM-01T-P1.3E (AWG#20-26) SLM-41T-P1.3E (AWG#16-20)
Recommended Wire	AWG#20-26, UL 1007

Serial

Pin #	Signal Name	I/O	Definition	Wire Size
1	TXD	Output	Acceptor data transmit	AWG #26 UL1007
2	RXD	Input	Acceptor Data receive	AWG #26 UL1007
3	Vcc	Output	DC 5V output (+/-5%). Max 20mA	AWG #26 UL1007
4	SCOM		Signal ground	AWG #26 UL1007
5	VDD	Input	Power supply DC +12V	AWG #26 UL1007
6	NC		Reserved	
7	F-GND		Connected to frame ground	AWG #26 UL1007
8	Vss		Power supply ground	AWG #26 UL1007
9	NC		Reserved	
10	NC		Reserved	
11	NC		Reserved	
12	NC		Reserved	

Pulse

Pin #	Signal Name	I/O	Active	Definition	Wire Size
1	VEND	Output	LO	Bill acceptance denomination signal	AWG #26 UL1007
2	NC			Reserved	
3	Vcc	Output		DC 5V output (+/-5%). Max 20mA	AWG #26 UL1007
4	SCOM			GND for signal line	AWG #26 UL1007
5	Vdd	Input		Power supply 12V (+/- 5%)	AWG #26 UL1007
6	NC			Reserved	
7	F-GND			Connected to frame ground	AWG #20 UL1007
8	Vss			GND for power supply 12V	AWG #26 UL1007
9	BUSY	Output	HI	Output signal when acceptor operating	AWG #26 UL1007
10	INH	Input	HI	Bill acceptance inhibition signal (*1)	AWG #26UL1007
11	ABN	Output	HI	Output signal when acceptor fails	AWG #26 UL1007
12	FULL	Output	LO	Output signal when bill stacker is full	AWG #26 UL1007

*1 When INH signal line is open, acceptor is inhibited from accepting a bill.
When INH signal is out of service, connect the pin 10 to SCOM

Disassembly

This section describes the disassembly procedure which may be necessary for trouble-shooting and repairing the unit. The assembly procedure is the reverse of this procedure.

This manual and tools are required to disassemble this unit.

Necessary tools:

- Precision screwdriver (Phillips)
- Flat-head screwdriver

IMPORTANT: Make sure there is no power to the unit before beginning the work.



1. Push the white button to open the validator cover.

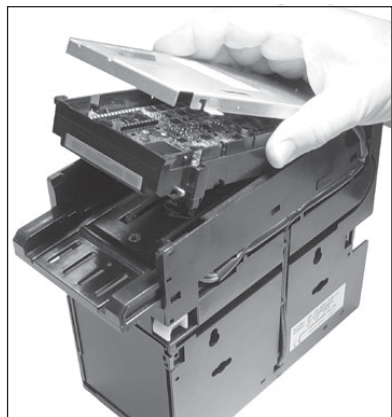

2. Push the CPU cover forward slightly to open it.

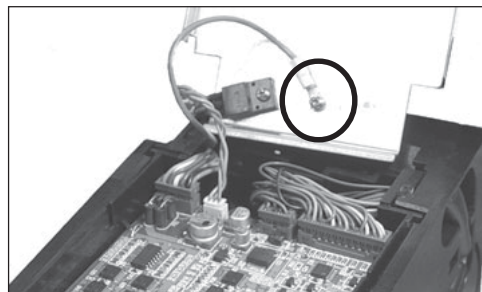

3. Unscrew the ground wire terminal from the CPU cover and disconnect the transistor harness from the CPU board.

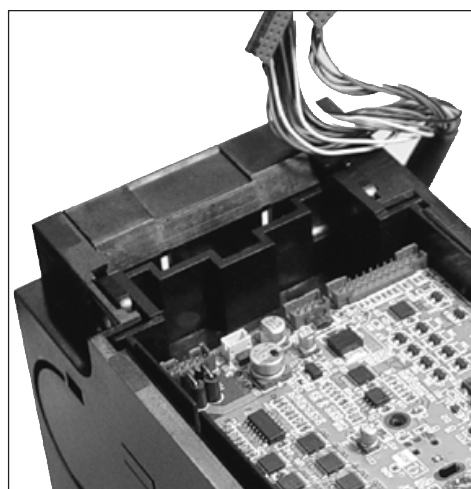

4. Disconnect all harnesses and remove through the holes in the side of the box.

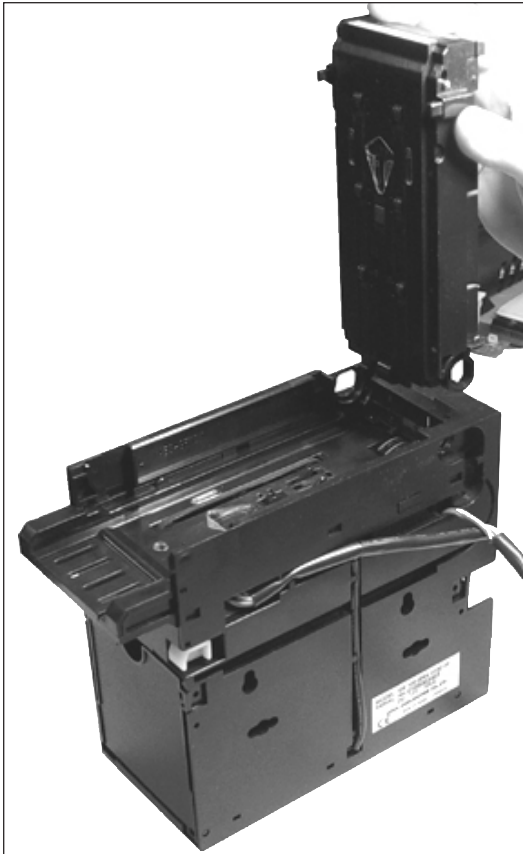

- 5.** Lift the validator head all the way up, then gently rotate it back and forth out of the frame.



- 7.** Gently spread the box sides to remove the front and rear doors.



- 6.** Remove the side guides by pulling forward and lifting.

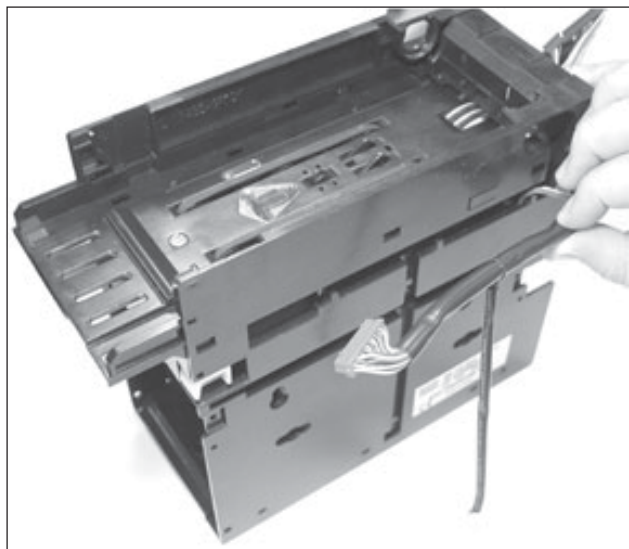

- 8.** Disconnect the harnesses on the side of the box.

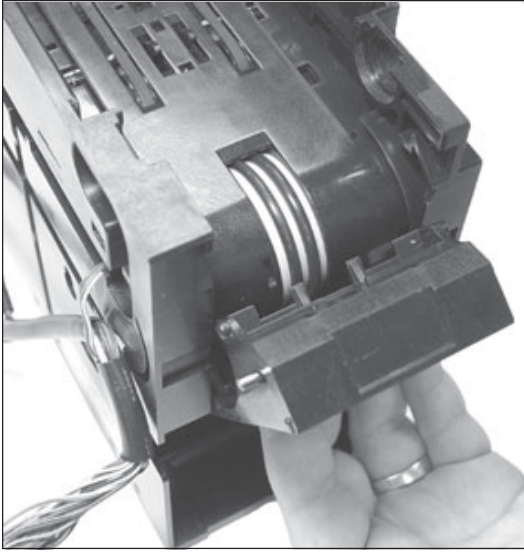

- 9.** Lift the bar to open, then spread the sides slightly to remove the turning guide.



- 10.** Place a flat-edged screwdriver under the tab on the side and raise it.

WARNING: The tabs are fragile! Do not use force!

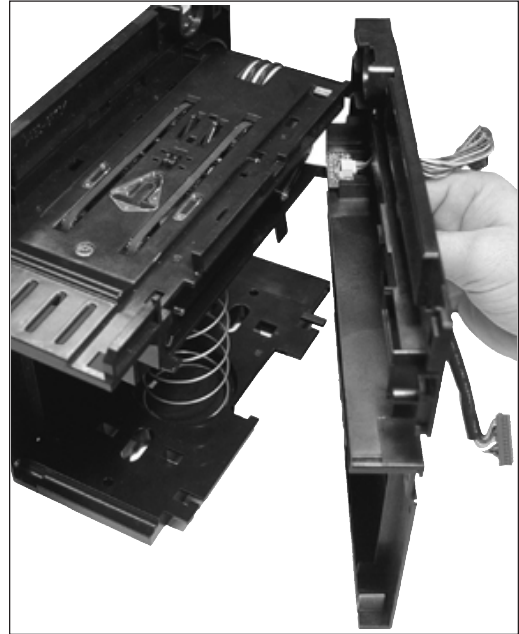

- 11.** While tab is raised push the side backwards to release the side panel. Repeat Steps 10 and 11 for the other side.

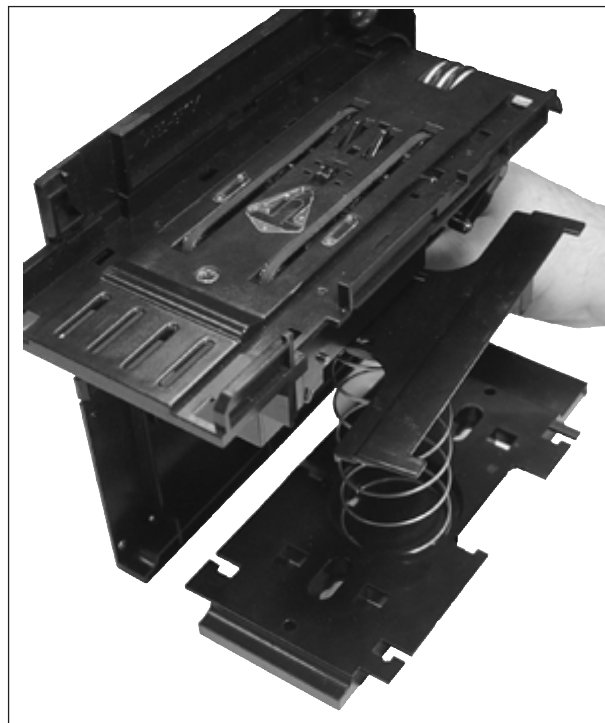

- 12.** Pull the stacker tray forward to release it.

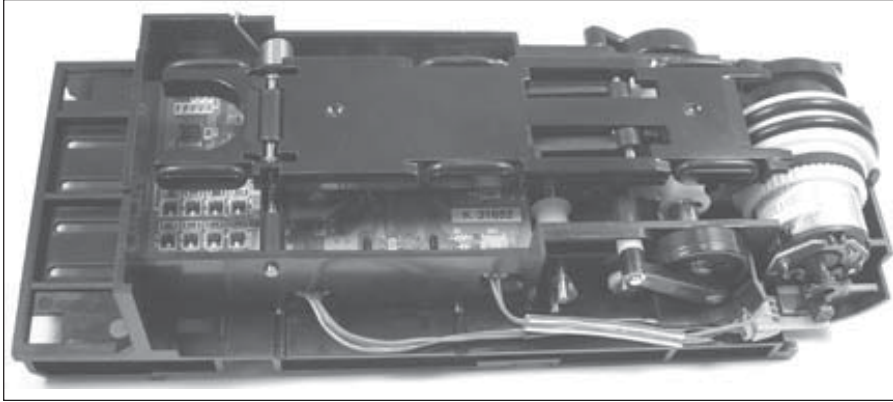

13. To remove the lower circuit board:

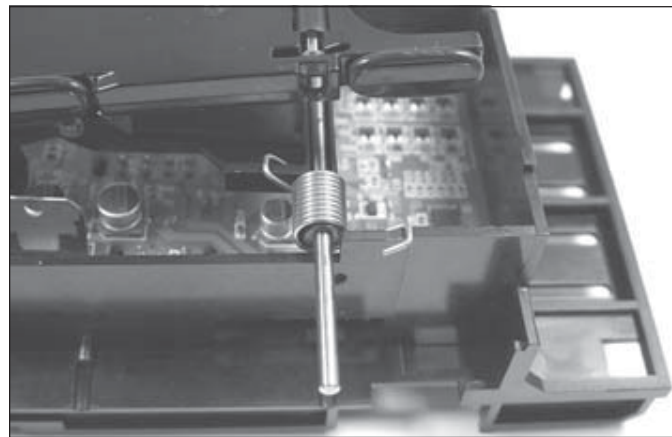

13a. Remove the pin from the stacker.

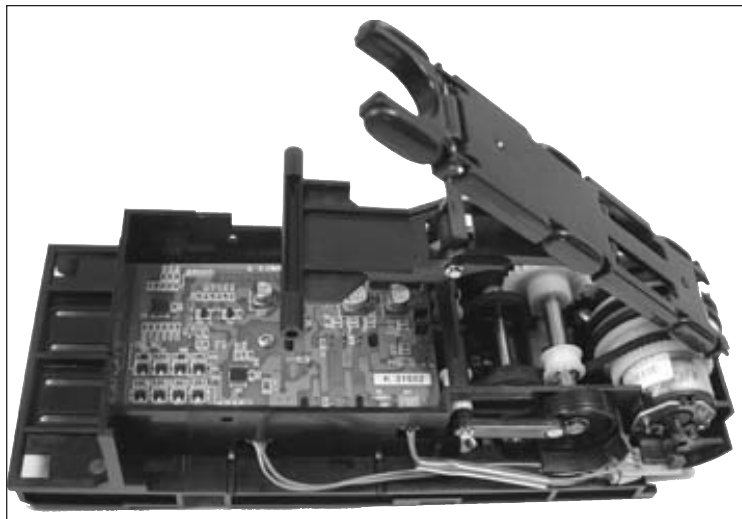

13b. Lift the stacker to expose the circuit board. Disconnect the two harnesses going to the circuit board.

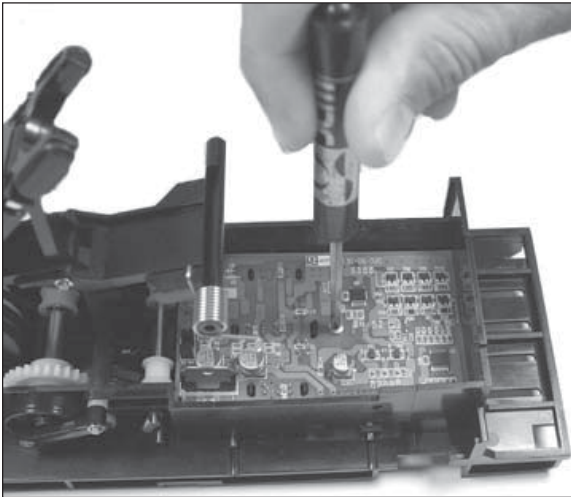

13c. Use the Phillips head screwdriver to remove the screw securing the circuit board.

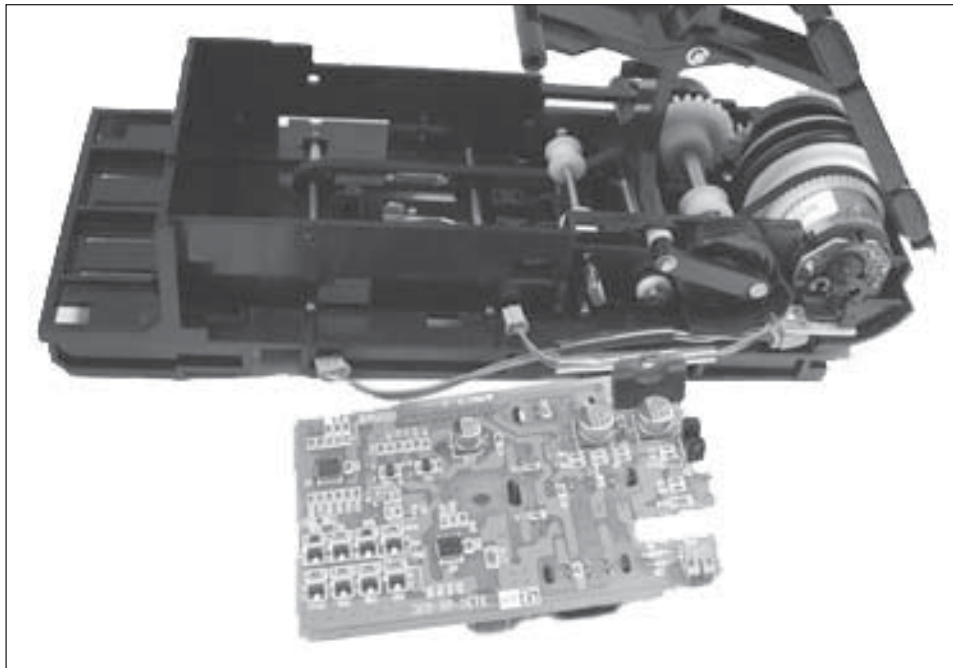

14. Lower circuit board removed.

REFERENCE NOTES: Spring orientation

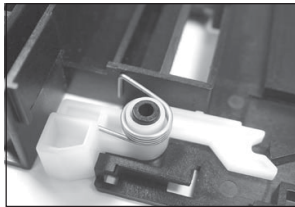

Spring orientation on validator cover release.

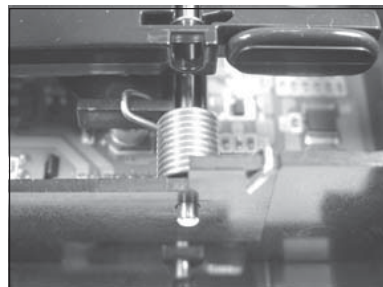

Spring orientation on stacker lever pin.

Calibration and Testing

To perform these calibrations, it is necessary to have Kit No. 701-000086

Connecting the EB-100 to a PC.

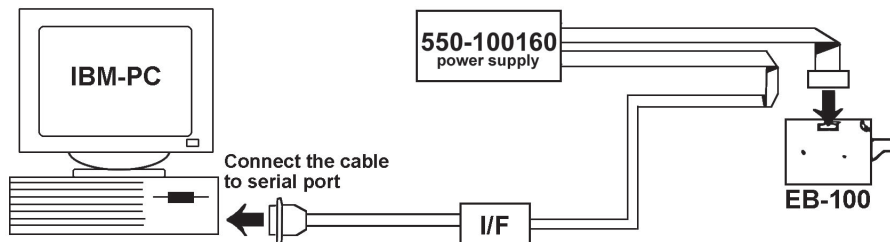

Tools required for calibration

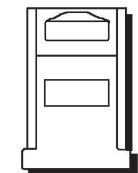

White Paper
501-000027



Black Paper
501-000028

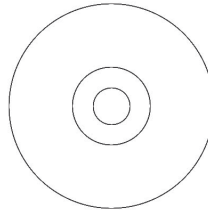

Calibration Software
960-000059



MAG test tool
501-000042

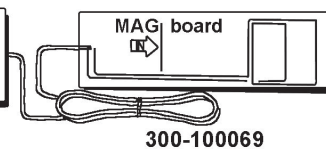

MAG board
300-100069

Dip Switch Settings for the EB-100

(Unless otherwise noted, all references to Dip switches refer to the switches on DSW-1)

When the test mode starts, the red and green LEDs on the front display will light up. This is the test mode standby state. Sensor adjustments and selection of various performance tests are also performed in this mode.

If both the red and green LEDs do not light up, check the Dip switch settings. If the Dip switches are set correctly, check the EPROM and CPU board.

1. Set Dip switch DSW-1 #8 to ON.
Set Dip switches #1 to #7 OFF.
2. Apply power. Red LED lights up and green LED flashes.
3. Set the appropriate Dip switch ON (Page 19). Turn Dip switch #8 OFF to start test.
4. Set Dip switch # 8 to ON to end test.

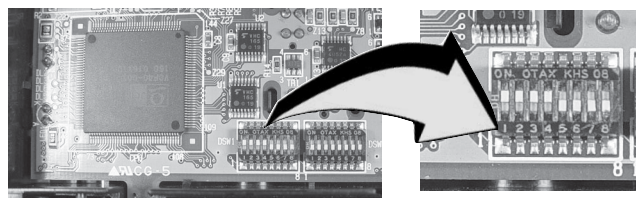

Sensor Locations

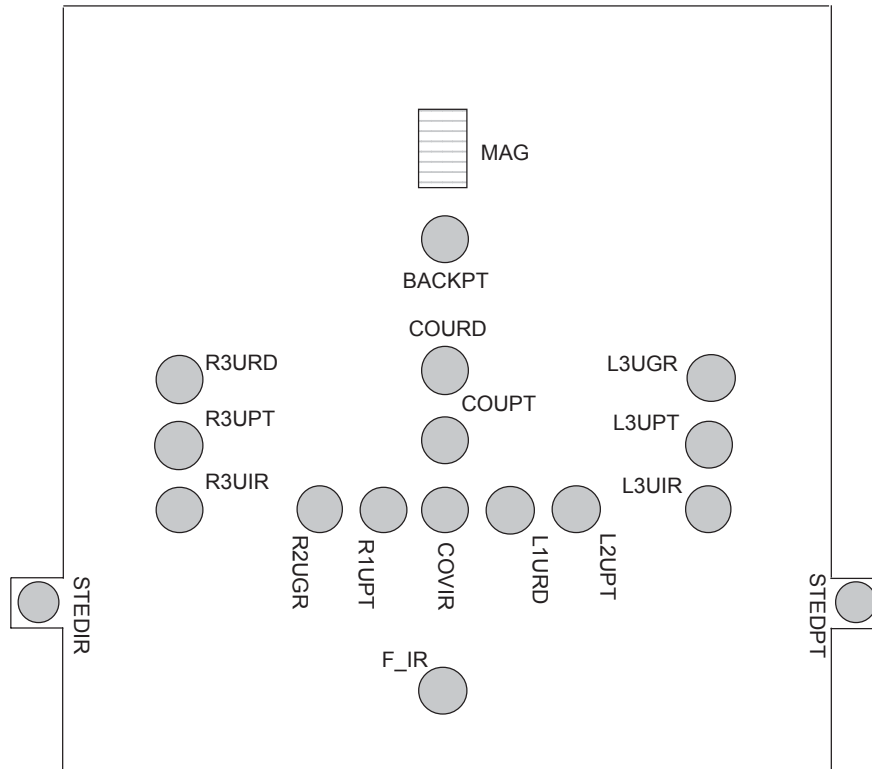

Upper Circuit Board

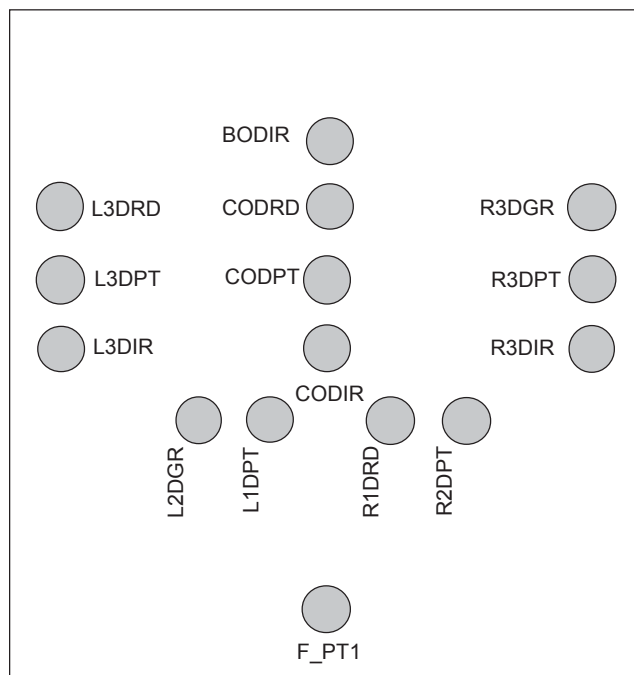

Lower Circuit Board

Sensor Adjustment

Be aware that even though the EB-100 sensors are self-adjusting, this program must be used when either circuit board is replaced, or the EPROM is changed, or the lenses are cleaned.

Installing the software

When the EB-100 CD (Part No. 960-000059) is placed in the CD drive, the first window to appear indicates files are being copied from the CD to the hard disk.

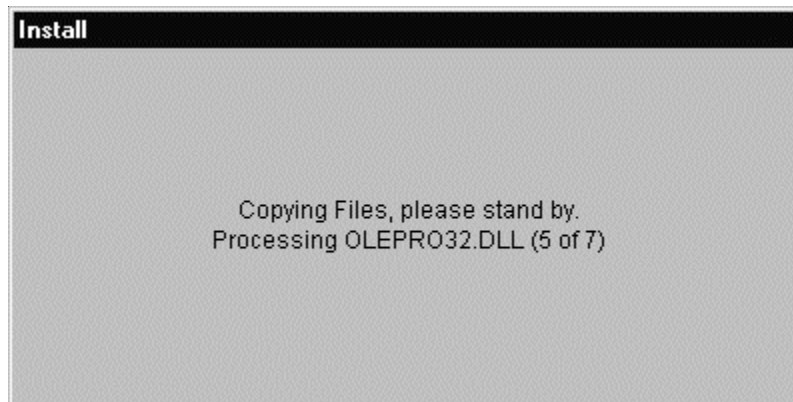

After those files are copied, the opening window appears.

This window warns that the program cannot be loaded if other applications are running. If you click on "Exit Setup," the program will delete the files it loaded and close down. If you click on "OK", the next screen shows the location where the program will be installed on the hard drive.

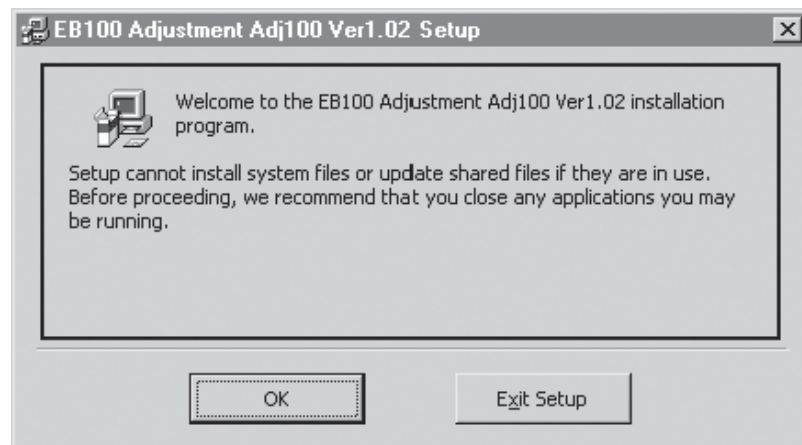

If you choose to change the location, click on “Change Directory” and indicate the new location. Once again, you have the option to “Exit Setup”.

Click on the large icon to begin loading the program.

At the end of the installation process, a message on the screen indicates the program is installing the adj100 icon on the desktop.



Adj100

Connect the EB-100 to the PC using the RS-232C cable on the power supply.

Set Dip switch SW1-8 ON.

Apply power to the unit.

Using the adjustment software

- Double click the Adj100 icon
- The main screen will appear:

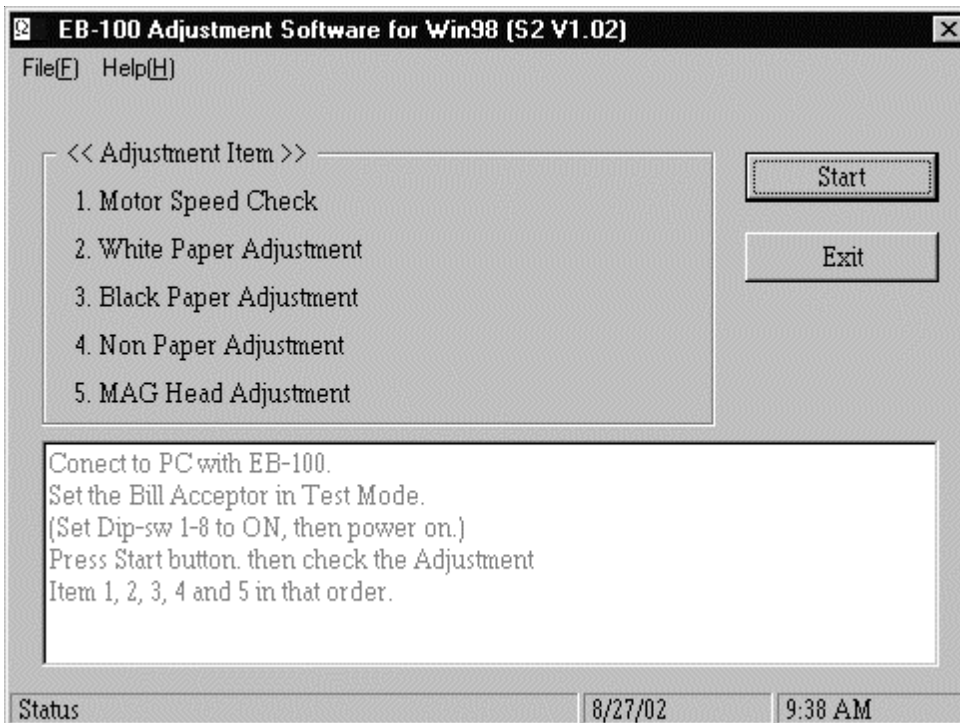

To begin the adjustment procedure, click on the Start button.

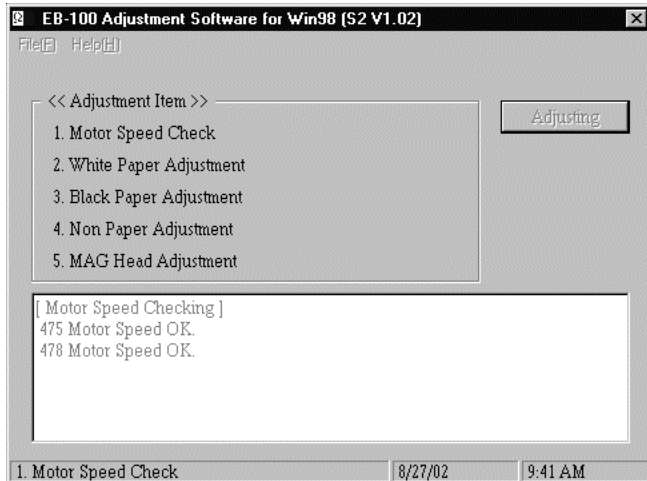

NOTE: To bypass the Motor Speed Check, click on Help, then click on Options. If there is a check mark beside Motor Speed Check, remove it.

When the motor speed test is completed, message No. 2 appears. Open the validator and insert the White reference paper, then close the validator. Click on "Yes".

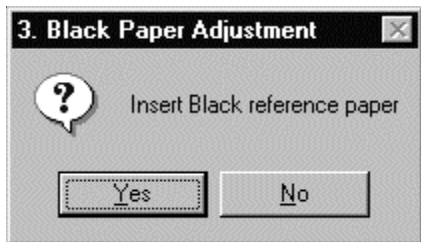
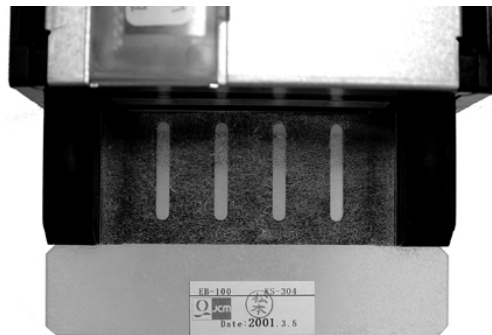
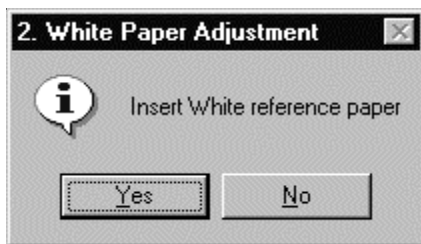

When the White Paper Adjustment is finished, message No. 3 appears. Open the validator and replace the White reference paper with the Black reference paper. Close the validator and click on "Yes".

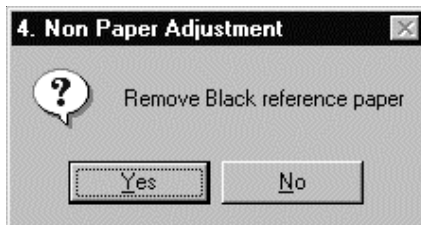

When the Black Paper Adjustment is completed, message No. 4 appears. Open the validator and remove the Black reference paper, then close the validator. Click on "Yes".

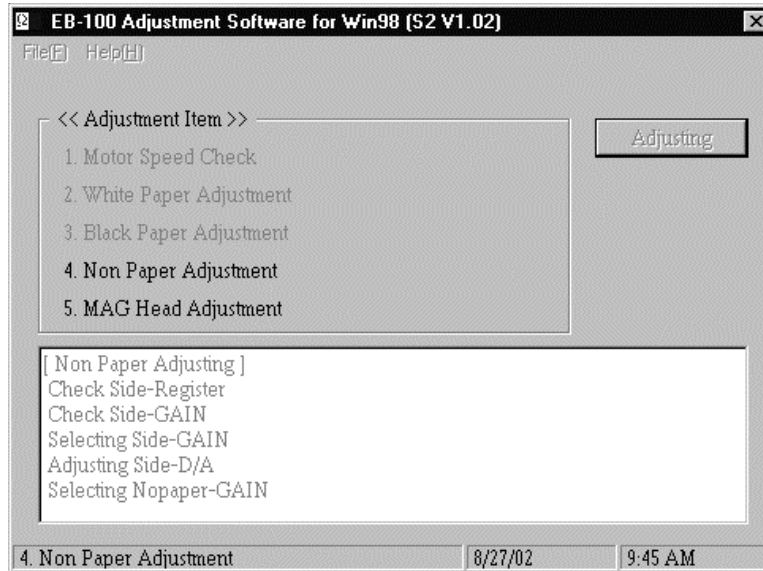

When the Non-paper Adjustment is finished, message No. 5 will appear.



Attach the two-wire harness from the MG-03 (Part No. 501-000042) to the Mag Head Test board (Part No. 300-100069). Apply power to the MG-03.

Open the acceptor and insert the Mag Head Test board approximately as shown. Close the validator, click on "Yes" and observe the figures on the screen.

It may be necessary to move the Mag Head board in or out slightly to get the peak number which should be over 70. Click on the confirm icon to end the test.



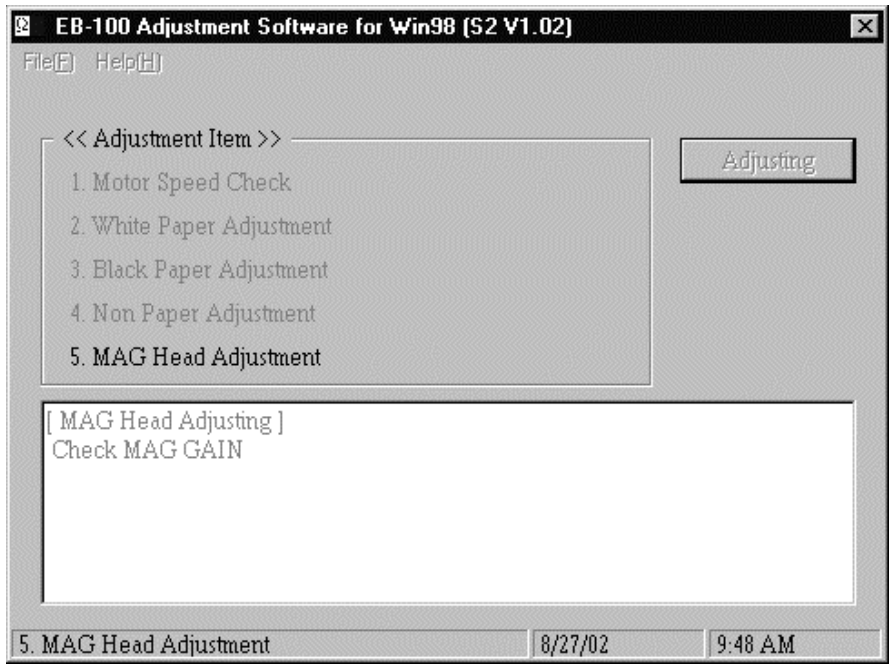
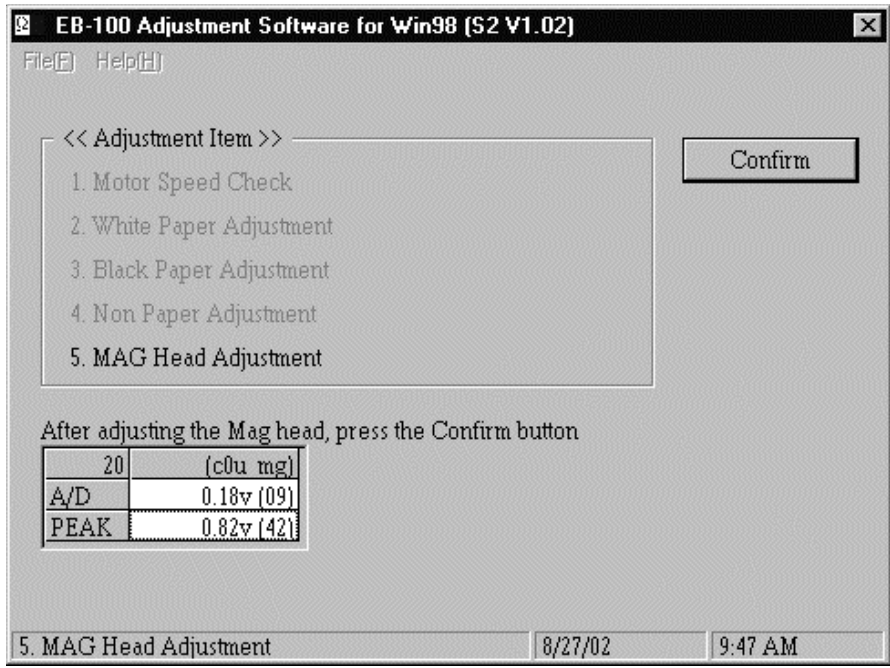

When all adjustments are completed, click "Yes" to write them to the acceptor.

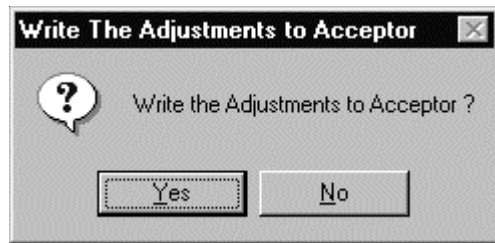

When finished, click on the OK icon and return the EB-100 to normal operating settings.



Bill Jams

There are only three (3) places on the EB-100 where a bill jam can occur: the transport, the turn guide, and the stacker inside the cash box. When a bill jam does occur, observe the red flashing LED above the bill acceptor slot. The number of flashes will indicate the jam location. The timing of the flashes will indicate whether it is a System Code or an Error Code. The System Codes flash for a full second, the Error Codes flash for 0.4 of a second.

To Remove a Bill Jam

1. Open the transport cover to see if the bill jam is in the transport. If the bill is there, remove it and close the transport cover.
2. Lift the turn guide shaft to open the turn guide to see if the jam is in the turn guide. If the bill is there, remove it and close the turn guide.
3. Open the front and rear box covers if the jammed bill is not in the transport or turn guide. Remove the jammed bill from the stacker, and close the front and rear box covers.

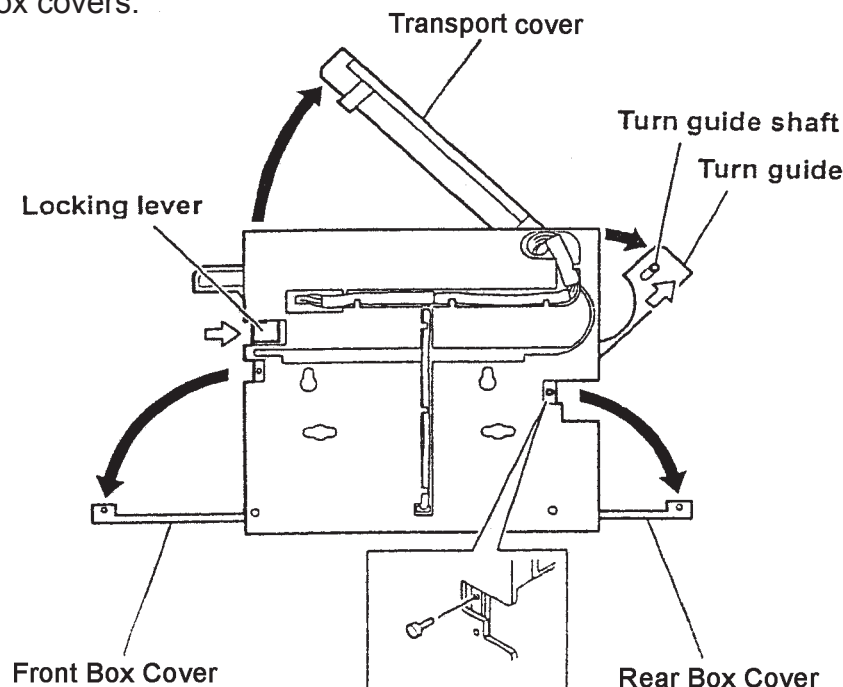

System Error Codes

The blinking red LED on the bill insertion indicates the problem.

Count the number of flashes, and check the table below to determine the cause.

# LED Flashes	Description	Solution
1	Stacker Full	Remove bills from stacker
2	Stacker Jam	Check inside stacker Check stacker sensor
3	Transport Path Jam	Check near stacker lever
4	Transport Path Jam	Check transport
5	Motor Speed Error	Check for foreign substance on transport Check operation of motor
6	Motor Stop Error	Check for bills on transport Check operation of motor
7		Reserved
8	Reserved	Reserved
9	Reserved	Reserved
10	Stacker Door Open	Close stacker door
11	Reserved	Reserved
12	Fraud Error	Sensor timing error
13	Reserved	Reserved
14	Reserved	Reserved
15	Reserved	Reserved

LED Flashing timing

The red LED flashes for 1 second, then is off for 0.4 second.

There is a 2.5 second interval between the series of flashes.

Reject Codes

The blinking red LED on the bill insertion indicates the problem.

Count the number of flashes, and check the table below to determine the cause.

#LED Flashes	Description
1	Bill insertion
2	Magnetic sensor
3	Bill jam in transport
4	Optical sensor
5	Transport
6	Denomination
7	Optical sensor
8	Optical sensor
9	INHIBIT command
10	Host command
11	Stacker lever
12	Stacker assembly
13	Roll length
14	Optical sensor
15	Optical sensor

IMPORTANT: When bills are frequently rejected, clean the transport. With the power turned off, open the transport cover. Use a soft cloth with water and a non-abrasive soap solution to clean the upper and lower sensor covers and belts.

LED Flashing timing

The red LED flashes for 1 second, then is off for 0.4 second.

There is a 2.5 second interval between the series of flashes.

Test Mode

(see instructions on page 10)

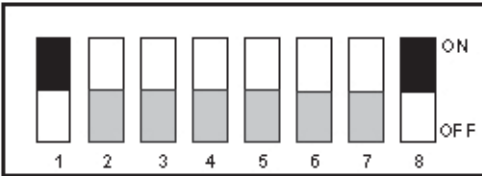

Motor forward test
(Rotates motor in the forward direction)

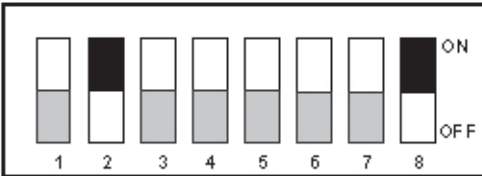

Motor reverse test
(Rotates motor in a reverse direction)

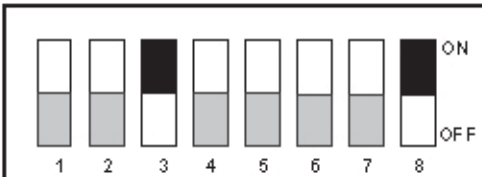

Stacker test
(Moves the stacker plate up and down)

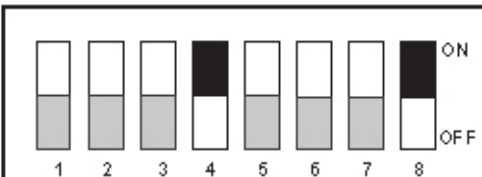

Burn-in (aging) test
(Repeats complete cycle for errors)

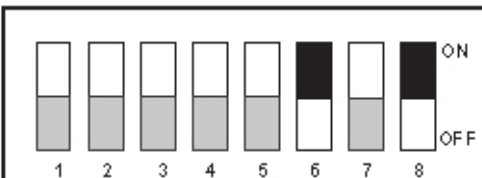

Acceptor sensor test
(see Acceptor Sensor Test Detail, page 21)

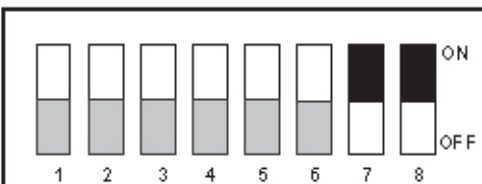

Stacker sensor test
(see Stacker Sensor Test Detail page 21)

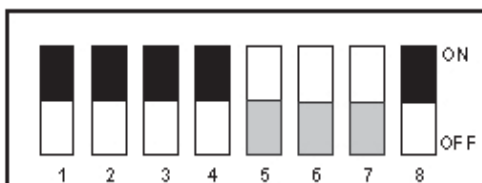

Bill receiving test
(Insert various bills to validate acceptance)

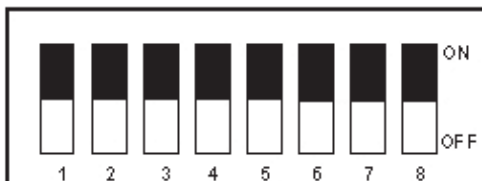

Dip switch test
(see Dip Switch Test Detail page 21)

EB-100 Test Mode (Cont.)

Acceptor Sensor Test Detail (DS-1)

1	2	3	4	5	6	7	8	Sensor ID
O	X	X	X	X	X	X	X	PSF (Entrance)
X	O	X	X	X	X	X	X	PSB (Line 5 Right)
X	X	O	X	X	X	X	X	PSMR (Line 1 right)
X	X	X	O	X	X	X	X	PSML (Line 1 Left)
X	X	X	X	O	X	X	X	PSC (Line 3 Center)
X	X	X	X	X	O	X	X	PSR (Line 3 Right)
X	X	X	X	X	X	O	X	PSL (Line 3 Left)

O = ON, X = OFF

Stacker Sensor Test Detail (DS-1)

1	2	3	4	5	6	7	8	Sensor Code
O	X	X	X	X	X	X	X	PSI (LEV1: Green LED turns on when note detected)
X	O	X	X	X	X	X	X	PSO (LEV2: Green LED turns on when note detected)
X	X	O	X	X	X	X	X	HOME (Green LED turns on when pusher position is home)
X	X	X	O	X	X	X	X	DOOR (Green LED turns on when stacker door is open)
X	X	X	X	O	X	X	X	FULL (Green LED turns on when micro switch is on)
X	X	X	X	X	O	X	X	ENCODER (Green LED turns on when encoder sensor closes)
X	X	X	X	X	X	O	X	Reserved

O = ON, X = OFF

Dip Switch Test Detail (DS-1 and DS-2)

Change Dip switch position following turn on. When green LED is on, then OK.

DSW-1

DSW-2

1	2	3	4	5	6	7	8	1	2	3	4	5	6	7	8	Turn
O	O	O	O	O	O	O	O	O	O	O	O	O	O	O	O	1: Green flash, Red on
O	X	O	X	O	X	O	X	O	X	O	X	O	X	O	X	2: Green flashes
X	X	X	X	X	X	X	X	X	X	X	X	X	X	X	X	3: Green LED turns on

O = ON, X = OFF

Exploded View - Top

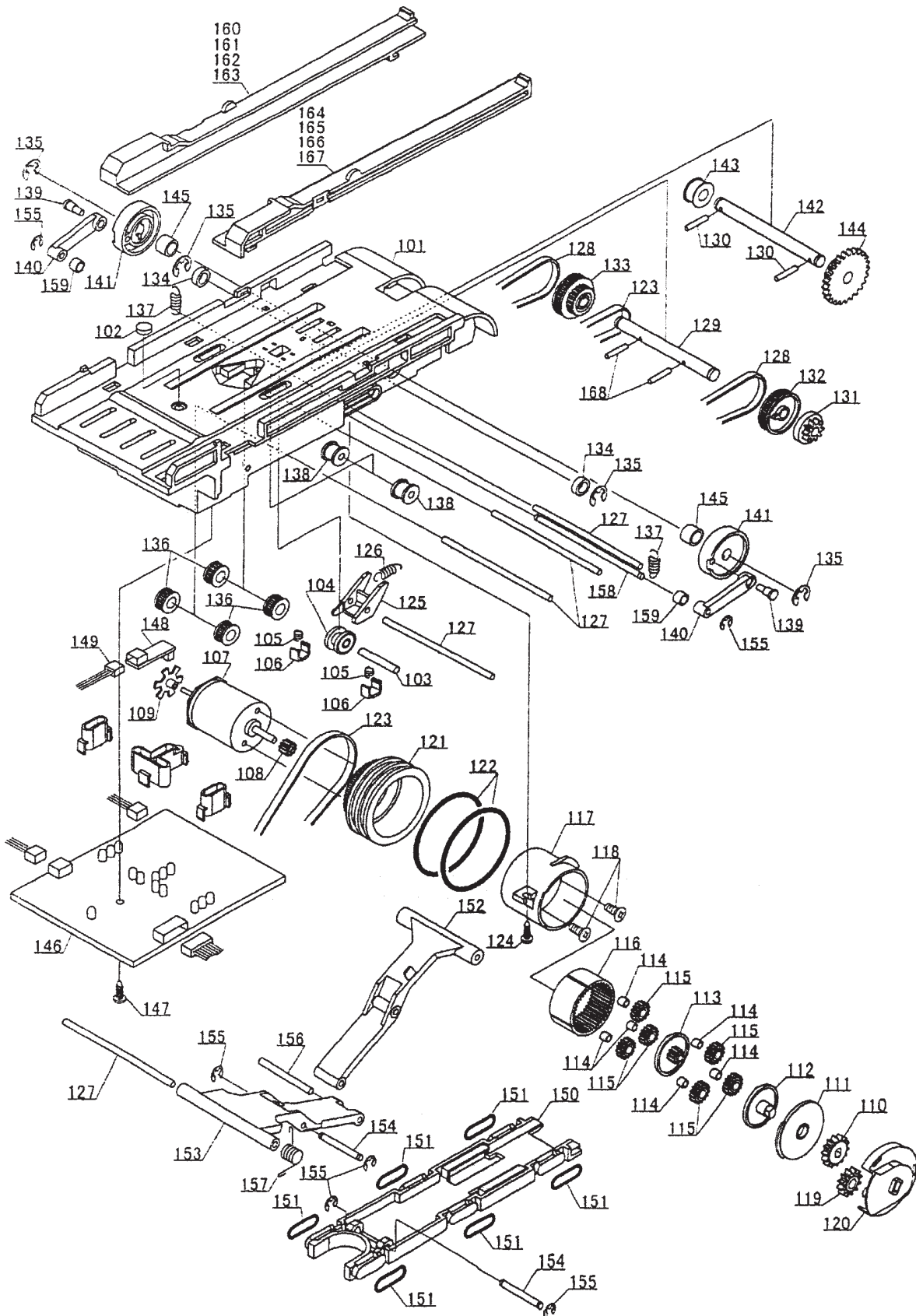

Parts List

No.	EDP No.	Part No.	Description	Qty.
101	074322	0666AS0102B	Down guide Assy.	1
102	066043	0643RE0116B	Sensor Guide	1
103	055128		Ø3 x 20 Parallel Pin	1
104	066035	0643RO0101	Conveying Roller	7
105	066078	0643CS0103	MAG Roller Spring	2
106	072389	0666RE0119	Roller Guide	8
107	072407	JC-2217	Motor Assy.	1
108	072334	0666GE0103	Gear 2	1
109	072399	0666RE0118	Encoder	1
110	072335	0666GE0104	Gear 3	1
111	072388	0666RE0118	Gear Box 3	1
112	072398	0666RE0128	Rotor Plate (Arm)	1
113	072339	0666GE0108	Rotor Plate (Gear)	1
114	072352	0666CO0101A	Collar	6
115	072333	0666GE0102	Gear 1	6
116	072338	0666GE0107A	Gear 6	1
117	072387	0666RE0117A	Gear Box 2	1
118	005332		M3 x 5 Flat Head Screw	2
119	072336	0666GE0105	Gear 4	1
120	072386	0666RE0116	Gear Box 1	1
121	072340	0666PU0103B	Idler Pulley 1	1
122	066086		O Ring P36	2
123	072356	88MXL W=3.2 V	Timing Belt	1
124	071182		2 x 10 P Tite Bind Screw	1
125	072390	0666RE0120	Conveying Lever	1
126	066087		Tension Spring E501	2
127	072346	0666SH0105A	Pulley Shaft 2	6
128	072357	110MXL W=3.2 V	Timing Belt	2
129	072343	0666SH0102	Pulley Shaft	1
130	038938		Ø2 x 10 Parallel Pin	2
131	072337	0666GE0106	Gear 5	1
132	072411	0666PU0101	Driving Pulley 1	1
133	072412	0666PU0102	Driving Pulley 2	1
134	050646	0899RE0308	Bearing 3	2
135	003708		E type Crip Ø4	4
136	072410	0666PU0104	Idler Pulley 2	4
137	039365		Tension Spring E561	7
138	052502	0943RE0520	V Roller 1	2
139	072351	0666ST0101B	Arm Stud	2

No.	EDP No.	Part No.	Description	Qty.
140	072379	0666RE0109	Pusher Arm 3	2
141	072380	0666RE0110A	Pusher Arm 4	2
142	072342	0666SH0101A	Gear Shaft	1
143	072341	0666RO0101	Roller	1
144	072332	0666GE0101	Clutch Gear	1
145	052561	0943RE0508	Bush Ø6B	2
146	070787	3130-06-02C-01A	LED Substrate Unit	1
147	063250		2.6 x 6 Tite Bind Screw	4
148	057186	990-03-23	Photo Interrupter Unit	1
149	072013	3130-05-02B	Encoder Harness	1
150	072376	0666RE0106	Pusher Plate	1
151	034864		O Ring P11	6
152	072377	0666RE0107	Pusher Arm 1	1
153	072378	0666RE0108	Pusher Arm 2	1
154	072350	0666SH0109	Arm Shaft 2	2
155	003705		E Type Clip Ø2	9
156	072362		Ø3 x 25 Parallel Pin	2
157	072409	0666KS0101	Pusher Spring	1
158	072345	0666SH0104	Arm Shaft 1	1
159	072358		C304 Spacer	2
160	072405	0666RE0306	Side Block (73)-L	1
161	072401	0666RE0302	Side Block (67)-L	1
162	072403	0666RE0304	Side Block (71)-L	1
163	072331	0666RE0308	Side Block (77)-L	1
164	072404	0666RE0305	Side Block (73)-R	1
165	072400	0666RE0301	Side Block (67)-R	1
166	072402	0666RE0303	Side Block (71)-R	1
167	072406	0666RE0307	Side Block (77)-R	1
168	075967		Ø2 x 10 Spring Pin	2
201	072355	0666PT0102A	Switch Plate	2
202	045120		Nylon Rivet NRP-355	1
203	072374	0666RE0104	Side Guide R	1
204	070788		Door-Full-Sens Board	1
205	072014	3130-05-03C	CPU-LED Harness	1
206	071928		LED 2 Sens Board	1
207	072385	0666RE0115A	Lock Lever	1
208	072373	0666RE0103	Side Guide L	1
209	072375	0666RE0105	Turn Guide	1
210	072347	0666SH0106A	Turn Guide Shaft	1
211	074395	Ø2.4 x 7 x1.6	Flat Spacer	1
212	072391	0666RE0121A	Stacker Lever	1

No.	EDP No.	Part No.	Description	Qty.
213	006371		Ø3 Grooved Washer	1
214	034851	RE0-06	Roller	2
215	072392	0666RE0122	Pusher Lever	1
216	072012	3130-05-01A	Power Harness	1
217	072348	0666SH0107	Stacker Lever Shaft	1
218	071183		M2.3 x 4 Pan with Washer	2
219	075183	C-125	Pusher Spring	8
220	074315	0666AS0101B	UP Guide Assy.	1
221	067412		Three Terminal Regulator	1
222	066085		O Ring P5	6
223	072349	0666SH0108	Roller Shaft	3
224	067465	0659RE0112	ROM Cover Wide	1
225	072354	0666PT0101A	Up Guide Cover	1
226	072344	0666SH0103A	Lock Shaft	1
227	072397	0666RE0127	Lock Guide	1
228	072393	0666RE0123	LED Cover	1
229	072384	0666RE0114A	Box Cover 2	1
230	070786		CPU Substrate Unit	1
231	062438	M27C2001-10f1	ROM	1
232	072381	0666RE0111	Down Plate	1
233	072353	0666CS0101	Box Spring	1
234	072382	0666RE0112	Box Plate	1
235	072383	0666RE0113A	Box Cover 1	1



925 Pilot Road, Las Vegas, Nevada 89119

Office: (800) 683-7248, Tech. Support: (702) 651-3444, FAX: (702) 651-0214

E-mail: techsupport@jcm-american.com

<http://www.jcm-american.com>