



Office: (800) 683-7248 **Technical Support:** (702) 651-3444 **FAX:** (702) 651-0214
E-Mail: techsupport@jcm-american.com **Web-Site:** www.jcm-american.com

Thermal Printer Series - 100

JCM part No. 960-000038

Table of Contents

Introduction	1
Model Classification	2
General Specifications	3
Dip Switch Settings	5
Thermal Paper Specifications	6
Photo of Printer	9
Pin Outs	10
Installation	11
Typical Mounting Holes	11
Operation	12
Calibration	12
Troubleshooting	14
Cleaning	17
System Logic Diagram	18
Illustrated Parts Breakdown	20
Parts List	21

Introduction

The Thermal Security Printer – TSP-01

The TSP-01 is a multi-purpose printer that is suitable for any application requiring quality printing ability.

JCM provides the thermal paper specifications for optimum performance (see page X), while allowing the customer the freedom to create a unique 4-color design on the top surface. The thermal side is reserved for the barcode created by the thermal printer, which is read by bill acceptors and other barcode reading devices. The TSP-01 uses pre-cut, pre-printed paper that offers the following advantages:

- No curled paper or tickets from the end of a roll that could cause a jam when inserted into a bill validator.
- No wasted paper such as found when using roll or fanfold thermal paper.
- No cutting device necessary within the printer that can cause failures or malfunctions during operations.

- No complex paper loading procedures such as found with rolled or fanfold paper.
- Customers can reload the pre-cut paper at any time to the maximum quantity.

Read-After-Write (RAW)

JCM's RAW feature verifies the accuracy and quality of the printed ticket prior to dispensing it. If the printer senses a problem, it stores the ticket internally, and sends an error message to the host machine. The printer then attempts to reprint the ticket.

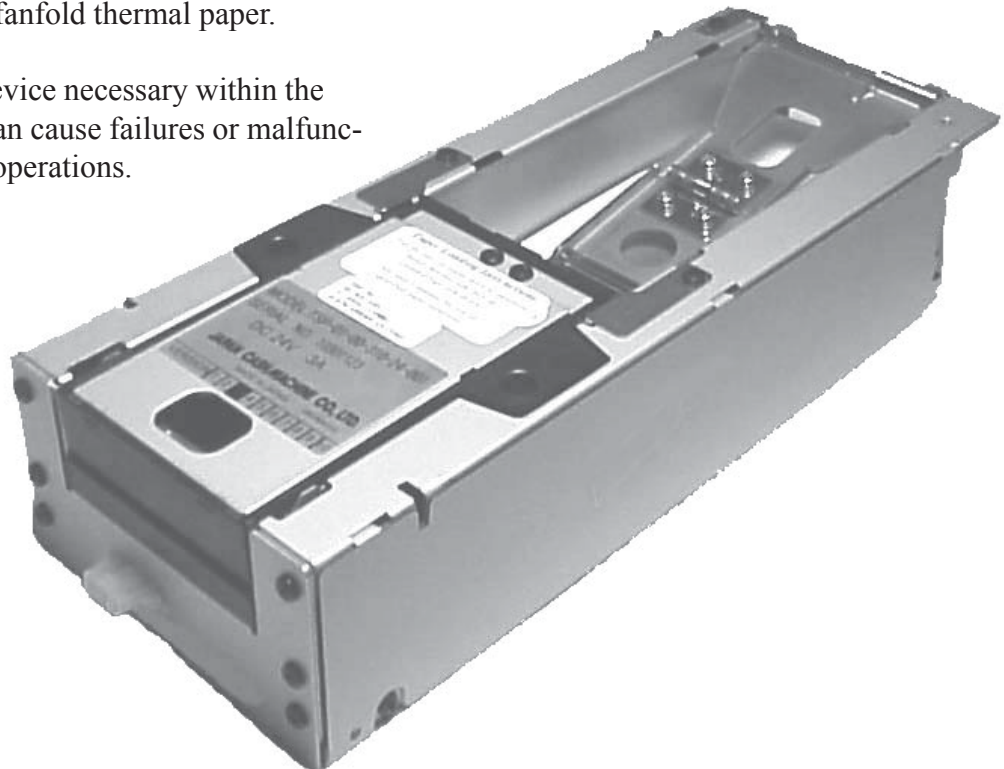

Model Classification

How to read the Model Classification Number

CATEGORY 813 TSP PRINTER

TSP – X X – X X – X XX – X X –XXX
(1) (2) (3) (4)(5)(6) (7) (8)

(1) TSP Thermal Security Printer

(2) CPU

01 4 MB EPROM w/barcode verify

(3) Mounting & Cable Bracket configuration

00	No mounting brackets,	no cabling.
01	No mounting brackets,	024 cable output
02	Front hook bracket, long rear bracket;	024 cable output
03	Flat front bracket, short rear bracket;	024 cable output
04	No mounting brackets;	ribbon cable output
05	No front bracket, small rear bracket;	ribbon cable output
06	No front bracket; small rear bracket;	ribbon cable w/header

(4) Paper capacity

3	250 notes
5	500 notes

(5) Paper size

1	65 mm x 156 mm (US \$)
---	------------------------

(6) Faceplate

0	No Faceplate
---	--------------

(7) Type of Software

03	ID-003 JCM Standard
24	ID-024 IGT Netplex

(8) Other Options

001 – Standard configuration

Examples:

TSP-01-05-310-03-001

Printer model 01 with no front bracket, small rear style mounting, 003 ribbon style cable; 250 note capacity;

USA size paper; no faceplate; ID-003 software, no special options.

General Specifications

Outside Dimensions

Width : 113 mm (4.448 inches)
Height : 67.5 mm (2.657 inches)
Depth : 279.4 mm (11 inches)

Weight

1.5 Kg, or 3.3 lbs

Power Requirements

DC 24V (+10%, -5%)
3A (50% print ratio)

Paper Hopper Capacity

250 standard.
Optional hopper extensions
for 500 pre-cut pieces available

Recommended Thermal Paper

Part No. KF50 - HDA or compatible

NOTE: Using other paper may affect the quality and thermal printer head longevity. Contact your JCM account representative for a list of qualified suppliers.

Paper Dimensions

66 mm Width
156 mm Length

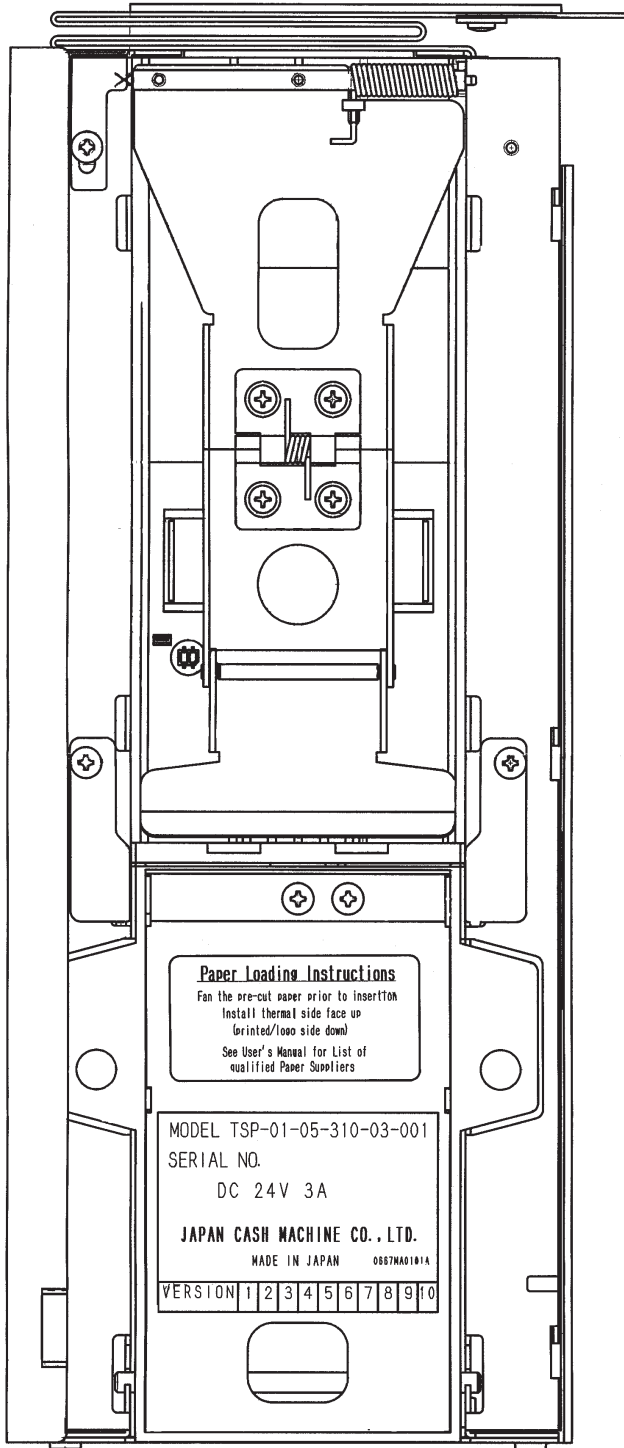

General Specifications: Cont'd

Paper Rejection Function - .

R.A.W - Read After Write

When sensors detect double paper, or a barcode print failure condition, the paper is sent to an internal reject area and an error code is sent to the host application.

The reject area has a capacity of 5 sheets.

Installation

Indoors

No Sunlight

A lengthwise installation angle between 0° and 45° degrees

Operating Environment

Temperature : +5°C ~ +45°C

Humidity : 10 ~ 90% RH (no condensation)

Storage Environment

Temperature : -25°C ~ +70°C

Humidity : 10 ~ 90% RH (no condensation)

Types of Sensor Detectors

Paper Out Sensor

Paper Near Out Sensor

Paper Dispensed Sensor

Paper Reject Sensor

Double Paper Sensor

Barcode Read Sensor

Printing Method

Thermal line dot method

Dot Density

8 dots / mm

Effective Print Dot Area

480 dots wide

1200 dots long

Effective Print Area

60 mm X 150 mm

Maximum Print Speed

75 mm / second

Thermal Print Head Rating

Pulse Life : 50 million pulses

Abrasion Life : 50 km

Handling Time

From receipt of data to full dispense : ~ 5 seconds

Paper pick up time (from box to head) : ~ 1 second

Print time : ~ 2 seconds

Dispense time (from print finish to full dispense) : ~ 2 seconds

Dip Switch Settings

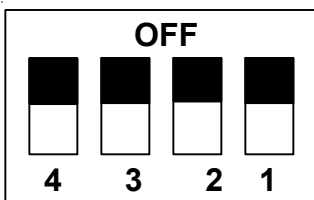

Normal Operating Setting - This is the default setting for normal communication via the host application.

Dip Switch #1: Off = Barcode check
 On = No barcode check

Others are default to OFF position

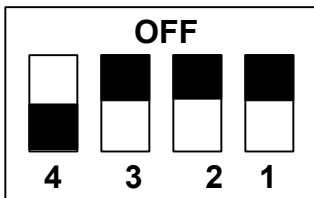

Coupon Print Test - Will print a ticket and check the barcode. If there is something wrong with the barcode, VOID will be printed on the ticket and it will be transported to the reject area.

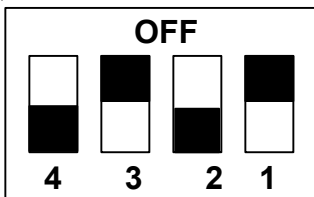

Print Bar Sensor Signal and Data - A barcode ticket is printed. The sensor signal and data are printed on the following piece of paper. This is used to make sure barcode and transparency sensors are adjusted properly.

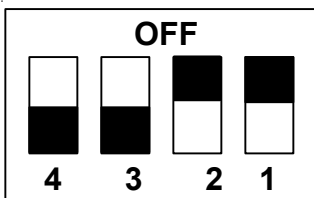

Print Test pattern and Version Information - Print a test pattern, model name and version number. This feature is useful for quickly checking print quality.

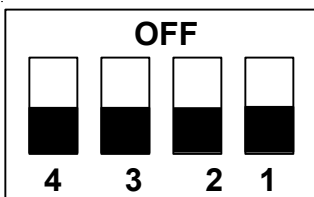

Adjust Barcode and Transparency Sensors - To be used when attempting to use the Sensor Adjustment procedure.

NOTE: Dip switches must be set with the power OFF. W#hen power is turned ON, the operation begins.

Thermal Paper Specifications

1. Overview

This specification is for thermally coated tickets designed for use with the JCM TSP-01 thermal printer.

2. General Characteristics

- 2.1 Tickets to be pre-cut sheets.
- 2.2 Ticket edges must be smooth to prevent double feeding.
- 2.3 Ticket size: 65 ± 1 mm x 156 ± 1 mm.
- 2.4 Tickets to be supplied in bulk stacks of 200.
- 2.5 Each stack shall have a tear off band.
- 2.6 Tickets must be processed and cut in a manner that minimizes paper dust.

3. Thermal Paper Specification

ITEM	SPEC.
Weight	g/m ² 102 Avg
Caliper	μ 114 Avg (4.5 mils)
Brightness	% 89 Avg
Smoothness	sec. 2000 Avg
Image Colors	Black
Initial Activation Temp.	° C 74 ± 5 O.D. = 0.2
Effective Activation Temp.	° C 83 ± 5 O.D. = 0.8
Optimum Activation Temp.	° C 90 ± 5 O.D. = 1.2
Resistance of Oils	Very Good
Resistance of Alcohol, Solvents	Very Good
15 Hr. Water Immersion	Very Good

4. Paper Curl

The deformation (curl and warp) of papers used for TSP-01 printers is limited as follows. Deformation to be measured after paper has been stabilized for a minimum of 48 hours at $20 \pm 5^\circ\text{C}$, $55 \pm 15\%$ RH.

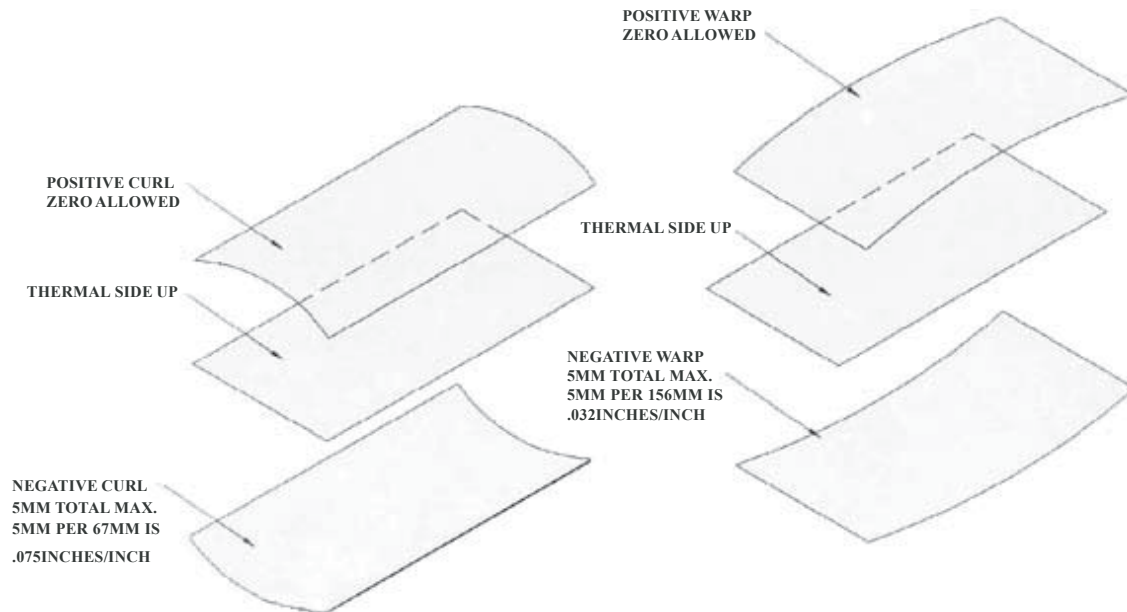

5. Thermal side printing

- 5.1 Ticket shall have the text: “INSERT THIS SIDE UP” preprinted in heat resistant black ink along the 65 mm edge as show in Figure 1. Font size shall be 12 pt.
- 5.2 Lot code, date code or other information identifying the printing date or batch number shall be printed in heat resistant black ink along one of the 65 mm edges as shown in Figure 1. An arrow or other symbol indicating paper grain orientation shall also be included. Font size shall be 4 pt.
- 5.3 No other preprinting is allowed on the thermal side without prior approval of JCM American Corp.

6. Non-thermal side printing

- 6.1 The non-thermal side may be preprinted with multi colored graphic images. All printing on the non-thermal side must be within the area shown in Figure 2.

6.2 It is recommended that non-thermal side printing be pre-approved by JCM American Corp. prior to use to ensure no negative impacts on print or printer reliability.

7. Packaging

7.1 Paper shall be packaged in cartons or boxes designed to protect tickets from damage.

7.2 Packaging must shield tickets from ambient light.

7.3 Package to have “THIS SIDE UP” or similar marking in large bold print to ensure that tickets are shipped and stored horizontally to minimize warp and curl.

7.4 Package to have suggested storage temperature and humidity conditions printed on carton. (Example: Store at 70°F and 50% RH)

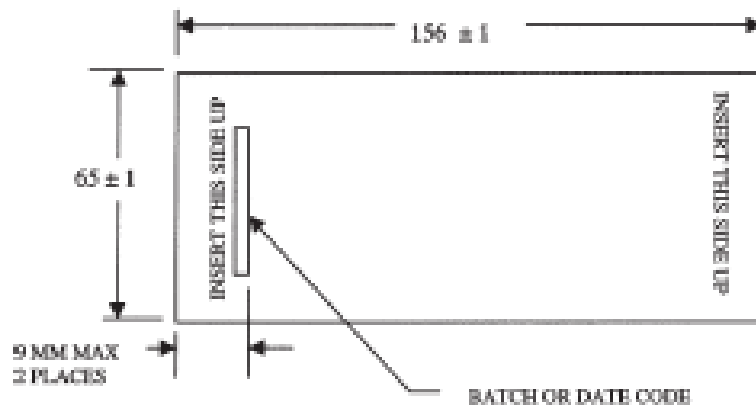

FIGURE 1
THERMAL SIDE PREPRINTING
(DRAWING NOT TO SCALE)

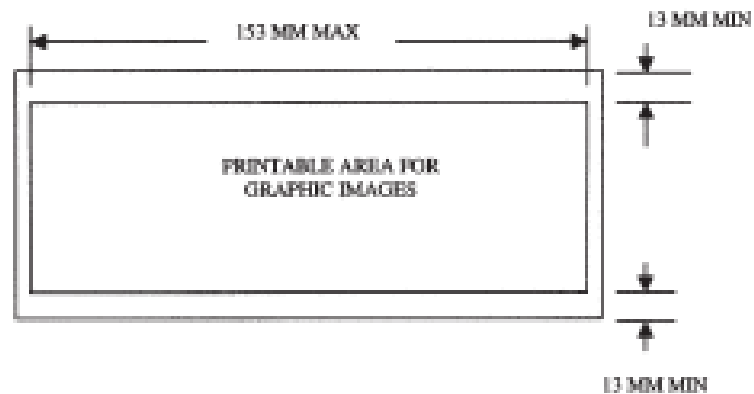

FIGURE 2
NON-THERMAL SIDE PREPRINTING
(DRAWING NOT TO SCALE)

Paper Positioning Guide

Positioning Sensor and Double Paper Sensor

Positioning Sensor

Exit Sensor

Positioning Sensor & Double Page Sensor

Positioning Sensor and Double Page Sensor

Barcode Sensor

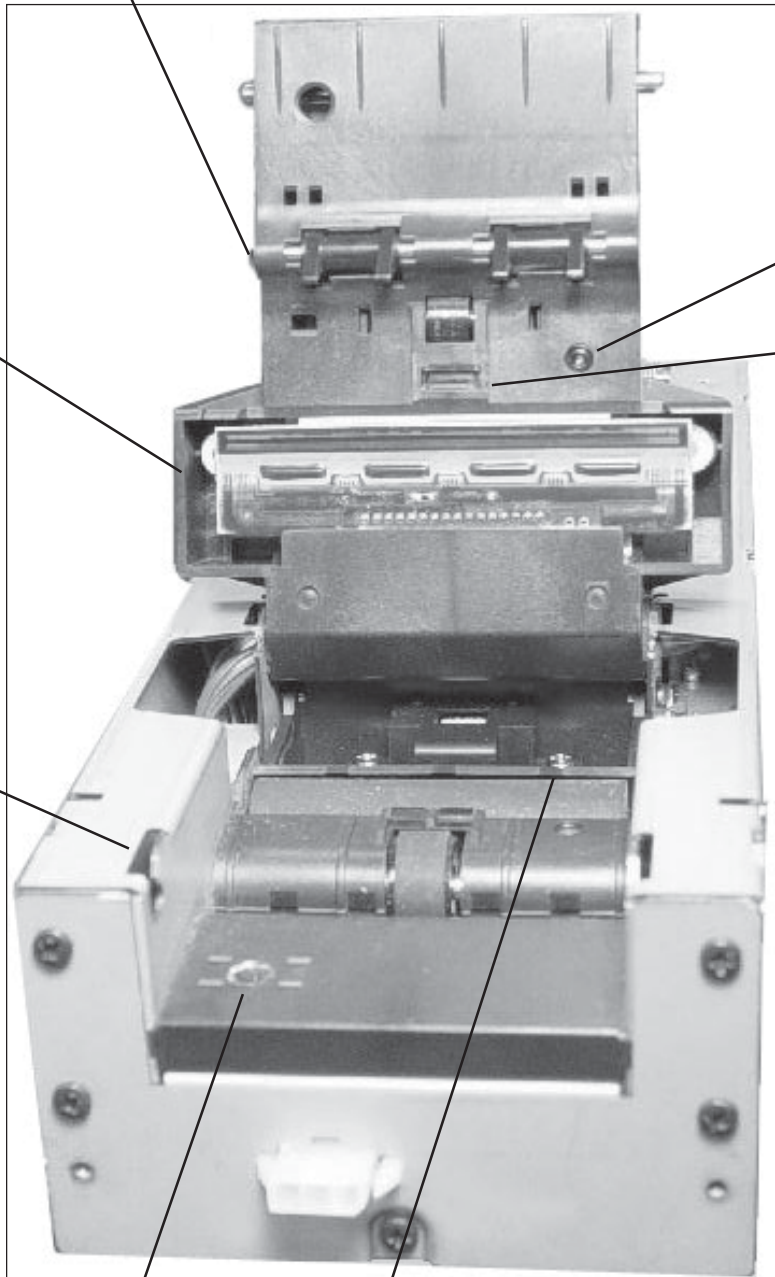

Pin Outs (ID-003)

Green edge of ribbon



FUNCTION	SIGNAL	PIN
	N/C	1
	N/C	2
	N/C	3
	N/C	4
	N/C	5
RS-232CTXD	TXD	6
RS-232CRXD	RXD	7
LED POWER (24V)	RCTR24	8
	N/C	9
LED GND	COM	10
	N/C	11
	N/C	12
RS-232 GND	GND	13
	N/C	14
	N/C	15
	N/C	16
DC24VDC	24V	17
DC24VDC	24V	18
GND	PGND	19
GND	PGND	20

* N/C = Not Connected

Installation

1. Install the printer mounting frame in the host machine using the appropriate mounting holes in the bottom of the frame.
2. Attach the ribbon cable to the host machine.
3. Slide the printer into the frame by pushing in on the arm covering the EPROM. Attach the ribbon cable to the printer before pushing the printer all the way in.

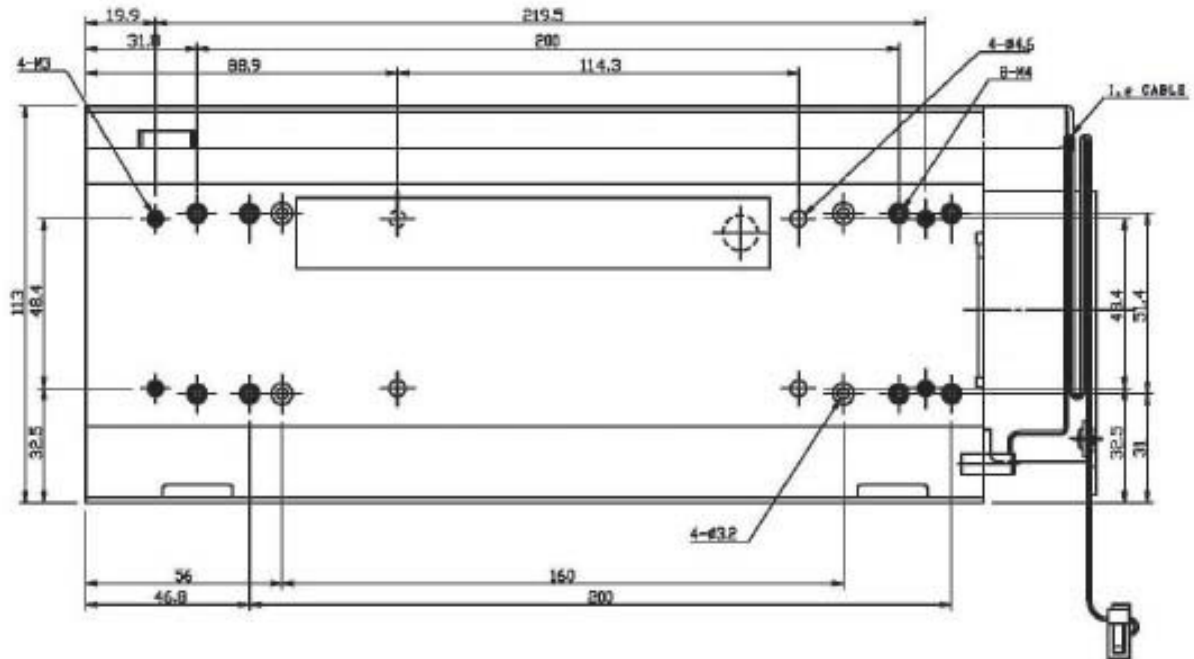
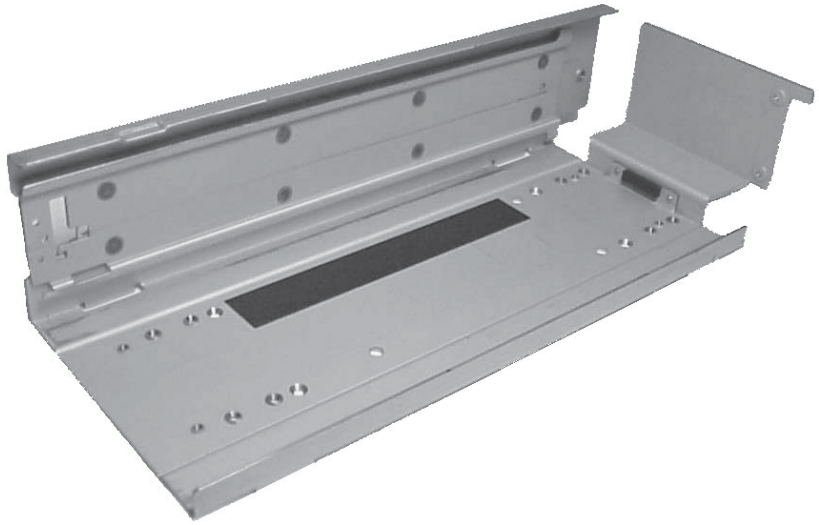

Typical Mounting Hole Locations

Operation

Loading the Paper

1. Fan the pre-cut paper before placing it in the hopper.
2. Lift the spring-loaded pressure plate.
3. Place the paper stack in the hopper with the printed side down.
4. Release the pressure plate.

NOTE: The hopper will hold 200 sheets of pre-cut paper unless the hopper extension has been added.

5. Replace the printer in the host machine.



Calibration Procedure

1. Make sure the power is turned off or disconnected from the printer.
2. Put all Dip switches in the ON position (see Fig. 1).
3. Open the printer head by pulling the printer halfway out of the frame and pulling up on the metal bar.
4. Place the white calibration paper (Part No. 501-000045) over the barcode and double-note sensors (see Fig. 2).
5. Close the printer head.
6. Apply power to the printer (30 second warm-up delay).
7. The LED flashes, 100 ms ON, 1 sec. OFF (see Fig. 3).
8. Open the printer head and remove the white calibration paper.

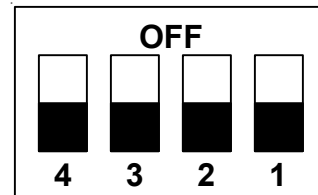

Figure 1.

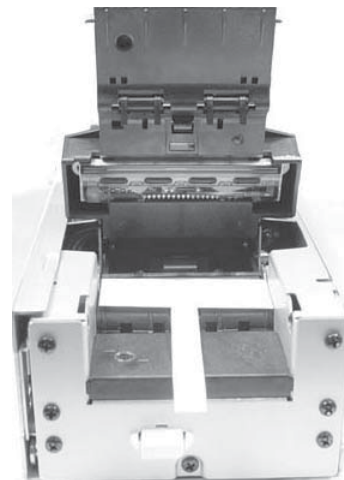

Figure 2.

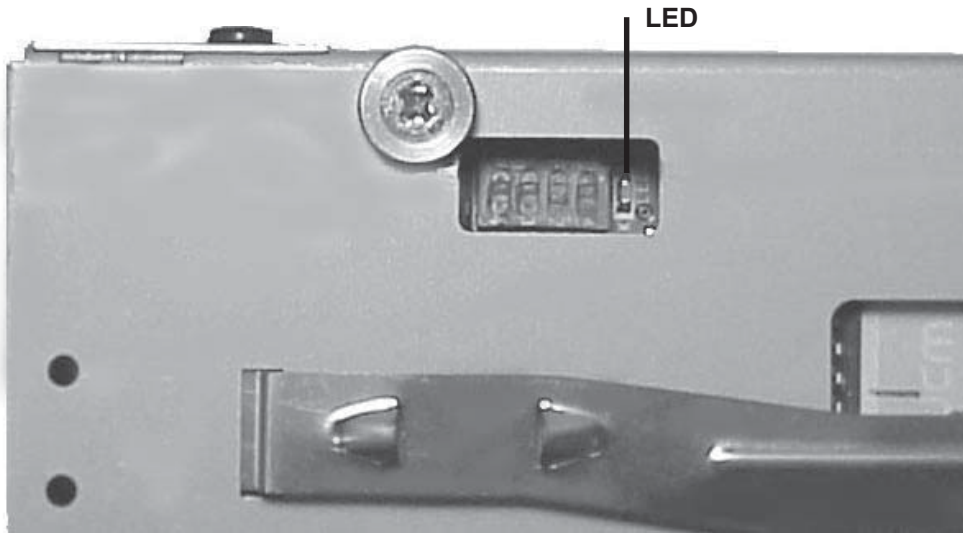

Figure 3.

9. Place the black calibration paper (Part No. 501-000044) in the same position.

10. Close the printer head.

11. Move Dip switch No. 4 to OFF (see Fig. 4)

12. The LED flashes 100 ms ON, 1 sec. OFF (see Fig. 3).

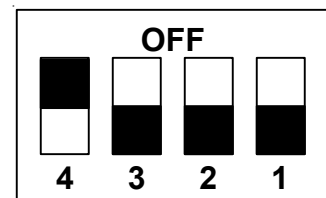

Figure 4

13. Open printer head and remove the black calibration paper.

14. Place the white calibration paper over the barcode and double-note sensors again.

15. Close the printer head.

16. Move Dip switch No. 1 to OFF (see Fig. 5).

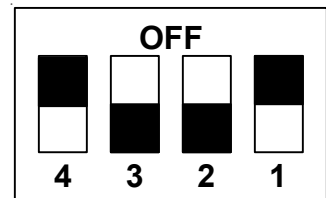

Figure 5

17. Wait until the LED comes on steady, approximately 15 seconds (A blinking LED indicates an error).

18. Open the printer head and remove the white calibration paper, then close the head.

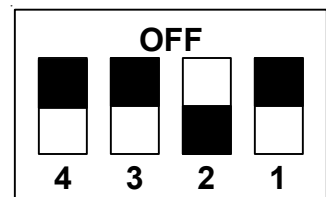

Figure 6

19. Move Dip switch No. 3 to OFF (see Fig. 6).

20. The LED flashes, 200 ms ON, 200 ms OFF.

21. Turn off the power to the printer.

22. Move all Dip switches to OFF.

Troubleshooting

When the printer receives a message from the host, it moves a single piece of paper from the hopper into the printer and prints the barcode information. The piece of paper is moved into another section where it is read to confirm accuracy. If there is an error condition, it moves the paper to the reject area, informs the host there was a problem, and waits further instructions.

If the printer detects more than a single piece of paper, it moves the paper to the reject area and attempts to re-print the ticket.

When the printer prints a single piece of paper and reads accurate barcode information, it releases the paper.

Out of paper sensor

Paper low sensor

There are two sensors in the hopper section. One sensor informs the host that the supply of paper is low, and the other sensor informs the host when the hopper is empty. There are other sensors along the path the paper takes that detect double papers and positioning.

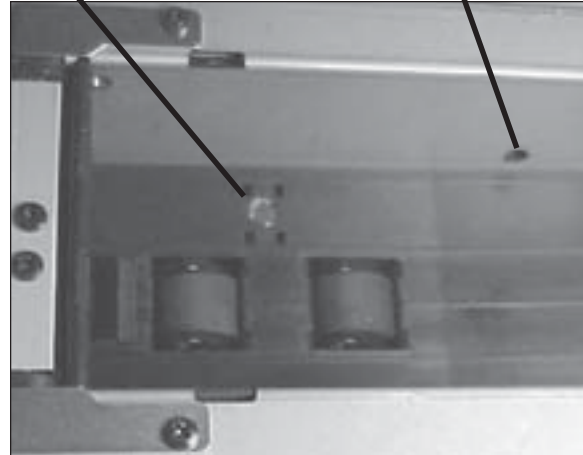

If there is a paper jam, the printer sends a message to the host and the host signals a paper jam. The only time a service technician becomes involved with the printer is when there is a paper jam, where there is a software update, and when the printer needs more paper (see “Loading Paper”).

Whenever the printer requires service, it is recommended that the reject area be cleared. To do this disconnect the ribbon cable from the computer, remove the printer from the frame, turn it over and remove the tickets.

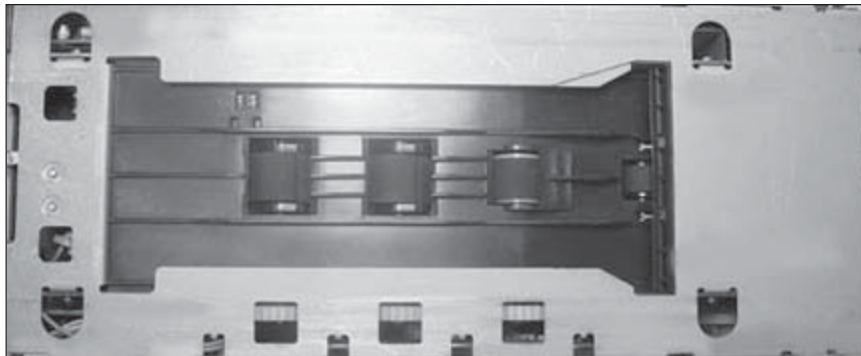

Reject area

Troubleshooting (Cont.)

It may become necessary to increase the printer contrast if the host receives a contrast error message. Use a small flat-head screwdriver to adjust the contrast control wheel (lower numbers increase contrast). Make minor adjustments, then test the printer to verify the results.



To replace the EPROM, it is necessary to remove the four (4) screws securing the side of the printer. Do not remove the screw securing the spring-loaded bar.

Slide the side panel toward the rear of the printer to release it.

When replacing the side panel, make sure all the tabs are inside the body slots before sliding the panel toward the front of the printer. Secure it with the four (4) screws.

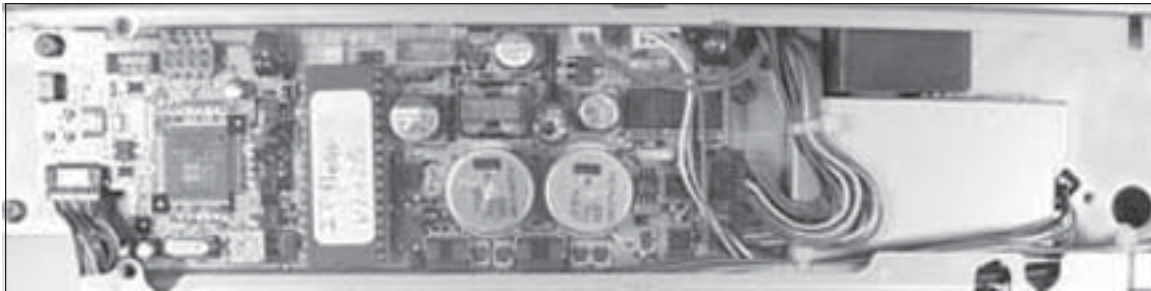

Troubleshooting (Cont.)

Problem	Possible Cause	Possible Solution
No power	1. Ribbon cable not seated properly 2. Printer is not all the way in the frame	Check ribbon connector at the rear of the printer Make sure the printer is all the way in the frame
Printer reject	Double paper sensed a. Sheets automatically go to reject area b. Printer will try to print a single sheet for 20 seconds c. Printer will send failure message to host	Remove all paper from the paper hopper and fan it Load additional sheets in paper hopper Run test to make sure paper pick-up isn't worn.
Printer reject	Bar code error a. Mismatched bar code data b. Incorrect narrow bar width c. Incorrect wide bar width d. Black/white contrast too low e. Too many bars f. First bar code character invalid	Clean the printer, test the software Clean the printer, test the software Clean the printer, test the software Adjust with contrast screw Clean the printer, test the software Clean the printer, test the software
Paper jam in hopper	Mis-aligned paper	Remove all paper from the paper hopper and fan it. Remove jammed piece. Carefully replace paper in hopper
Paper jam in printer	Mis-aligned paper	Open printer head. Remove jammed piece. Test for proper alignment
Printer will not accept Print message from host	Printer head overheated	Once the print head has cooled down, this problem will not occur.

Cleaning

To clean the TSP-01 remove all paper from the hopper and use compressed air to blow out any residue. Concentrate on the rollers and the sensors.

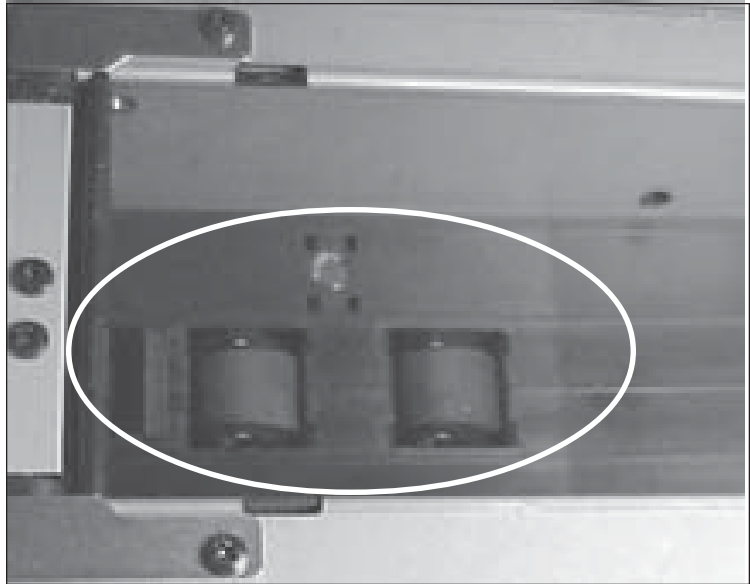

Open the head and use compressed air to remove any debris from the area. Then use a lint-free cloth and a 25% alcohol solution to gently clean the head area indicated in the photograph.

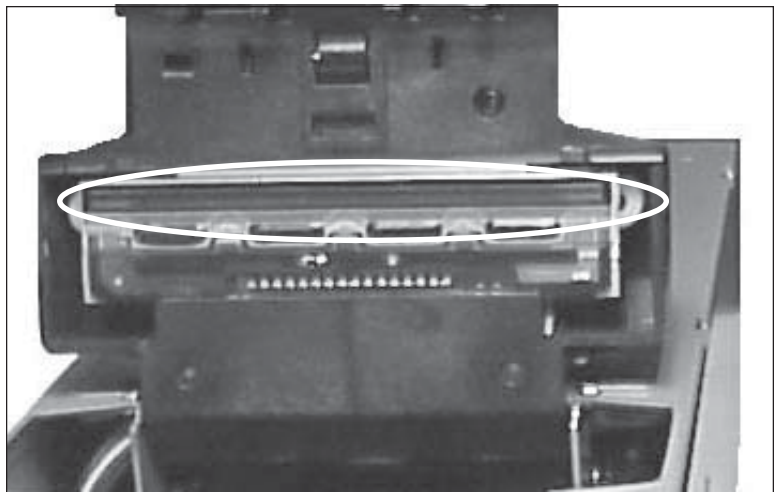

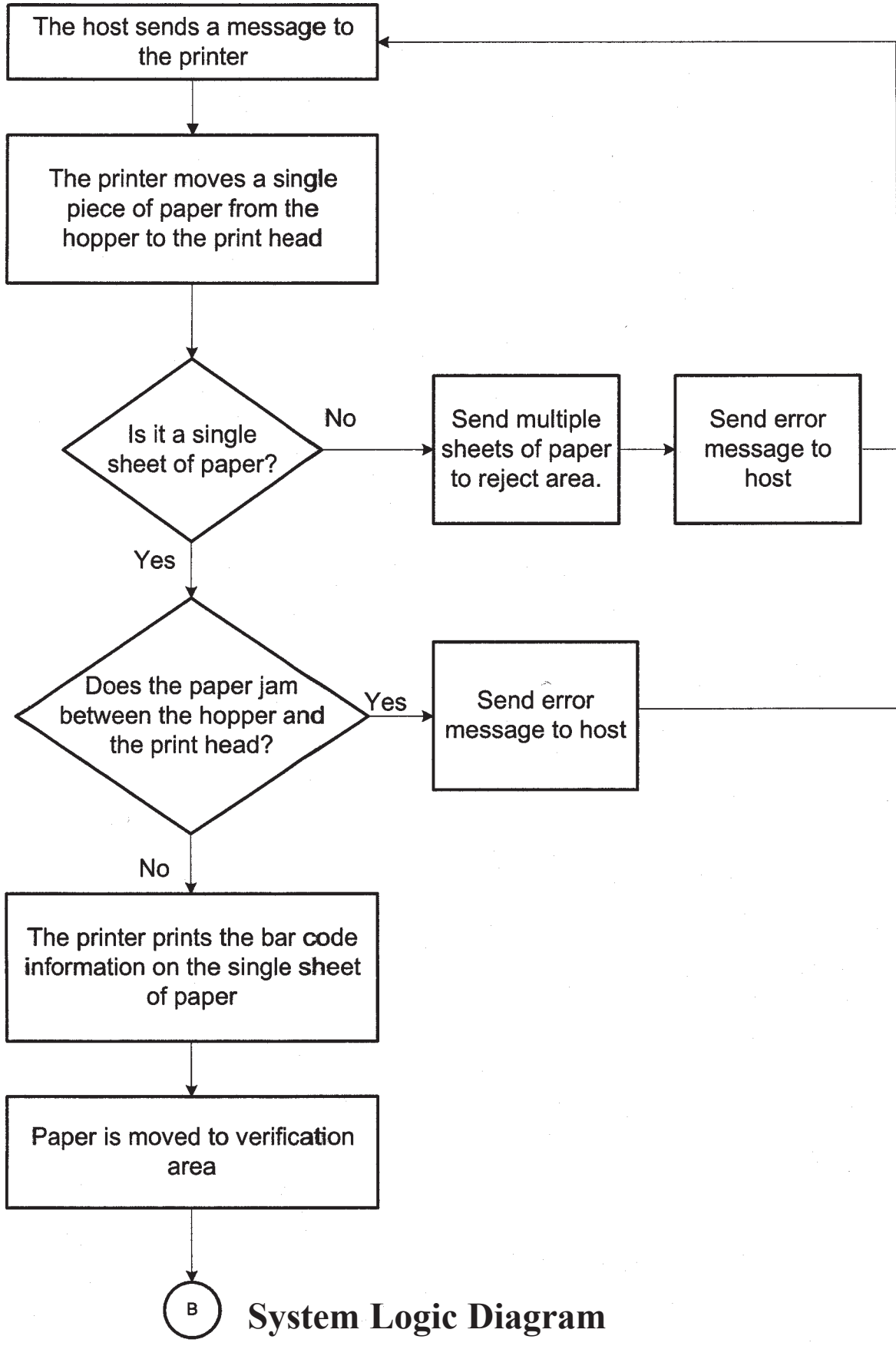

System Logic Diagram

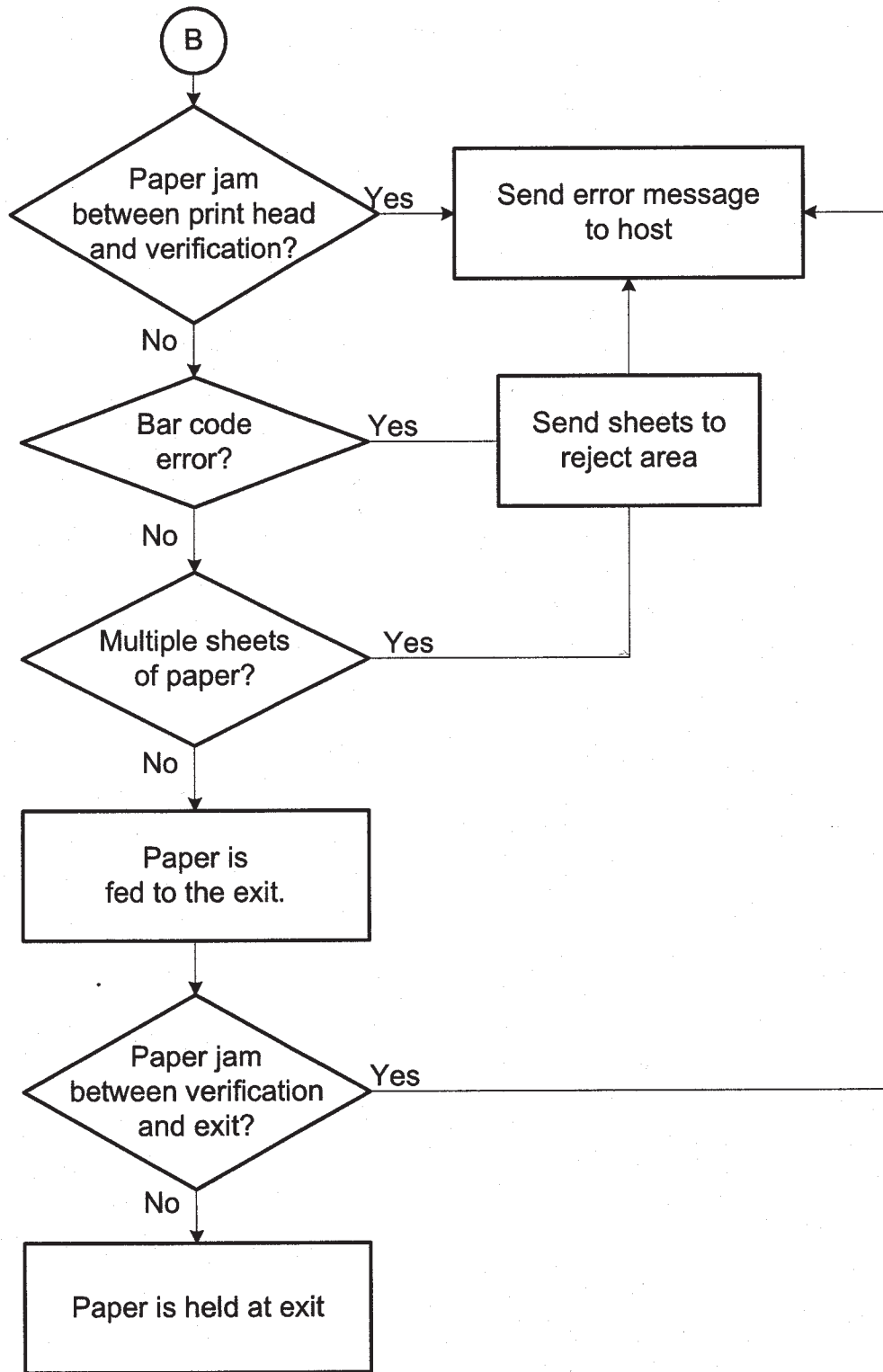

System Logic Diagram (Cont.)

Illustrated Parts Breakdown

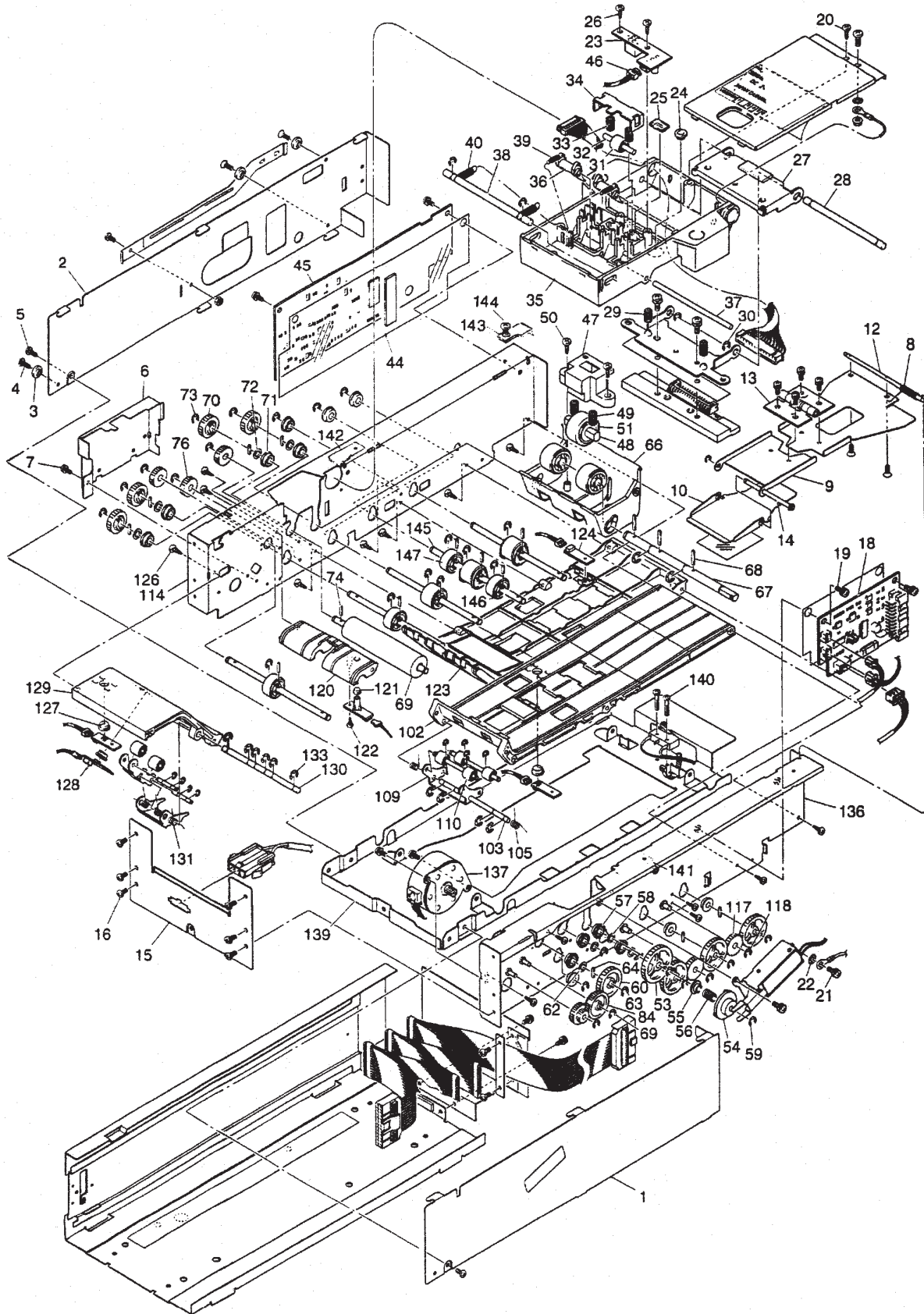

PARTS LIST

No.	EDP	Part No.	Description	Qty.
1	071874	0667PT0110B	Side Cover (R)	1
2	071875	0667PT0111B	Side Cover (L)	1
3	071846	0667BU0101A	Slide Guide Bush	3
4				
5	025205		M3X5 Bind (Fe CR)	9
6	071872	0667PT0108B	Harness Guide (L)	1
7				
8	074078	0667KS0106	Paper pusher spring	1
9	073770	0667PT0125A	Paper pusher (B2)	1
10	072277	0667PT0120C	Paper pusher (A)	1
11	073769	0667PT0124A	Paper pusher (B1)	1
12	073773	0667SH0117A	Paper pusher F	1
13	073775	TH-61SUS-1	Spring Hinge	1
14	073774	0667SH0118B	Paper pusher shaft	1
15	071873	0667PT0109A	Front plate	1
16				
17	071901	0667PE0104B	Sub Board Seat	1
18	071882	667-3140-06-02C-01	I/F Assy	1
19				
20				
21				
22				
23	071849	667-3140-06-06A-01	Barcode sensor PCB	1
24	040342	RE-7AJ04A	Sensor bush (f 5)	2
25	052523	0943RE0129A	Bush (RE)	1
26				
27	071867	0667PT0102B	Head bracket	1
28	071842	0667SH0113	Head shaft	1
29	071885	0667CS0102	Head spring	2
30				
31	071909	0667RE0101	Pinch roller	7

No.	EDP	Part No.	Description	Qty.
32				
33	071884	0667CS0101	Tension roller spring	2
34	071913	0667RE0105	Spring stopper	1
35	071921	0667RE0113B	Upper guide	1
36	071920	0667RE0112	Reject lever	2
37				
38	071836	0667SH0107	Lock shaft	2
39	071881	0667TS0102	Lever spring	2
40	071880	0667TS0101	Lock spring	1
41				
42				
43	071761	3140-05-04A	Sensor (B) harness	1
44	071900	0667PE0103B	CPU Board seat	1
45	071768	667-3140-06-0	1B-01CPU Assy	1
46	071760	3140-05-03D	Sensor harness	1
47	071914	0667RE0106	Gate roller cover	1
48	071843	0667SH0114	Gate roller shaft	1
49	071886	0667CS0103	Gate roller spring	2
51	071856	0667RU0104	Gate roller	1
52	017669	NHF06	One way clutch	1
53	071907	0667GE0105A	Feed gear	4
54	071922	0667RE0114	Clutch	1
55	071847	0667CO0101	Clutch collar	1
56	071887	0667CS0104A	Clutch spring	1
57	033218	DDLDF-850ZZ	Bearing	8
58	072272	5X7XT0.4	Polyslider	6
60	071906	0667GE0104A	Feed gear (B)	4
66	071915	0667RE0107A	Gate roller guide	1
67	071839	0667SH0110	Feed shaft	1
69	071853	0667RU0101	Platen	1
76	071908	0667GE0107A	Idol gear (C)	5
78	034397	B-F5-53	Metal bearing	6
82	071904	0667GE0103A	Feed gear (A)	1

No.	EDP	Part No.	Description	Qty.
83	071903	0667GE0102	Idol gear (A)	1
84	071905	0667GE0106	Idol gear (B)	1
102	071918	0667RE0110A	Lower guide (C)	1
103	071863	0667SH0104	Pinch roller lever F	1
104	071890	0667KS0103	Pinch roller SP(B)R	1
105	071891	0667KS0104	Pinch roller SP(B)L	1
106	071848	667-3140-06-04A	Refractive sensor	4
107	052524	0943RE0130A	Bush (LED)	3
109	071869	0667PT0104	Pinch roller lever	1
111	071864	0667SH0105	Pinch roller shaft (C)	1
112	071865	0667SH0106	Pinch roller shaft (D)	1
114	071895	0667AS0103B	Side frame (L) assy	1
120	071916	0667RE0108A	Lower guide (A)	1
123	071917	0667RE0109A	Lower guide (B)	1
129	071919	0667RE0111	Lower guide (E)	1
130	071859	0667SH0101	Pinch roller BKT F	1
131	071888	0667KS0101	Pinch roller SP(A)R	1
132	071889	0667KS0102	Pinch roller SP(A)L	1
137	073918	PM35L048ZWE5G	Stepping motor	1
139	071876	0667PT0112	Unit base	1
140	046767		M3X8 Pan screw	2
141	077339	0667PT0135	Paper pusher plate	1
142	077341	0667PT0136	Upper guide plate (L)	1
143	077340	0667PT0134	Upper guide plate (R)	1
144			M3X5 Bind (Black) F	3
145	076149	0667SH0119	Feed shaft (G)	1
146	071912	0667RE0105A	Feed roller (C) pulley	6
147	071857	0667RU0105A	Feed roller (C)	6
148	075615	667-3140-05-50-01	Buzzer assy	1
149	078241	0667PR0902	PCB SIM plate	(4)



925 Pilot Road, Las Vegas, Nevada 89119

Office: (800) 683-7248, Tech. Support: (702) 651-3444, FAX: (702) 651-0214

E-mail: techsupport@jcm-american.com

<http://www.jcm-american.com>