

# MC2600 Note Acceptor Application Data 120VAC

This document is the private unpublished property of Money Controls Inc. and may not be reproduced in part or in total by any means, electronic or otherwise, without the written permission of Money Controls Inc. Money Controls Inc. does not accept liability for any errors or omissions contained within this document. Money Controls Inc. shall not incur any penalties arising out of the adherence to, interpretation of, or reliance on this standard. Money Controls Inc. reserves the right to amend, improve or change the product referred to within this document or the document itself at any time.

**Application & Features:** The MC2600 was designed for amusement, music and special OEM applications.

**Input Voltage:** 120VAC

**Interface:** Pulsed, Vend Serial and RS232

**Acceptance:** \$1, \$5, \$10, \$20 with 4-way acceptance

**Mounting:** Up stacking or Down stacking

**Part Number:** The MC2600 part numbers are structured to define the major components as shown in Fig 1.

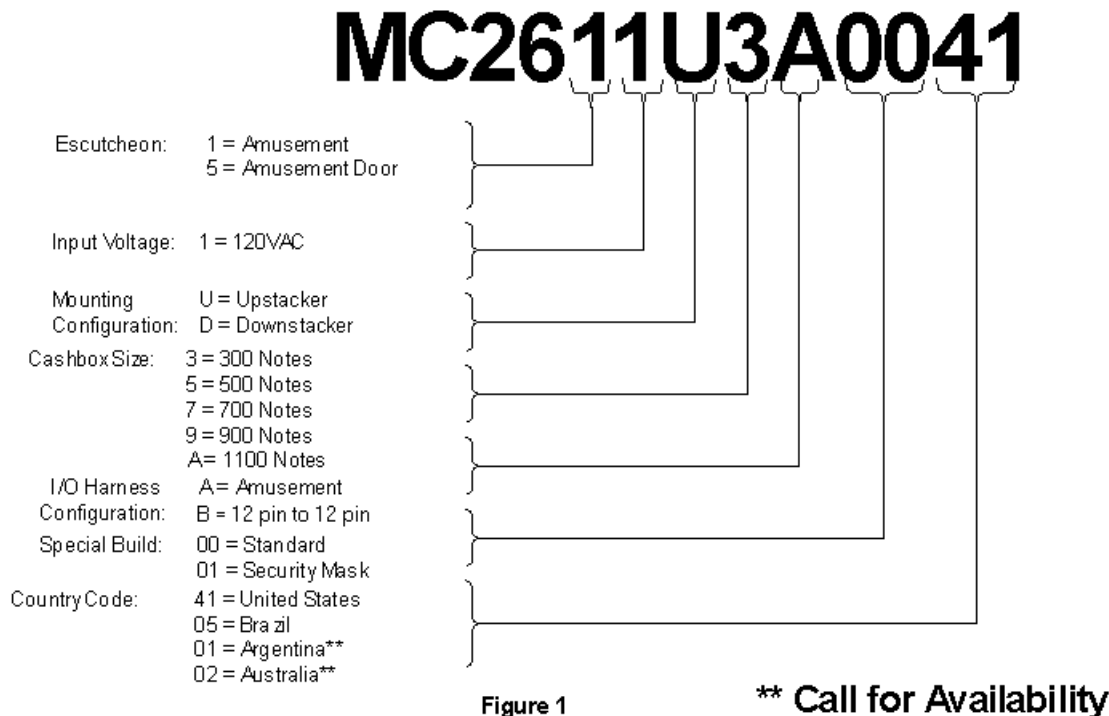

**Installation:**      **NOTE: Pin 2 Ground and the Metal mounting plate must be connected to earth ground.**

1. Remove power from host machine.
2. Set Note Acceptor dip switches, if required. (see Figure 2)
3. Install the MC2600 into the host machine via the mounting studs and hardware.
4. Install / Connect the proper interface harness to the host machine.
5. Apply power to the machine, verify that the Green Flashing Arrow on the front of the note acceptor are ON and blinking. This condition indicates that the MC2600 is ready to accept notes.
  - If the Lights are off, check connections and make sure power is applied.
  - Also check the rear diagnostic LED, the status codes are listed on the cashbox.
6. Check Operation, once the Green Arrows are flashing insert a \$1, \$5, \$10 or \$20 to verify that note will accept and credit properly in the host machine.

**Maintenance:****RECOMMENDED CLEANING MATERIALS**

Isopropyl Alcohol is readily available and safe for the acceptor, personnel and the environment when used as instructed in this manual. If used improperly, it can harden and destroy the belts and other similar components.

A mild solution of detergent can be used for cleaning the belts, bill path and sensor lenses, as well as for general cleaning of the acceptor. Beverages or other water-soluble liquids which have been spilled on or into the acceptor can usually be removed with warm soapy water. External surfaces can be cleaned with a damp cloth.

**BELT CLEANING CARDS**

Use a cleaning card for field cleaning the MC2600 belts. A cleaning card is a strip of textured absorbent paper, slightly larger than a US bill. The paper is saturated with isopropyl alcohol. Cleaning cards are available from several industrial sources. If you need help locating cleaning cards, contact Money Controls or Coin Co.

**Note: The MC2600 must be enabled, ready to take a bill in order to use a cleaning card.**

**CLEANING CARD FREQUENCY**

Ideally, a cleaning card should be run through the acceptor approximately once a month. Adjust the cleaning frequency as local conditions dictate. The cleaning card can be used without opening the bill acceptor or host machine. However, a visual inspection of the acceptor's bill path is recommended as part of on site service and cleaning.

**Warning: Remove power from the bill acceptor before opening the bill path.**

## **CLEANING THE OPTICAL SENSOR LENSES AND GRAY SCALES**

Remove the cash box and bottom sensor housing from the acceptor. To clean the optical sensor lenses and gray scales use a “Lint Free” cloth with a mild detergent or isopropyl alcohol. Repeat the cleaning process as needed until all the sensor surfaces are free of contaminants. Remember to clean the sensor lenses on both sensor plates.

### **Dip Switch Configuration:**

#### **DEFAULT SETTING (ON)**

	<b><u>ON</u></b>	<b><u>OFF</u></b>
Switch 1	\$1 enabled	\$1 disabled
Switch 2	\$5 enabled	\$5 disabled
Switch 3	\$10 enabled	\$10 disabled
Switch 4	\$20 enabled	\$20 disabled
Switch 5	4 pulse per \$	1 pulse per \$
Switch 6	Always Enabled	Host Enabled
Switch 7	Short Pulse (50ms ON 50ms OFF)	Long Pulse (60ms ON 300ms OFF)
Switch 8	Pulsed Protocol	Vend Serial Protocol

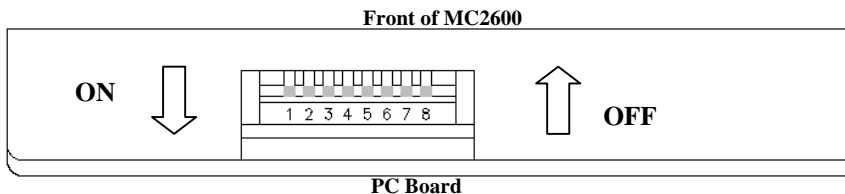

**Figure 2 Dip Switch Locations and Position**

### **Interface Connectors:**

#### 18 – pin Interface Connector Pulsed, Vend Serial and RS232

Mating Connector Housing With Contacts:	AMP# 102398-7	Money Controls Inc.# 35x542-18
Latching Front Cover	AMP# 102681-4	Money Controls Inc.# 35x544-18
Back Cover	AMP# 102536-7	Money Controls Inc.# 35x543-18

#### 8 – pin Download and Diagnostics

Mating Polarized Connector	AMP# 87631-3 or 2-87977-9	Money Controls Inc.# 35x816-8
Receptacles Contacts	AMP# 85969-9 or 86016-3	Money Controls Inc.# 35x245

#### 6 – pin Input Power / Pulsed Vend Relay Output

Mating Polarized Connector	AMP# 87631-1 or 2-87977-8	Money Controls Inc.# 35x816-6
Receptacles Contacts	AMP# 85969-9 or 86016-3	Money Controls Inc.# 35x245

#### 9 – pin Input Power / Pulsed Vend Relay Output Amusement Harness (Amusement Harness Part# 02x7205)

Mating Connector Housing:	AMP# 172161-1	Money Controls Inc.# 35x412-9
Mating Male Pin:	AMP# 170364-1	Money Controls Inc.# 35x408

### Warranty

New Money Controls MC2600 Note Acceptors are warranted to be free from defects in material or workmanship under normal use and service for a period of 24 months from date of manufacture. The first four digits of the serial number indicate the date of manufacture:

Digits 1 & 2	(01-52)	Week 01 through Week 52
Digits 3 & 4	(00-99)	Last two digits of the year 00 (2000) through 99 (2099)

### Input Power Requirements

120VAC One supply voltage is required: 90 – 135 VAC @ 1.0A

### Rear Diagnostic LED

<b>Diagnostics</b>	
# of LED Flashes	LED Status
Normal Pulse Rate 1 pulse per second	Ready
Fast Pulse Rate 3 pulses per second	Check Stacker / Cashbox
Not Lit	Check Power
Steady ON	Replace Acceptor
2 Flashes	Bill Inhibited
3 Flashes	Disabled by Host
4 Flashes	Clear Bill Path
5 Flashes	Clean Bill Path

### Technical Support

Money Controls  
34099 Melinz Parkway  
Eastlake, OH 44095

Phone: 800.321.0765  
Phone: 440.946.3000  
Fax: 440.946.9829  
Email: [technical.usa@moneycontrols.com](mailto:technical.usa@moneycontrols.com)  
Web Site: [www.moneycontrols.com](http://www.moneycontrols.com)

Coin Acceptors

Phone: 800.325.2646  
email: [techsupport@coinco.com](mailto:techsupport@coinco.com)  
Web Site: [www.coinco.com](http://www.coinco.com)

### Additional Support Data:

RS232 Protocol:	44x449
Exploded View Parts Diagram & Parts List:	47x270

Money Controls Inc. Ordering Number (Call for Availability)

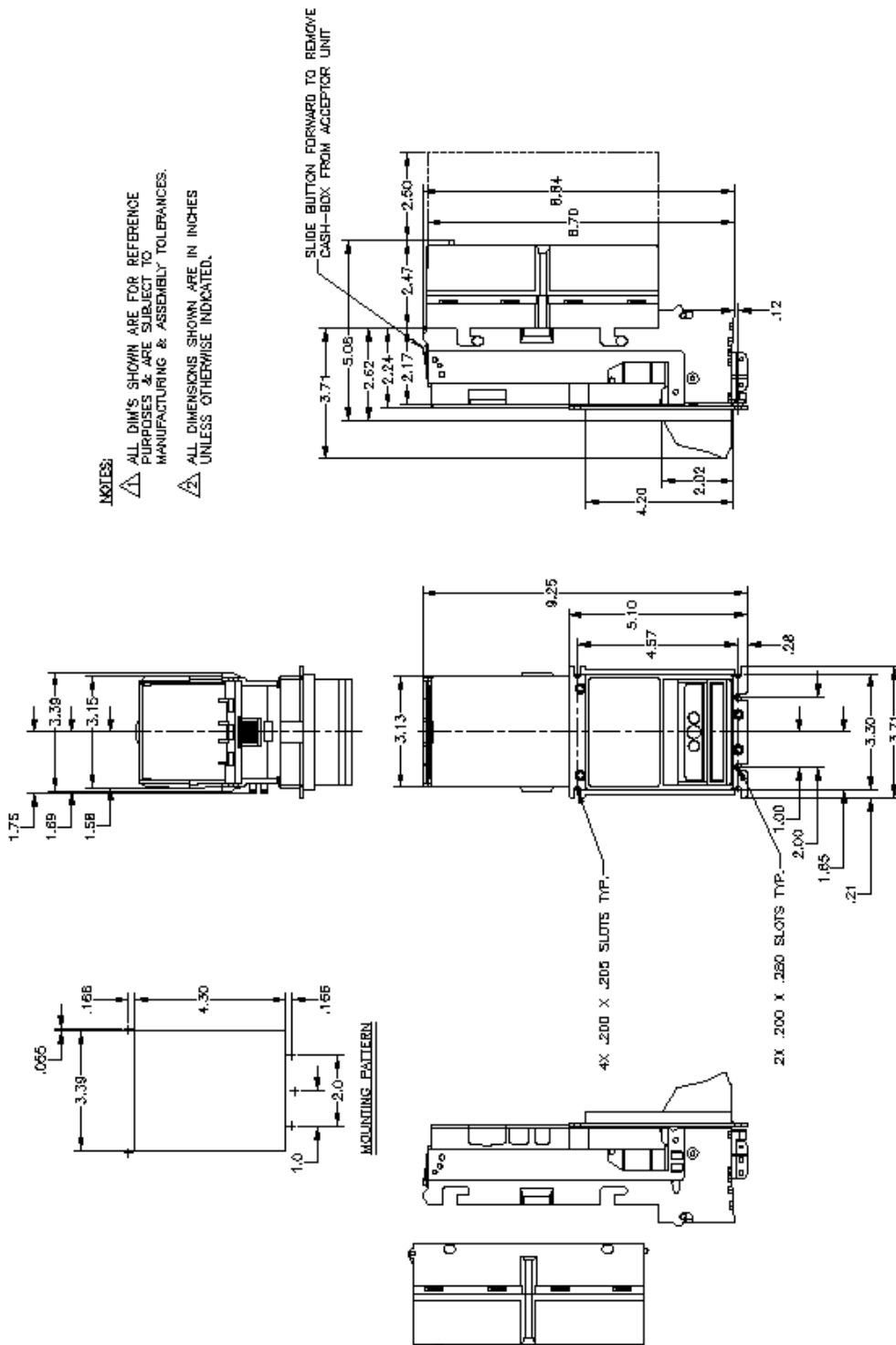
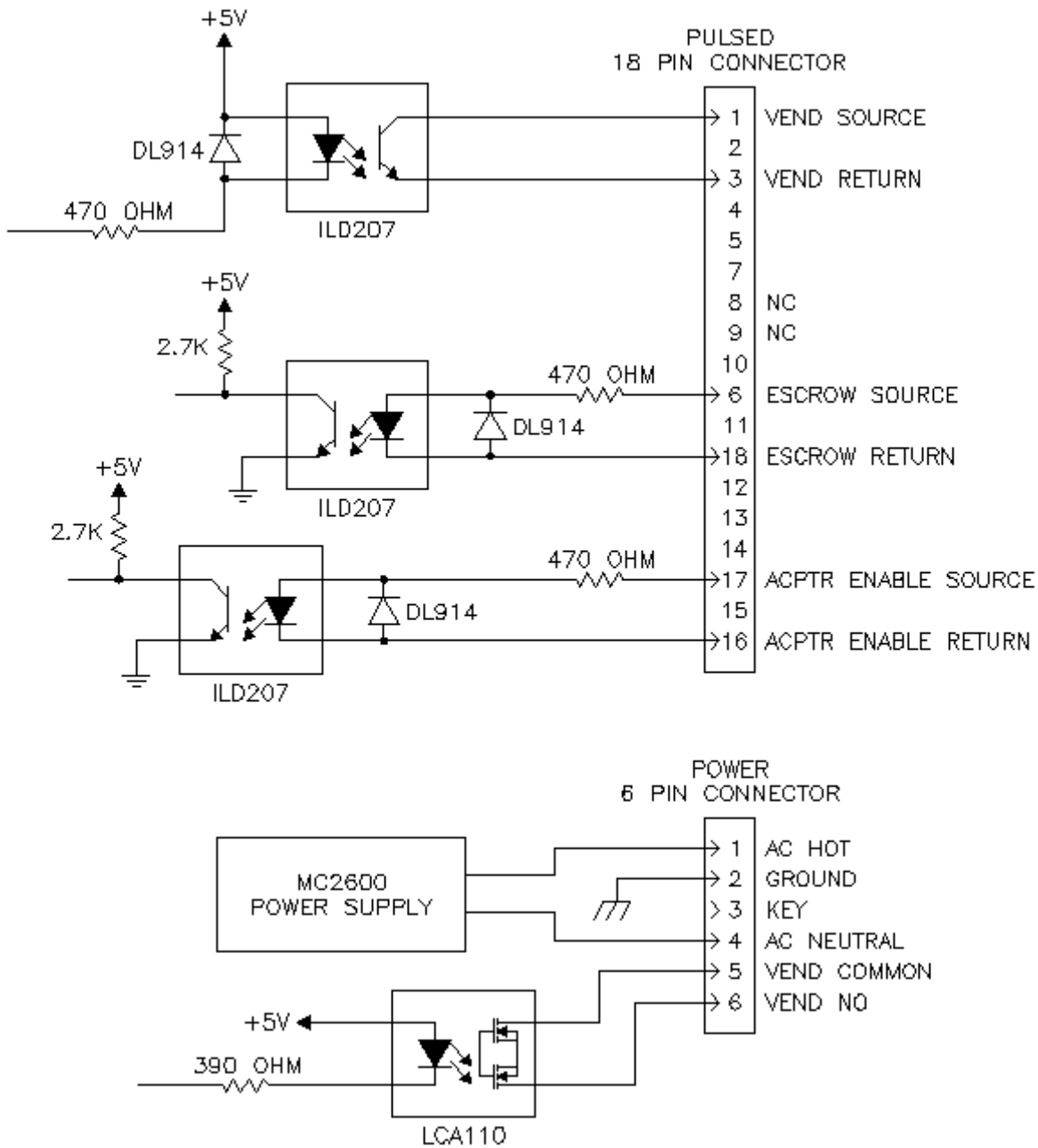

Figure 3 MC2600 Dimensional Drawing (Up Stacking Position)

MC2600 Depth with Cashbox	
300 = 4.66	900 = 7.10
500 = 5.00	1100 = 8.15
700 = 6.05	



**NOTE: Pin 2 Ground and the Metal mounting plate must be connected to earth ground.**

Figure 4 Pulsed Interface Connections

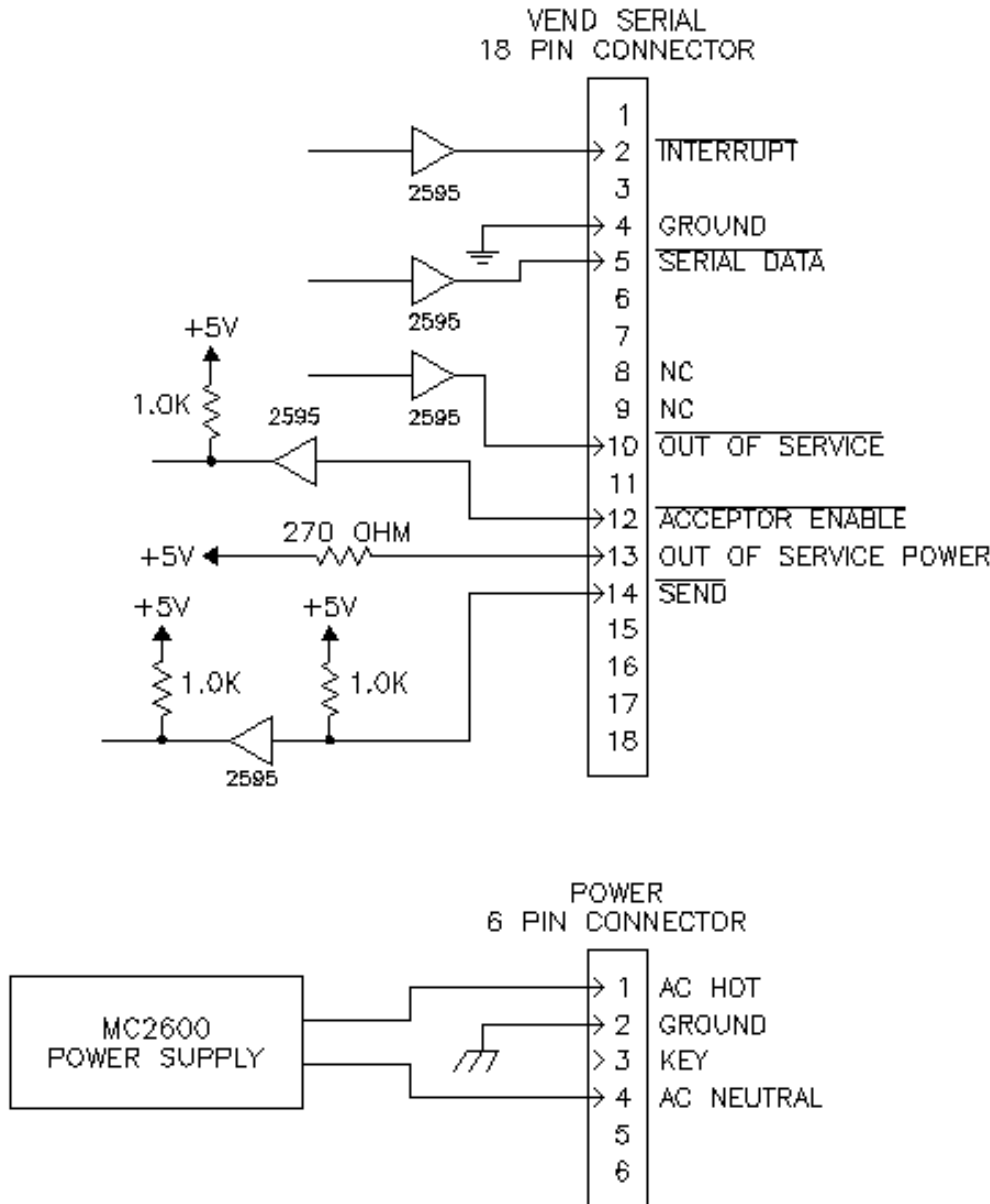

**NOTE: Pin 2 Ground and the Metal mounting plate must be connected to earth ground.**

Figure 5 Vend Serial Interface Connections

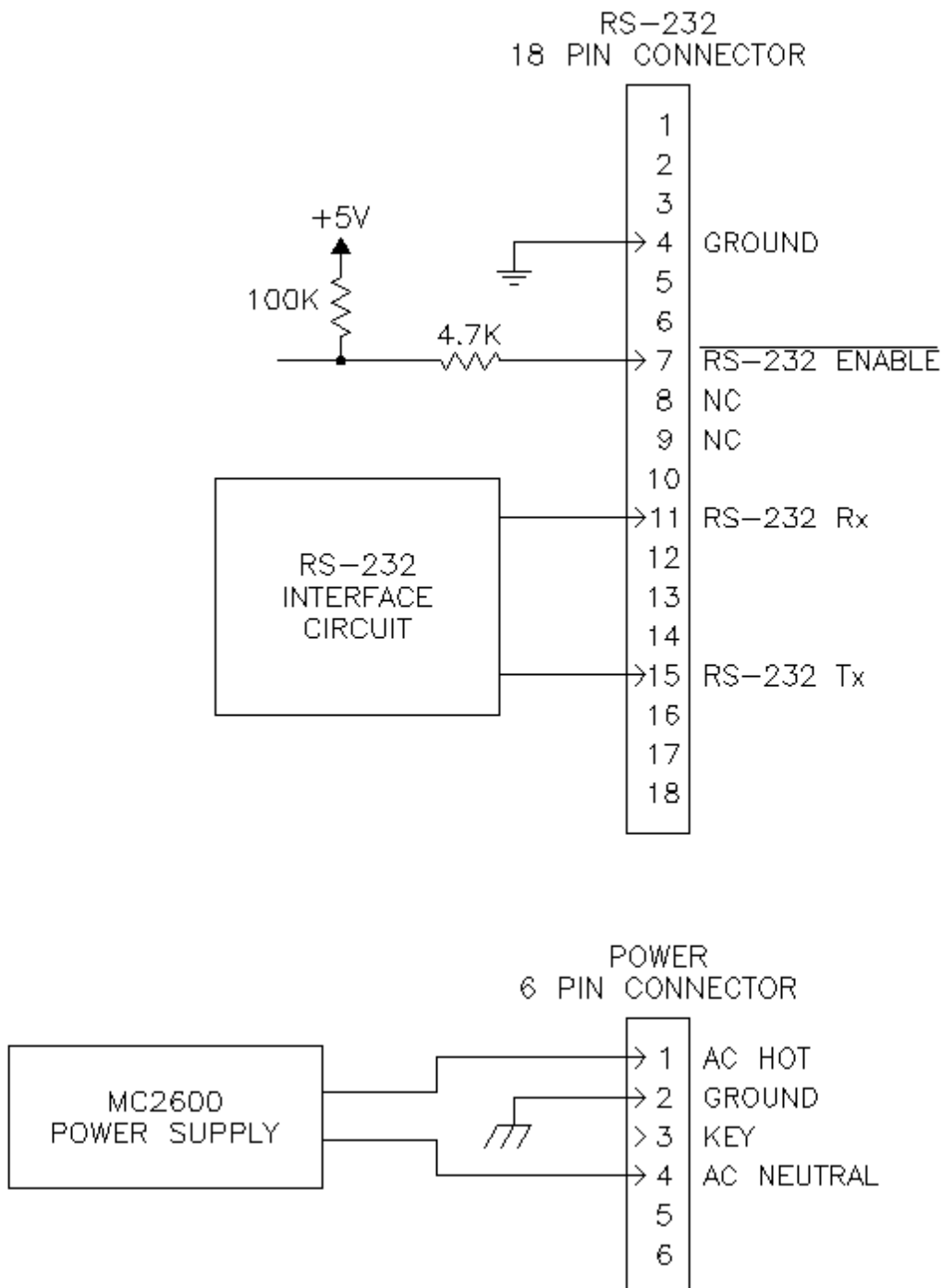

**NOTE: Pin 2 Ground and the Metal mounting plate must be connected to earth ground.**

Figure 6 RS232 Interface Connections



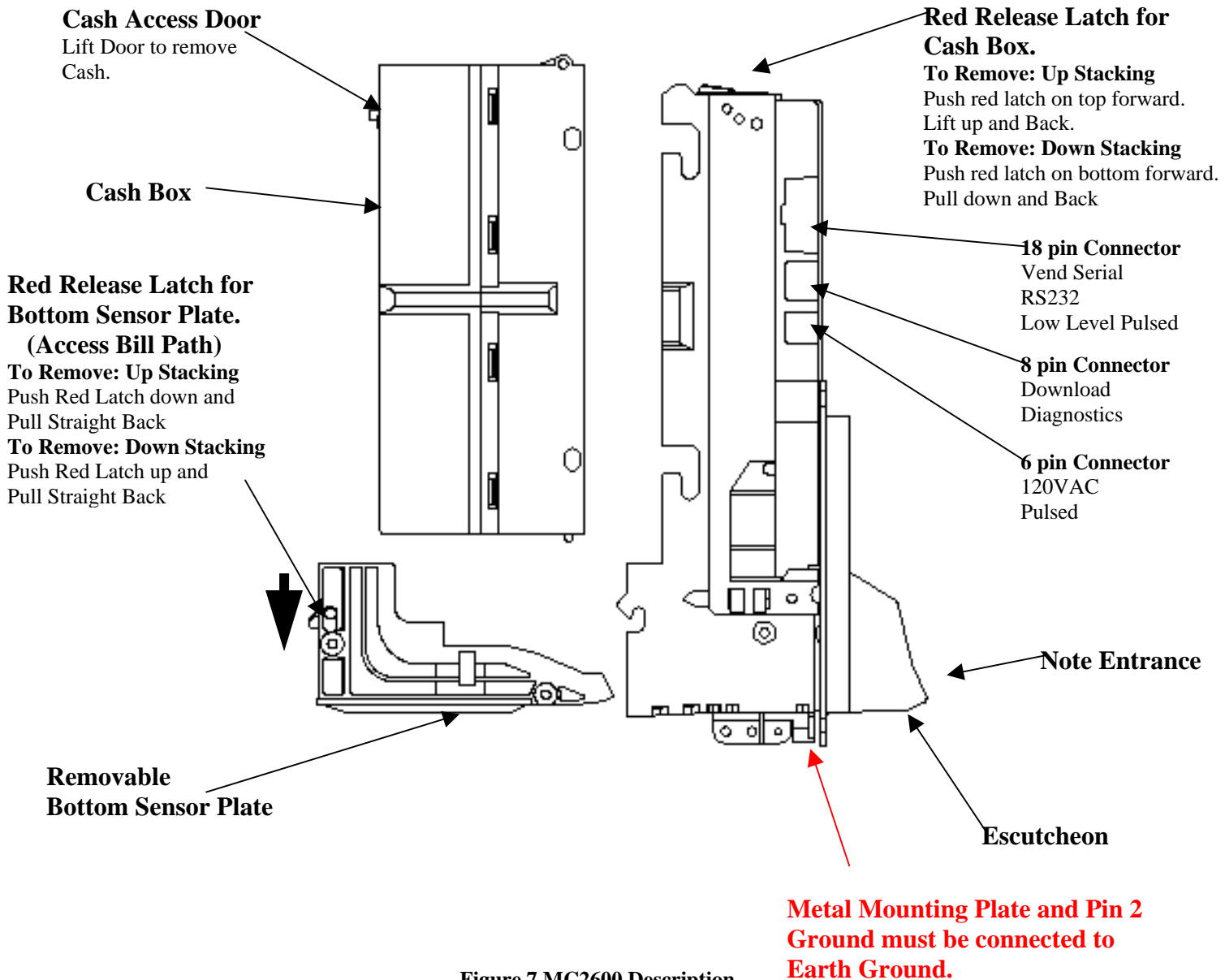

Figure 7 MC2600 Description  
(MC2600 in Up Stacking Position)