

# SR5

# Technical

# Manual



This document is the copyright of Money Controls Ltd and may not be reproduced in part or in total by any means, electronic or otherwise, without the written permission of Money Controls Ltd. Money Controls Ltd does not accept liability for any errors or omissions contained within this document. Money Controls Ltd shall not incur any penalties arising out of the adherence to, interpretation of, or reliance on, this standard. Money Controls Ltd will provide full support for this product when used as described within this document. Use in applications not covered or outside the scope of this document may not be supported. Money Controls Ltd. reserves the right to amend, improve or change the product referred to within this document or the document itself at any time.

## Contents:

<b>1. Diary of changes</b> .....	<b>4</b>
<b>2. Introduction</b> .....	<b>4</b>
<b>3. Operation</b> .....	<b>6</b>
<b>4. UK AWP Industry Standard</b> .....	<b>7</b>
<b>5. Electrical Connections</b> .....	<b>8</b>
<b>6. Stud Positions</b> .....	<b>9</b>
<b>7. Electrical Interface Requirements</b> .....	<b>10</b>
7.1 Accept Common (COM A) .....	10
7.2 Standard Inputs .....	11
<b>8. Alarms</b> .....	<b>12</b>
8.1 Power-up Diagnostics .....	12
<b>9. Dual Coin Entry Rundown Interface (DCE)</b> .....	<b>13</b>
<b>10. Parallel Interface</b> .....	<b>14</b>
10.1 Ident Pin.....	14
10.2 Coin Accept Outputs .....	15
10.3 Select Input.....	17
10.4 Inhibit Lines.....	18
10.5 Bank Select Parallel Inputs (Modes 1, 4, 7 and 8).....	18
<b>11. Sorting Coins</b> .....	<b>19</b>
11.1 4-way Sorter .....	19
11.2 8-way Sorter (Active Manifold).....	19
<b>12. Sorter Overrides</b> .....	<b>20</b>
12.1 4-Way Override.....	20
12.2 8-Way Override.....	21
<b>13. Sorting Modes</b> .....	<b>22</b>
13.1 Routing Plug (4 way sorting only) .....	22
13.2 Using the routing plug .....	22
13.3 EEPROM mode (4-way / 8-way sorting) .....	22
<b>14. Active Manifold Interface</b> .....	<b>22</b>
<b>15. Diagnostics</b> .....	<b>24</b>
15.1 Inhibit/Accept line and Inductive Noise Test .....	24
15.2 Solenoid and Inductive Sensor Flash Test.....	25
15.3 Opto Test .....	26
15.4 Exit Diagnostics .....	26
<b>16. Bank Select Switches</b> .....	<b>27</b>
<b>17. Rotary Switch Options</b> .....	<b>28</b>
17.1 Token Group Selection .....	28
17.2 Teach and Run™ Token “F” .....	29
17.3 Teach and Run™ Coins .....	29
17.4 Alarm and Rundown settings “D” .....	30
17.5 Routing Plug / EEPROM mode “E” .....	31
<b>18. Label Details</b> .....	<b>32</b>
<b>19. ccTalk Protocol</b> .....	<b>33</b>
19.1 Serial Interface.....	33
<b>20. ccTalk Serial Messages</b> .....	<b>34</b>
20.1 ccTalk Error Codes .....	35
20.2 ccTalk Fault Codes .....	35
20.3 ccTalk Status Codes .....	35
<b>21. ccTalk Interface Circuits</b> .....	<b>36</b>
21.1 Circuit 1 – ccTalk Standard Interface .....	36
21.2 Circuit 2 – ccTalk Low Cost Interface.....	37
21.3 Circuit 3 – ccTalk Direct Interface .....	38
21.4 Circuit 4 – ccTalk PC Interface .....	39
<b>22. Servicing</b> .....	<b>40</b>
22.1 Front Entry - Removal and Refitting.....	40
22.2 Top Entry - Removal and Refitting.....	40
22.3 Cleaning.....	41
22.4 Accept Gate .....	41
22.5 Sorter.....	41
22.6 Rear Cover .....	41
<b>23. Fault Finding</b> .....	<b>42</b>

<b>24. Mechanical Specification .....</b>	<b>43</b>
24.1 Position .....	43
24.2 Coin/Token Sizes .....	43
24.3 Specified EMC Performance .....	44
24.31 Emissions .....	44
24.32 Immunity .....	44
24.33 Shock / Vibration Immunity .....	44
24.4 Environmental specification .....	44
24.5 Material Flammability Rating .....	44
24.6 Top Entry dimensions .....	45
24.7 Bezel Dimensions .....	46
24.8 Front Entry Dimensions .....	47
24.9 Manifold Coin Exit Paths .....	48

## Tables:

Table 1: SR5 Rear Cover Details .....	8
Table 2: Power Supply .....	10
Table 3: Current Consumption .....	10
Table 4: COM A DC Input Characteristics .....	10
Table 5: Standard Input DC characteristics .....	11
Table 6: Parallel Interface .....	14
Table 7: Accept output DC characteristics .....	15
Table 8: 5 Coin Mode Accept Outputs (standard – Mode 1) .....	17
Table 9: 16 Coin Mode Accept Outputs (standard – Mode 1) .....	17
Table 10: <b>ccTalk</b> Serial Commands .....	34
Table 11: <b>ccTalk</b> Error Codes .....	35
Table 12: Fault Codes .....	35
Table 13: Status Codes .....	35
Table 14: Environmental Ranges .....	44

## Figures:

Figure 1: Standard Top Entry configuration using bezel and rundown .....	7
Figure 2: SR5 Connector Side .....	8
Figure 3: Input Hardware Configuration .....	11
Figure 4: DCE Connector Pin Outs .....	13
Figure 5: Accept Outputs .....	16
Figure 6: 4-way sorter paths .....	19
Figure 7: 8-way Active Manifold sorter paths .....	19
Figure 8: Sorter Overrides 4-way .....	20
Figure 9: Sorter Overrides 8-way .....	21
Figure 10: Routing Plug Connections .....	22
Figure 11: Active Manifold connector .....	23
Figure 12: Bank Select switches .....	27
Figure 13: Rotary switch .....	28
Figure 14: SR5 Label Details .....	32
Figure 15: <b>ccTalk</b> pin header .....	33
Figure 16: Circuit 1, <b>ccTalk</b> Standard Interface .....	36
Figure 17: Circuit 2, <b>ccTalk</b> Low Cost Interface .....	37
Figure 18: Circuit 3, <b>ccTalk</b> Direct Interface .....	38
Figure 19: Circuit 4, <b>ccTalk</b> PC Interface .....	39
Figure 20: Front Entry Removal Diagram .....	40
Figure 21: SR5 Accepted Coin Dimensions Graph .....	43
Figure 22: SR5 Top Entry with Sorter Dimensions .....	45
Figure 23: Oval Bezel Dimensions .....	46
Figure 24: Panel Fixing Dimensions .....	46
Figure 25: SR5 Front Entry Dimensions .....	47
Figure 26: SR5 Manifold Coin Exit Paths .....	48
Figure 27: Top Entry / Front Entry Exploded View .....	49

## 1. Diary of changes

Issue 1.0.....	January 2001
Issue 2.0.....	April 2001
➤ Amended Fig 1.	
➤ SR5 Label detail added.	
➤ Added a line to <b>Teach and Run™</b> procedure.	
➤ Removed power-up diagnostics – Credit sensor blocked/faulty.	
➤ Exit diagnostics modified.	
➤ Added coin diameter/thickness graph.	
➤ Addition of new Modes.	
Issue 3.0.....	October 2001
➤ <b>ccTalk</b> details added.	
➤ Last page disclaimer amended.	
➤ Fig 21 amended.	
➤ Accept flap removal updated.	
➤ Reference to C220B removed from Mode 3.	
➤ Mode 10 now C220B only.	
➤ Diagram of stud positions added.	
Issue 4.0.....	31 <sup>st</sup> March 2002
➤ Applied TMWP V3.0	
➤ TSP012 reference added	
➤ Changed the Com A Figure	
Issue 4.1.....	6 <sup>th</sup> Sept 2002
➤ Modification to disclaimer	
Issue 5.0.....	2 <sup>nd</sup> Dec 2002
➤ Front Entry / Direct Reject drawing added - <a href="#">Figure 26</a>	
➤ 24V added to <a href="#">19.1 Serial Interface</a> connector.	
➤ Added <a href="#">Figure 27</a> SR5 Manifold Coin Exit Paths.	
➤ Mode 11 added.	
➤ Added the Oval Bezel dimensions <a href="#">Figure 24</a>	
Issue 5.1.....	12 <sup>th</sup> Dec 2002
➤ Corrected <a href="#">Figure 27</a>	
Issue 5.2.....	20 <sup>th</sup> Jan 2003
➤ Applied TMWP V3.2	
➤ <a href="#">Figure 25</a> added.	
Issue 5.3.....	24 <sup>th</sup> Jul 2003
➤ Updated the voltages in <a href="#">Table 5</a> .	
➤ Updated Stud Positions to Include “D” – Section <a href="#">6</a> .	
➤ Updated Label Details to include New Label – Section <a href="#">18</a> .	
Issue 5.4.....	11 <sup>th</sup> Aug 2003
➤ Changed ccTalk® to ccTalk throughout the manual.	
➤ Added note about parallel connectors in serial mode. Section <a href="#">19</a> .	
➤ Updated ccTalk commands to match those in TSP073.	
➤ Corrected the diagram in Section <a href="#">6</a> .	
Issue 5.5.....	3 <sup>rd</sup> Dec 2003
➤ Added Stud position ‘E’ to <a href="#">Figure 3</a> .	
Issue 5.6.....	30 <sup>th</sup> June 2004
➤ Changed footer	
Issue 5.7.....	15 <sup>th</sup> October 2004
➤ Added maximum torque settings to the Oval Bezel dimensions.	
Issue 5.8.....	13 <sup>th</sup> Jan 2005
➤ Added frontplate cutout dimensions to <a href="#">Figure 26</a> .	

## 2. Introduction

The SR5 series of coin acceptors has been designed to be compatible with the standard 5" format currently used throughout the vending, amusement and leisure industries.

Through the development of Series Resonance technology, the SR5 incorporates the highest levels of discrimination and functionality. Each acceptor within the series will accept up to 16 different coins or 15 coins plus one token.

Depending on your requirements, the SR5 series can be set-up to be backwards compatible with the C220B, C420, C435, C435 UK AWP and C450. This will be determined by the **Mode**.

- Mode 1 = C435
- Mode 2 = C435 - BACTA Binary
- Mode 3 = C420
- Mode 4 = C435 - Customer Selectable Credit Codes
- Mode 5 = C450/5 BDTA - 12 Coin
- Mode 6 = Custom PCB
- Mode 7 = C435 - Customer Selectable Credit Codes - C420 (Mode3) Inhibits
- Mode 8 = C435 - Customer Selectable Credit Codes - BACTA (Mode2) Inhibits
- Mode 9 = 16 coin BDTA - Custom Credit Codes - Custom Inhibits
- Mode 10 = C220B - Old
- Mode 11 = C220B - New

**(See Manual TSP021 for further interface details).**

As with all new Money Controls products other enhancements have been made to the SR5 series as well as the new sensing technology.

These include:-

- **ccTalk** serial communication. (see sections [18](#) to [21](#))
- Extended **Teach and Run™** options. (see "TSP012 SR5 **MechTool™** Manual")
- Coinless programming.
- Adjustable coin security. (see "TSP012 SR5 **MechTool™** Manual")
- **MechTool™** programmability. (see "TSP012 SR5 **MechTool™** Manual")
- Improved sorter coin detection.

### 3. Operation

Coin discrimination parameters are factory programmed for optimum acceptance of up to 16 different coins or tokens and therefore no field adjustment is necessary beyond token select / **Teach and Run**<sup>™</sup> (see page [29](#)).

However, the SR5 can now be programmed on site without the use of coins and for total flexibility, if a new coin/token is required, the **Teach and Run**<sup>™</sup> function can be used to program all 16 coins and the token position 12.

Coins are inserted into a front or top entry acceptor and roll past a set of Series Resonant sensors. If the characteristics measured from the inserted coin match the stored window readings in all respects, then the coin is recognised as being true. The accept gate will then open and the coin will pass through the accept sensor. Once this happens the SR5 will send a predefined credit signal to the host machine which will correspond to the coin accepted. Depending on the SR5 model configuration the coin may then be diverted to one of 4 different paths or 8 paths if using an active manifold.

If, on comparing the inserted coins characteristics, to all the pre-programmed parameters, the coin readings do not match, this coin will be deemed invalid, the accept gate will remain closed and the coin will travel through to the reject via the reject path. The position of the reject path will be subject to whether a direct reject or indirect reject option has been fitted.

## 4. UK AWP Industry Standard

The UK AWP Standard SR5 is covered in more detail in the SR5 Modes appendix TSP021 (Mode 2).

Basically, this would consist of a Top Entry SR5, Manifold 6, Universal Rundown and Coin Entry Bezel.

*Figure 1: Standard Top Entry configuration using bezel and rundown*

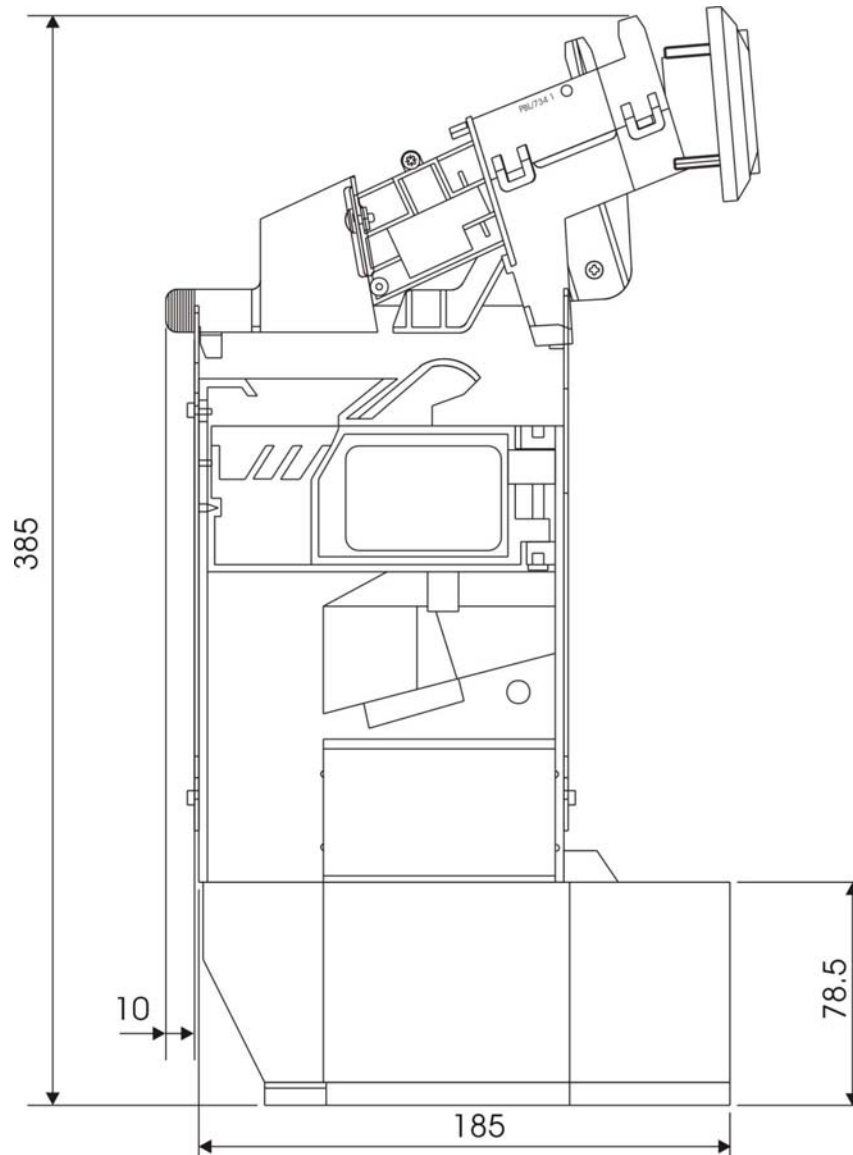

## 5. Electrical Connections

Figure 2: SR5 Connector Side

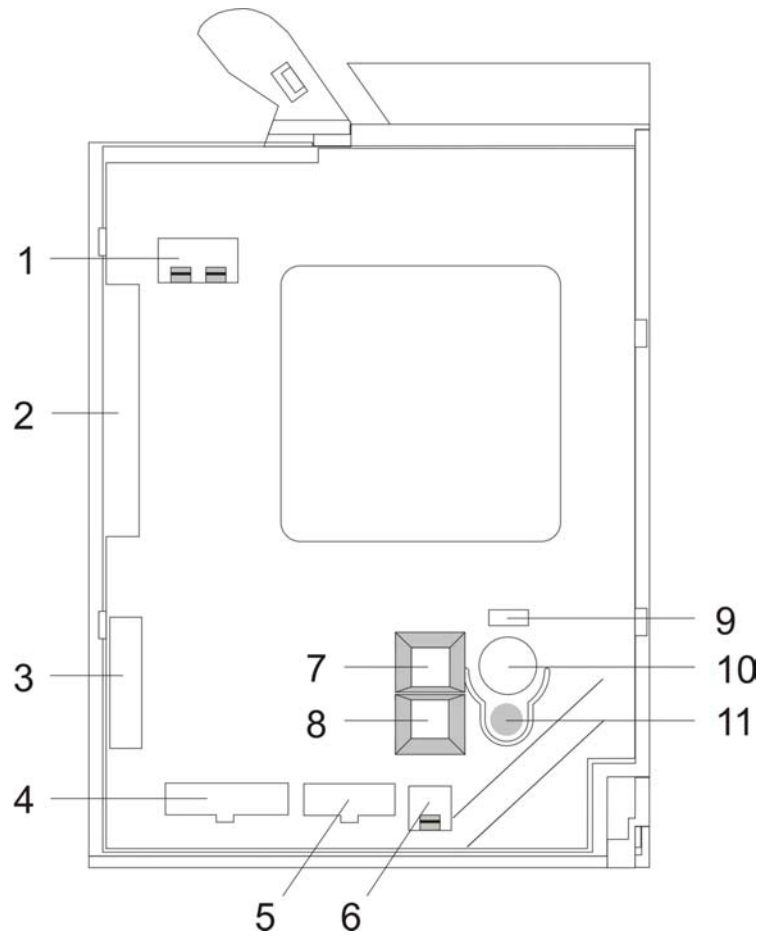

Table 1: SR5 Rear Cover Details.

1	DCE (Dual Coin Entry)	See section <a href="#">9</a> .
2	Parallel Interface	See section <a href="#">10</a> .
3	Sorter Override	See section <a href="#">12</a> .
4	Routing Plug	See section <a href="#">13</a> .
5	Serial interface ( <b>ccTalk</b> )	See section <a href="#">18</a> .
6	Active Manifold	See section <a href="#">14</a> .
7	Diagnostics	See section <a href="#">15</a> .
8	Bank Select Switches	See section <a href="#">16</a> .
9	LED Indicator	
10	Token Select / Function Switch	See section <a href="#">17</a> .
11	Program Button	



## 6. Stud Positions

The stud positions shown below are factory fitted at MCL.  
“A” represents Money Controls back channel compatible.  
“B” represents Industry Standard back channel compatible.  
“C” is a customer specific requested option.  
“D” is a customer specific requested option.  
“E” is a customer specific requested option.

*Figure 3: Stud Positions*

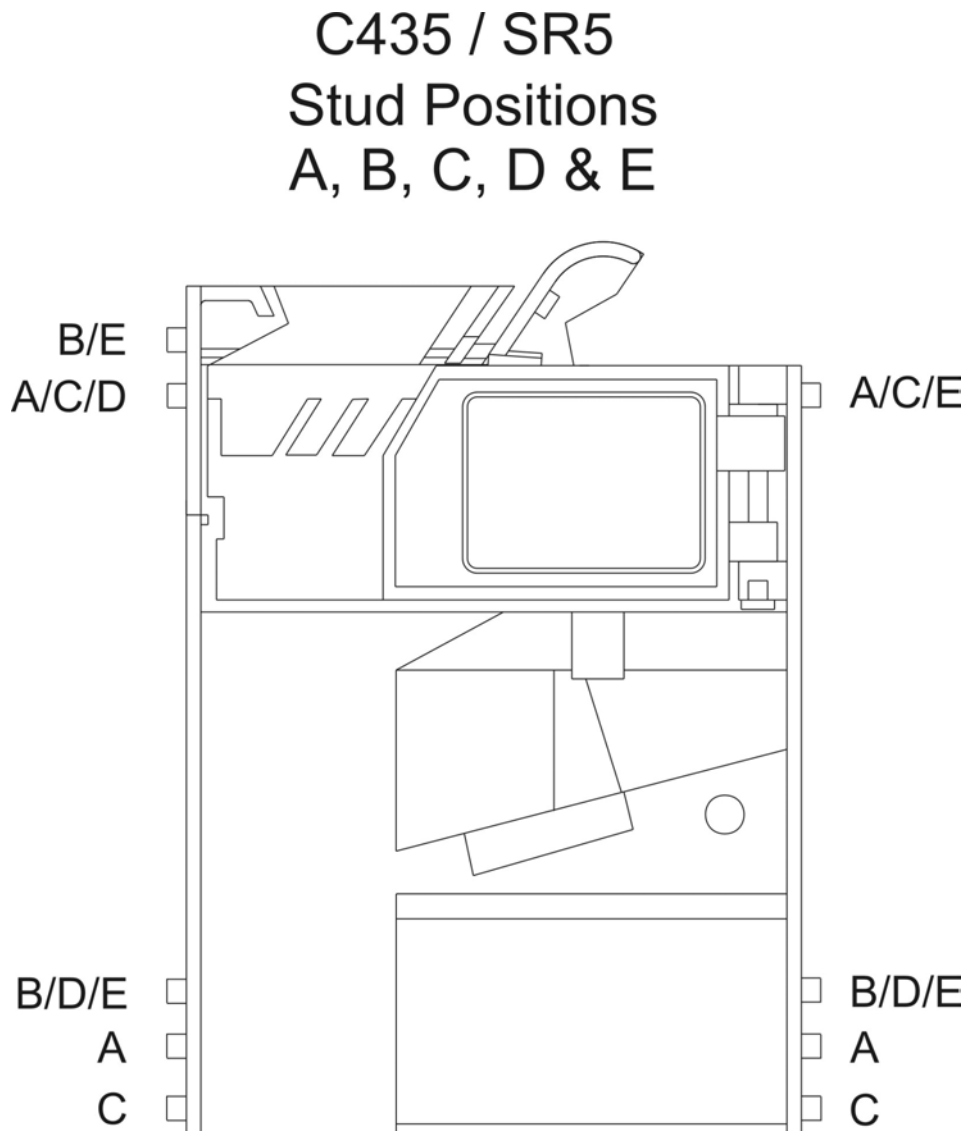

## 7. Electrical Interface Requirements

Table 2: Power Supply

Voltage:	+12V to +24V DC +/- 10%
Absolute (NOT MODE 9):	Min +10V Max +27V
<b>MODE 9 Absolute:</b>	<b>Min +12V Max +40V</b>
Min / Max rise time:	5ms / 500ms (From 0V to within supply range)
Min / Max fall time:	5ms / 500ms (From within supply range to 0V)
Acceptor Power up time:	200 ms from the application of a valid voltage supply. A valid supply must be between the limits specified above.
Ripple voltage [ < 120Hz ]:	< 1 Volt
Ripple voltage [ > 120Hz ]:	< 100mV
Ripple voltage [ > 1KHz ]:	< 20mV

Table 3: Current Consumption

Typical:	70mA
Maximum:	2.0A with sorter. 3.0A with sorter and active manifold.

### 7.1 Accept Common (COM A)

This input is used to select the polarity of the accept signal and to provide the current for any user load, driven by an accept output.

Table 4: COM A DC Input Characteristics

Characteristic	Value	Condition
I leak max	1mA	Off load, i.e. no accept active
I in max	User load +20mA	On load i.e. accept active
V positive max	+24V	Positive Com A
V positive min	5V	Positive Com A
V negative min	0V	Negative Com A
V negative max	-24V	Negative Com A

## 7.2 Standard Inputs

All the following inputs have the same electronic configuration:

- Inhibits
- Bank Select
- Diagnostics
- Overrides
- Select

The hardware configuration for these inputs is shown below:

*Figure 4: Input Hardware Configuration*

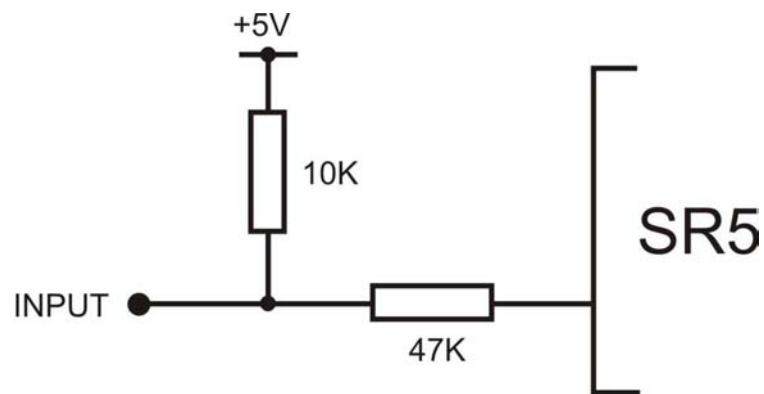

*Table 5: Standard Input DC characteristics*

Characteristic	Value
V in Low (max)	0.75V
V in High (min)	4.25V
I max @ V in Low	0.5mA

## 8. Alarms

When enabled, an alarm condition will activate the accept lines with the binary pattern 10111, (no Accept 4), for 80ms or for as long as the fault exists, depending on the alarm condition.

Conditions that will indicate an alarm condition are:

1. A coin travelling backwards past the inductive sensors which indicates a fraud is being attempted.
2. If the **sorter optos** are blocked for more than 1.5 seconds, the alarm signal will remain active, for the duration of the blockage.

To turn the alarms ON or OFF see page [30](#) '[Alarm and Rundown settings "D"](#)'.

### 8.1 Power-up Diagnostics

When the SR5 powers up, it performs an EEPROM self-check. If there is a problem with the checksum, the LED will turn red and no coins will be accepted.

If diagnostic self check is **enabled**, the following are checked and if there is a problem then the accept lines will show the alarm code, for as long as the fault is present.

- Blockage in the sensor area / faulty sensor.
- EEPROM checksum
- If a sorter is fitted the optics are checked for a blockage.

**Note: If a sorter should be fitted but has been removed, then the SR5 will think the sorter optics are blocked and therefore the alarm condition will be permanent. This can only be rectified by re-fitting a sorter or re-programming the SR5.**

When the blockage / fault is rectified, the alarm code will automatically be removed, except for a checksum error where the power has to be removed and re-applied.

## 9. Dual Coin Entry Rundown Interface (DCE)

*Figure 5: DCE Connector Pin Outs*



This interface is used with the dual coin rundown. It is used to provide information to the SR5 indicating whether a coin or a token has been entered.

Normally, when there is no coin or token in the entry, both the opto detectors are active as they are receiving infrared light from the corresponding emitter. This is the quiescent state.

When a coin or token is entered then the light path between the corresponding emitter and detector is broken and the detector becomes inactive.

Once the coin has passed the optics, the system returns to its quiescent state.

## 10. Parallel Interface

Industry standard interface. Connector type: 21 pin SIL

**This table only shows MODE 1 SR5 details. For other MODE SR5's please refer to manual TSP021.**

Table 6: Parallel Interface

PIN	FUNCTION	ACTIVE	Input (I) / Output(O) / Power(P)
1	Ident	COM A	I/O
2	Accept 5	COM A	O
3	Accept COM (COM A)	+5V to +24V DC 0V to -24V DC	I and P
4	Accept 1	COM A	O
5	Key		
6	Accept 2	COM A	O
7	Accept 3	COM A	O
8	Select	NC / 5V = 5 coin mode. Low = 16 coin mode.	I
9	Accept 4	COM A.	O
10	Inhibit 4	See below.	I
11	+V	12 – 24V DC.	P
12	0V		P
13	Inhibit 3	Inhibit lines MUST be pulled Low, for a coin to be accepted. If the inhibit line is not connected or High, then the selected coin will be rejected.	I
14	Inhibit 2		I
15	Inhibit 1		I
16	Inhibit 5		I
17	Inhibit 6		I
18	Inhibit 7		I
19	Inhibit 8		I
20	Bank Select 1	Low to Inhibit bank <sup>1</sup> .	I
21	Bank Select 2		I

<sup>1</sup> The Bank Select inputs are connected in parallel with the DIL switches on the PCB. The normal state, floating /High, is **Selected** (Bank Enabled).

If the Bank Select DIL switch is set to the ON position **De-selected** (Bank Inhibited) then changing the state of the Bank Select input will have no effect.

If the Bank Select pin on the parallel connector is Low, **De-selected** (Bank Inhibited) then changing the state of the Bank Select DIL switch will have no effect.

### 10.1 Ident Pin

The ident pin (pin 1) can be used by the host machine to identify the SR5 acceptor and hence interpret the binary credit code outputs.

The ident pin is linked on board to COM A and will reflect COM A status providing pin 8, (select), is Low. The ident pin status will change within 10ms of a change in the select line status.

## 10.2 Coin Accept Outputs

These outputs are capable of functioning as current sink, (negative COM A) or current source (positive COM A).

If the value of COM A is outside the specification, then the performance of the Accept outputs is not guaranteed.

On acceptance of a true coin, the transistors (COM A dependant) are turned on for a period of 80ms<sup>(2)</sup> (+/- 5%) to within 1 volt of COM A at a Max. current source/sink of 50mA.

The host machine must look for valid credit pulses NOT LESS THAN 50ms. It is not sufficient to merely detect the edges of credit pulses. This 'de-bounce' will prevent credits being registered by the host machine as a result of any noise or false credit pulses being induced on the output lines.

<sup>(2)</sup> Default time.

*Table 7: Accept output DC characteristics*

<b>Characteristic</b>	<b>Value</b>	<b>Conditions</b>
V out active min.	Com A minus 1V	Positive Com A
V out active max.	Com A plus 1V	Negative Com A
I max (sink or source)	50mA	Positive or Negative Com A
I Leakage	10 $\mu$ A	Off

**Continued:-**

*Figure 6: Accept Outputs*

Com A = Positive with respect to @ V

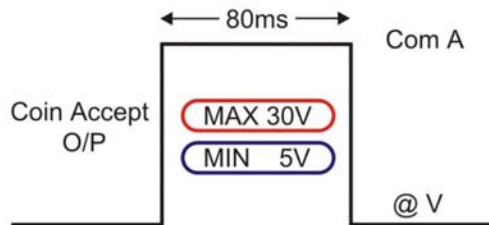
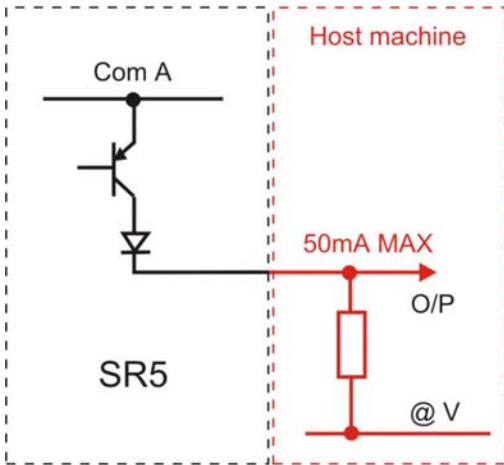

**@ V = Machine off state reference Voltage**

Com A = Negative with respect to @ V

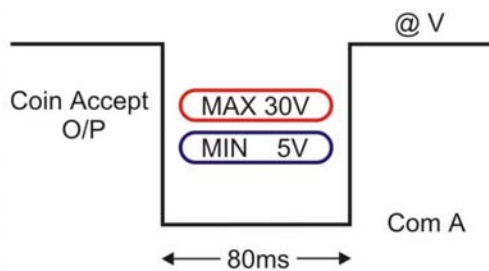
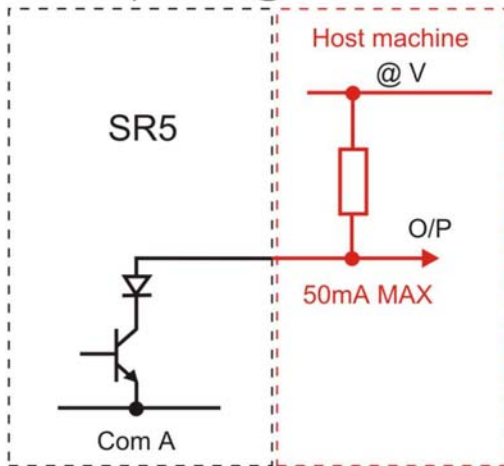

Com A range = -24V to 0V or +5V to +24V

@ V range with respect to Com A = MIN 5V, MAX 30V

**Therefore: Com A = @ V + Pulse V required**

Examples:

- 1). If the host machine's reference is 5V and a +12V pulse is required then Com A = +17V.
- 2). If the host machine's reference is 0V and a -12V pulse is required then Com A = -12V.
- 3). If the host machine's reference is -12V and a +12V pulse is required then Com A = 0V.



### 10.3 Select Input

This input determines whether the SR5 is in 5 coin mode or 16 coin mode. 5 coin mode uses a single output per coin and is therefore limited to 5 different credit codes.

A High will select 5 coin mode whilst a Low will select 16 coin mode.

The **default** condition is High and therefore 5 coin mode.

*Table 8: 5 Coin Mode Accept Outputs (standard – Mode 1)*

Credit Code	Accept 1	Accept 2	Accept 3	Accept 4	Accept 5
1	1	0	0	0	0
2	0	1	0	0	0
3	0	0	1	0	0
4	0	0	0	1	0
5	0	0	0	0	1

#### 5 coin mode credit patterns (1 = Active, 0 = Inactive)

In 16 coin mode a binary pattern is output on the Accept lines using A1, A2, A3 and A5. A4 is used as a strobe to indicate a valid credit pattern.

*Table 9: 16 Coin Mode Accept Outputs (standard – Mode 1)*

Credit Code	Accept 5	Accept 4 (Strobe)	Accept 3	Accept 2	Accept 1
1	0	1	0	0	0
2	0	1	0	0	1
3	0	1	0	1	0
4	0	1	0	1	1
5	0	1	1	0	0
6	0	1	1	0	1
7	0	1	1	1	0
8	0	1	1	1	1
9	1	1	0	0	0
10	1	1	0	0	1
11	1	1	0	1	0
12	1	1	0	1	1
13	1	1	1	0	0
14	1	1	1	0	1
15	1	1	1	1	0
16	1	1	1	1	1

#### 16 coin mode credit patterns

(only valid when Accept 4 is Active. 1 = Active, 0 = Inactive)

\*\* For other SR5 variants, (page 5), please refer to TSP021: \*\*

## 10.4 Inhibit Lines

The Inhibit inputs define whether a programmed coin will be accepted or not. Which coins are affected by the inhibit inputs is decided in conjunction with the Bank Select inputs. (See next section).

If the Inhibit pin is not connected OR High then the corresponding coin will be inhibited i.e. Rejected.

If the Inhibit pin is Low then the corresponding coin will be accepted if deemed to be true.

**Note: The default setting is for ALL inhibit inputs to be High and therefore coins are inhibited.**

## 10.5 Bank Select Parallel Inputs (Modes 1, 4, 7 and 8)

The SR5 is capable of accepting up to 16 different coin types.

Whilst it is possible for the coins to operate entirely independently, for the purposes of inhibiting coins they are arranged in 2 banks of 8.  
It is therefore only necessary to have 8 inhibit inputs (1 per coin in each bank).

Each of the Bank Select inputs controls its relevant bank (1 or 2).

Bank 1 contains coins 1 to 8.  
Bank 2 contains coins 9 to 16.

When a Bank Select input is Low<sup>3</sup>, then the corresponding bank of coins are de-selected (i.e. inhibited).

When a Bank Select input is High<sup>4</sup>, then the corresponding bank of coins are selected (i.e. enabled).

The 8 inhibit inputs only act on the coins in the bank/s that are enabled.

### **Examples.**

When both Bank Select inputs are High then both banks of coins are **selected**. In this state the 8 inhibit lines act on all 16 coins, i.e.

Inhibit 1 controls coin 1 and coin 9.

Inhibit 2 controls coin 2 and coin 10 and so on up to

Inhibit 8 controls coin 8 and coin 16

When Bank Select 1 input is High and Bank Select 2 input is Low then coin Bank 1 is **selected** and coin Bank 2 is **de-selected**, i.e.

Inhibit 1 controls coin 1.

Inhibit 2 controls coin 2 and so on up to

Inhibit 8 controls coin 8.

When Bank Select 1 input is Low and Bank Select 2 input is High then coin Bank 1 is **de-selected** and coin Bank 2 is **selected**, i.e.

Inhibit 1 controls coin 9.

Inhibit 2 controls coin 10 and so on up to

Inhibit 8 controls coin 16.

### **Notes:**

<sup>3</sup> Pulling the Bank Select Low is the same as setting the DIL switch UP (the ON position).

<sup>4</sup> Pulling the Bank Select High is the same as setting the DIL switch DOWN (the OFF position).

## 11. Sorting Coins

**Due to the improvements incorporated in the SR5 4-way sorter, this sorter is not compatible with any of the sorters previously manufactured by MCL and vice versa.**

### 11.1 4-way Sorter

Normally the SR5 will be used to sort coins to one of 4 paths.

(The passive manifold, if fitted, is used to channel the coins into the industry standard footprint).

Sorting can be achieved either using the routing plug (see [Sorting Modes](#) – page 22) or having the paths pre-programmed into EEPROM. Switching between EEPROM and routing plug can be achieved using the rotary switch (see [Routing Plug / EEPROM mode “E”](#)– page 31)

*Figure 7: 4-way sorter paths*

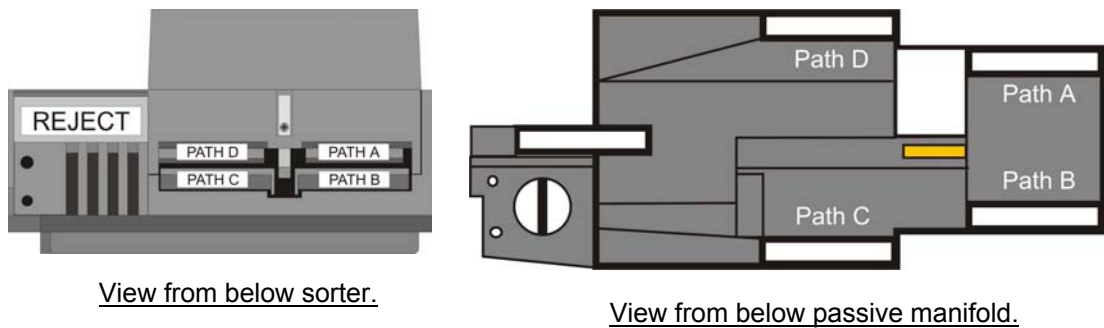

### 11.2 8-way Sorter (Active Manifold)

Other applications require sorting up to 8 different paths. This can be achieved using the active manifold in conjunction with the 4-way sorter. This method can only be used however, if the sorter paths are programmed in EEPROM.

*Figure 8: 8-way Active Manifold sorter paths*

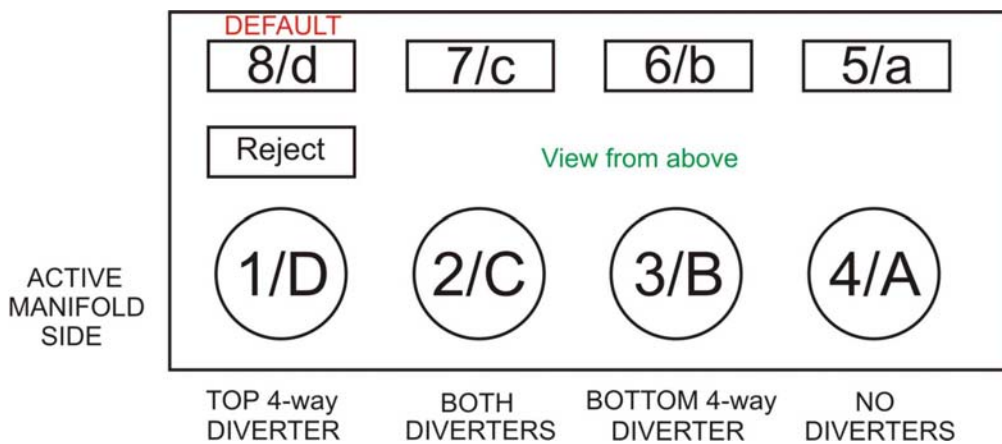

## 12. Sorter Overrides

### 12.1 4-Way Override

Figure 9: Sorter Overrides 4-way

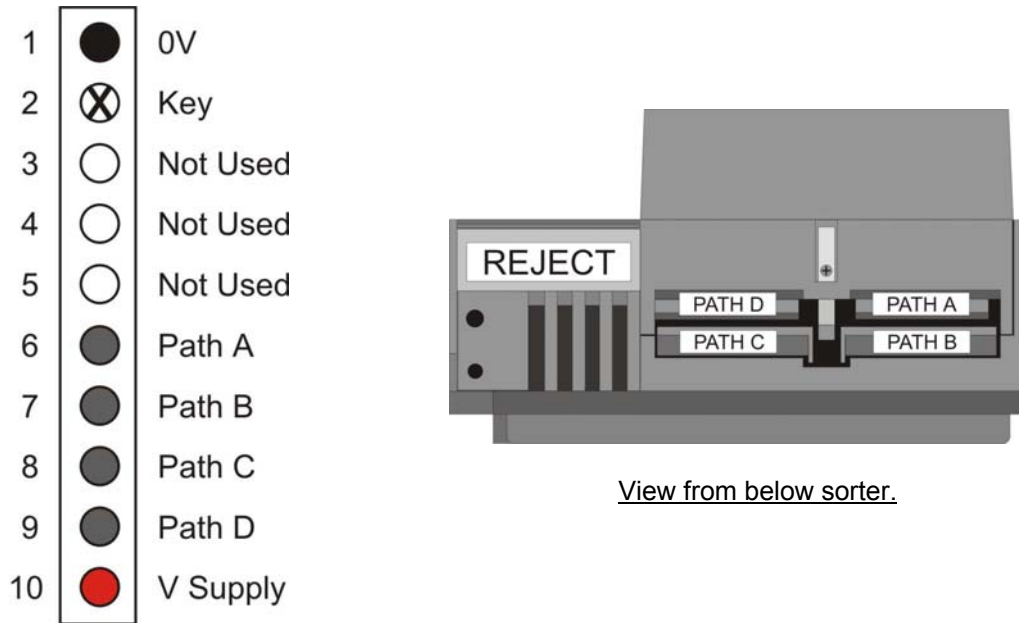

4-way sorting can be achieved either via the routing connector or pre-programmed in EEPROM.

Overrides 1 to 4 control paths A-D (as shown) irrespective of method used.

Taking the relevant input Low indicates to the acceptor that the route is overridden. The coin will then travel down the next programmed/routing connector path or be accepted to the DEFAULT 'A' path.

**Note: Path A can be overridden as long as there is another path for that coin to divert to which has not already been overridden.**

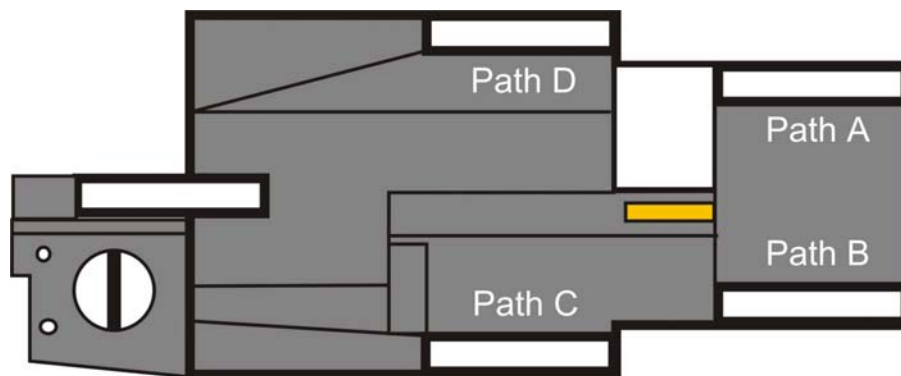

## 12.2 8-Way Override

Figure 10: Sorter Overrides 8-way



In order to use 8-way sorting, the paths **MUST** be programmed in EEPROM. Of the 8 possible routes for an accepted coin, only routes 1 to 7 have a sorter override input. Taking the relevant input **Low** indicates to the acceptor that the route is overridden. The coin will then travel down the next programmed route or be accepted through the **DEFAULT** path.

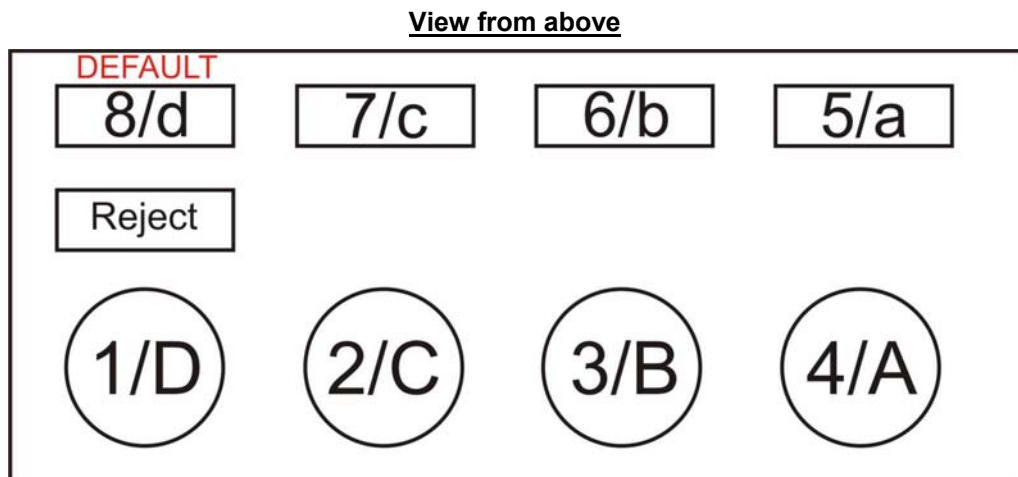

### 13. Sorting Modes

#### 13.1 Routing Plug (4 way sorting only)

The routing connector is an 18-way 0.1” pitch DIL header. Shown below are the coin positions and the sorter paths.

**Note: The default path is A and coin 8 ALWAYS goes to the default.**

**Note: For coins 9 to 16 the paths are the same as coins 1 to 8.**

Figure 11: Routing Plug Connections

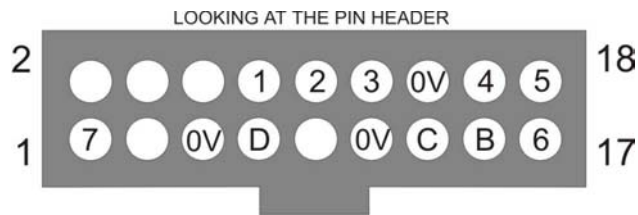

#### 13.2 Using the routing plug

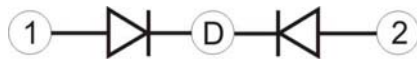

In this example both coins 1 and 2 are diverted to path D. (Any number of coins can be connected like this as long as there is a protection diode - 1N4148 - inserted between the coin position and the path as shown - Cathode to path connection).

**Note: The sequence of sorting using the routing plug is D – C – B – A.**

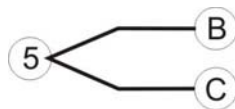

In this example coin 5 will divert to path C then to path B (see above note).

If path B, override to path C is required, path C must first be overridden - coins will sort down path B. When path B is full, the override can be removed from C - coins will sort to path C.

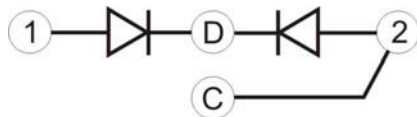

Here, coins 1 and 2 will sort to path D.

If path D is then overridden, coin 1 will sort to DEFAULT (A) and coin 2 will sort to path C.

If path C is then overridden coin 2 will also sort to the DEFAULT (A).

#### 13.3 EEPROM mode (4-way / 8-way sorting)



This mode allows any coin to be sorted to a maximum of 4 paths + the relevant default path.

e.g. 4-way could be coin 2 to path C, then D, B, default A. See [Figure 7](#).

e.g. 8-way could be coin 6 to path 1, then 4, 3, 7, default 8. See [Figure 8](#).

### 14. Active Manifold Interface

*Figure 12: Active Manifold connector*

1		Switched Power
2		Key
3		Power Return

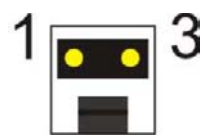

This two pin connector is switched to operate the diverter flap within the active manifold when required as part of 8 way coin sorting.

## 15. Diagnostics

The operation of 3 diagnostics modes are available via connector 7 (Figure 2). The connector has two inputs. If either or both inputs are Low then diagnostics mode can be activated. When both inputs are High – not connected - (inactive) the SR5 is in normal run mode.

To enter diagnostics mode, set the jumpers to perform the required test, set the rotary switch to position 0, then press the program button 11 (Figure 2) until the LED flashes Yellow.

**Note: If the LED stays Green then Diagnostics is not available.**

Two jumpers may be used to select the following modes:

### 15.1 Inhibit/Accept line and Inductive Noise Test

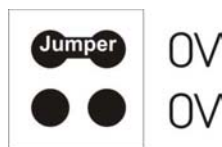

This mode is used for checking inhibit and accept lines in a loop-back test. Only the status of inhibit lines 1 to 6 are used.

**The inhibit line must be Low to activate the corresponding accept line.**

Inhibit 1	⇒	Accept 1
Inhibit 2	⇒	Accept 2
Inhibit 3	⇒	Accept 3
Inhibit 4	⇒	Accept 4
Inhibit 5	⇒	Accept 5
Inhibit 6	⇒	Accept 6
Inhibit 7 and 8	⇒	Not used

The SR5 will also 'clap' the accept gate a number of times, depending on the level of noise present on the sensors. The more 'claps', the more noise.

0 claps	No detectable noise.
1 to 5 claps	Small amount of noise – acceptable.
>5 claps	Unacceptable amount of noise.

**Note: This only happens when the diagnostics mode is first entered. In order to repeat, press the program button, the LED will turn green. Press the program button again until the LED flashes yellow.**



## 15.2 Solenoid and Inductive Sensor Flash Test

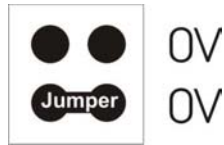

This mode is used for checking the operation of the solenoid drives.

The inhibit line must be Low to activate the corresponding solenoid.

Inhibit 1	⇒	Sorter solenoid 1, Bottom flap
Inhibit 2	⇒	Sorter solenoid 2, Top flap
Inhibit 3	⇒	Manifold solenoid
Inhibit 4	⇒	Accept gate solenoid
Inhibit 5 to 8	⇒	Not used

**Note:- that if there is no sorter fitted then inhibits 1 and 2 will be inactive. Likewise, if the active manifold is not fitted for 8-way sorting, then inhibit 3 will be inactive.**

The SR5 will also show the status of the inductive coils on the accept lines.

An inactive accept line indicates there is a fault.

Accept 1	⇒	Inductive sensor 1 status (Active = OK)
Accept 2	⇒	Inductive sensor 2 status
Accept 3	⇒	Inductive sensor 3 status
Accept 4	⇒	Inductive sensor 4 status
Accept 5	⇒	Inductive sensor 5 status
Accept 6	⇒	On

### 15.3 Opto Test



This mode is used for checking whether the various opto electronic devices used in the product are working correctly.

ON = opto blocked or not fitted.

Accept 1	⇒	DCE coin opto
Accept 2	⇒	DCE token opto
Accept 3	⇒	Sorter optos
Accept 4	⇒	Off
Accept 5	⇒	Off
Accept 6	⇒	Off

The test is interactive, so the optos can be blocked and unblocked with a small piece of card to see if they are working correctly.

The only way to distinguish between a blocked opto – fault – and a missing opto is to physically look for the optic.

**Note: These tests are only useful if the relevant hardware is fitted, i.e. DCE chute and sorter.**

### 15.4 Exit Diagnostics

To exit the diagnostic tests, remove the link/s and press the program button until the LED turns Green.

## 16. Bank Select Switches

There are two bank select switches (one per bank of 8 coins).

These switches operate in parallel with the Bank Select inputs described on page 18 - "[Bank Select Parallel Inputs](#)".

Closing the switch (ON position) is the equivalent of taking the relevant Bank Select input, on the main parallel connector, Low .

If either the switch is closed or the Bank select input is Low, then the bank is de-selected (inhibited).

The Bank Select switch must be in the OFF position (down) AND the corresponding Bank Select input must be High for the bank to be selected (accept coins).

*Figure 13: Bank Select switches*

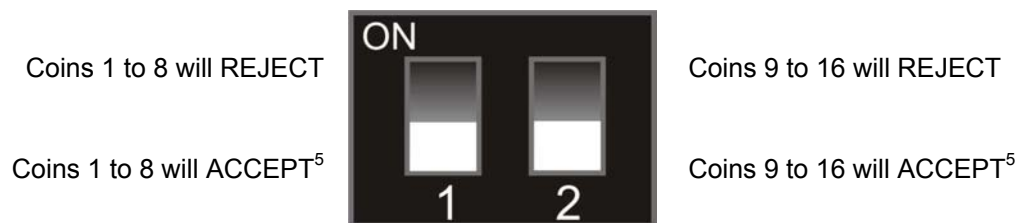

<sup>5</sup> ONLY if the Bank Select input is either not connected or pulled High.

## 17. Rotary Switch Options.

There are a number of options which can be selected via the hexadecimal rotary switch. One function of the rotary switch is to select and program tokens and also carry out basic changes to the SR5 (as discussed below):  
The other function is the “**MechTool™**” access which allows more in depth changes to be made (see “TSP012 SR5 **MechTool™** Manual”).

Figure 14: Rotary switch

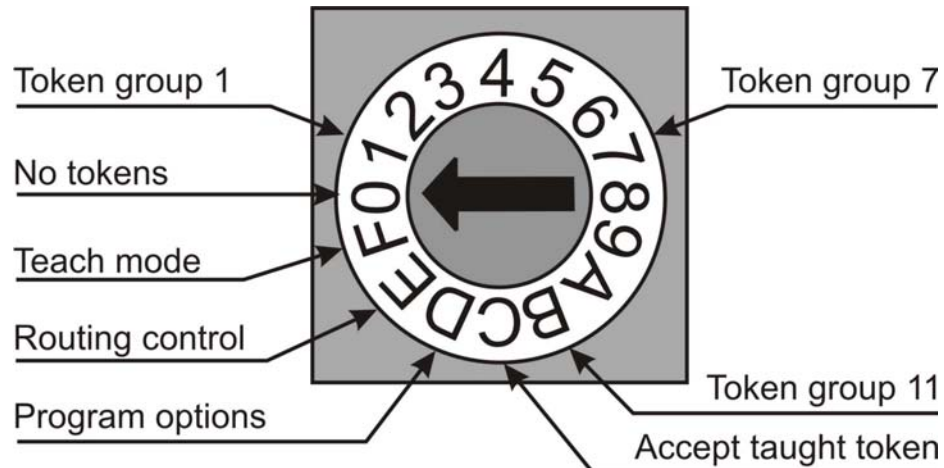

### 17.1 Token Group Selection

Position	Function
0	No token accepted.
1 to B	Selects the required pre-programmed token group, (if available).
C	Selects the 'taught' token (see F)
D	Alarm and Rundown settings. (see page <a href="#">30</a> )
E	Routing plug / EEPROM. (see page <a href="#">31</a> )
F	<b>Teach and Run™</b> a new token. (see page <a href="#">29</a> )

**Note: NEVER leave the acceptor with the rotary switch in positions D, E or F.**

## 17.2 Teach and Run™ Token “F”

Position F allows a token, which is not currently in one of the pre-programmed groups, to be programmed on site.

To **Teach and Run™** a token, ensure that the SR5 is powered up through the main parallel connector (**Teach and Run™ is not available in serial mode**).

Turn the rotary switch to position F.

Press and hold the program button, (situated underneath the rotary switch), the LED will change from Green to Red, release the program button; the LED will flash Yellow and Red.

**Note: If the LED stays Green then Teach and Run™ Token “F” is not available.**

Insert several of the coin type to be taught, typically 8 coins, until the LED flashes Green.

Press the program button, the LED will stop flashing.

Turn the rotary switch to position C, to accept the newly programmed token, press the program button, the LED will turn Red. Release the program button, the LED will return to Green and the new token will be accepted.

If an error occurs during this procedure then the LED will change to Red. Press the program button, the LED will change to Green. The token that was previously programmed will still accept.

To stop programming before the LED changes to flashing Green, press the reject lever, the LED will change to Red. Press the program button, the LED will change to Green. The token that was previously programmed will still accept.

**Note: NEVER leave the acceptor with the rotary switch in positions D, E or F.**

## 17.3 Teach and Run™ Coins

The SR5 allows the teaching of all 16 coin positions.

For further details please see “TSP012 SR5 **MechTool™** Manual”.

## 17.4 Alarm and Rundown settings “D”

For Alarm details see section 8. “Alarms”.

To set these options to those required, ensure that the SR5 is powered up through the main parallel connector. Changes cannot be made in serial mode.

**Note: Make a note of the rotary switch position and the bank select switch positions.**

Turn the rotary switch to position D.

Set the Bank Select switches, to the desired position.

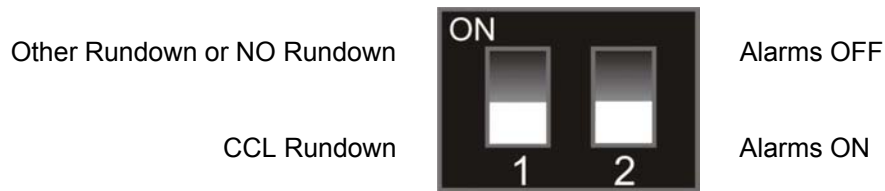

When the desired switch positions are selected press and hold the program button, (situated underneath the rotary switch), the LED will change from Green to Red, release the program button; the LED will change back to Green.

**Note: If the LED stays Green then Alarm and Rundown settings “D” is not available.**

Return the rotary switch and the Bank Select switches to their original positions. Press the program button, the LED will change to Red, release the program button; the LED will change back to Green.

**Note: NEVER leave the acceptor with the rotary switch in positions D, E or F.**

## 17.5 Routing Plug / EEPROM mode “E”

The SR5 allows you to change from EEPROM mode (factory programmed sorting configurations) to routing plug mode and from routing plug mode to EEPROM mode.

To set this option, ensure that the SR5 is powered up through the main parallel connector. Changes cannot be made in serial mode.

**Note: Make a note of the rotary switch position and the bank select switch positions.**

Turn the rotary switch to position E.

Set Bank Select switch 1, to the desired position.

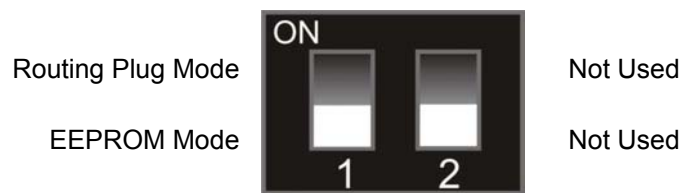

When the desired switch positions are selected press and hold the program button, (situated underneath the rotary switch), the LED will change from Green to Red, release the program button; the LED will change back to Green.

**Note: If the LED stays Green then Routing Plug / EEPROM mode “E” is not available.**

Return the rotary switch and the Bank Select switches to their original positions. Press the program button, the LED will change to Red, release the program button; the LED will change back to Green.

**Note: NEVER leave the acceptor with the rotary switch in positions D, E or F.**

## 18. Label Details

Figure 15: SR5 Label Details

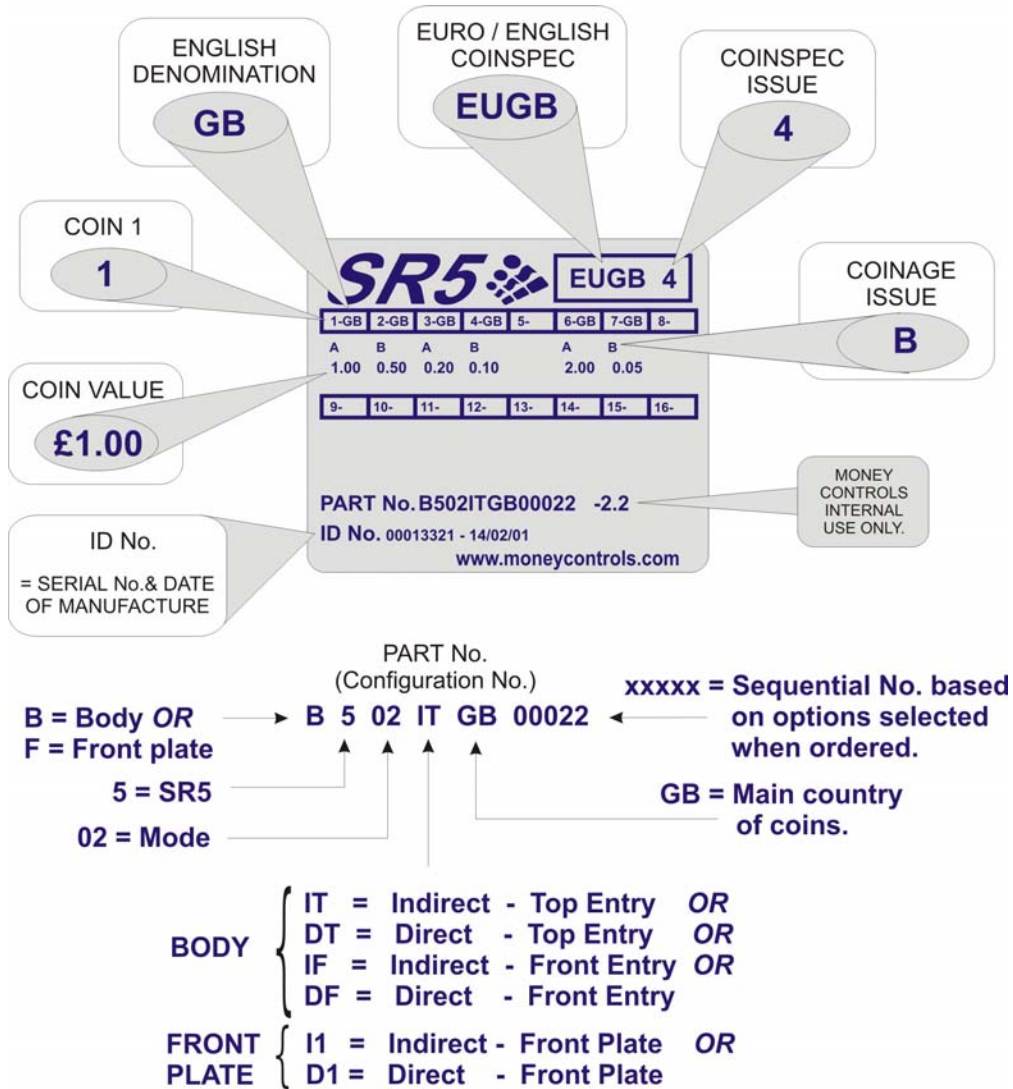

### New Label Details

Model : As per Configuration Number Above.

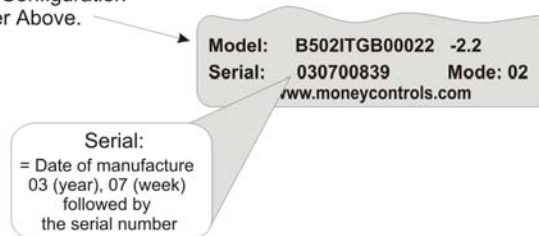



## 19. ccTalk Protocol

### **Warning:**

**While in SERIAL mode, the PARALLEL connectors are DISABLED.**

### 19.1 Serial Interface

The serial interface is used to program coin data and customer options. It can also be used instead of the parallel interface to communicate with the machine.

**Note: The serial and parallel interfaces cannot be used together in the machine.**

Protocol: ccTalk BACTA compliant implementation.

For further details on this section please refer to the current ccTalk generic standard.

Connector type: 10 Way DIL (connector 5 on [Figure 2](#)).

Pin 1	- DATA	
Pin 2	- 0V	[Not used]
Pin 3	- Not used	
Pin 4	- 0V	[Not used]
Pin 5	- /RESET	
Pin 6	- Not used	
Pin 7	- +12 to +24 Volts	[Power]
Pin 8	- 0 Volts	[Power]
Pin 9	- /Serial Mode	
Pin 10	- Reserved	

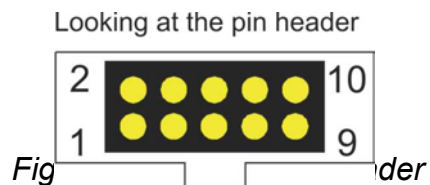

*Pin 9* is used to signal to the mech. that the serial interface is to be used rather than the parallel interface. For serial mode, pin 9 = Low - **at POWER-UP.**

*Pin 5* is an optional hardware-reset line to the mech. and other peripherals on the bus.

**Note: Pins 2 and 4 are connected to 0 Volts.**

## 20. ccTalk Serial Messages

Table 10: *ccTalk Serial Commands*

Header	Function	Header	Function
254	Simple poll	214	Write data block
253	Address poll	213	Request option flags
252	Address clash	212	Request coin position
251	Address change	210	Modify sorter paths
250	Address random	209	Request sorter paths
249	Request polling priority	202	Teach mode control
248	Request status	201	Request teach status
247	Request variable set	199	Configuration to EEPROM
246	Request manufacturer id	197	Calculate ROM checksum
245	Request equipment category id	196	Request creation date
244	Request product code	195	Request last modification date
243	Request database version	194	Request reject counter
242	Request serial number	193	Request fraud counter
241	Request software revision	192	Request build code
240	Test solenoids	189	Modify default sorter path
238	Test output lines	188	Request default sorter path
237	Read input lines	185	Modify coin id
236	Read opto states	184	Request coin id
233	Latch output lines	183	Upload window data
232	Perform self-test	182	Download calibration information
231	Modify inhibit status	181	Modify security setting
230	Request inhibit status	180	Request security setting
229	Read buffered credit or error codes	179	Modify bank select
228	Modify master inhibit status	177	Handheld function
227	Request master inhibit status	176	Request alarm counter
226	Request insertion counter	173	Request thermistor reading
225	Request accept counter	170	Request base year
222	Modify sorter override status	169	Request address mode
221	Request sorter override status	162	Modify inhibit & override registers
219	Enter new PIN number	4	Request comms revision
218	Enter PIN number	3	Clear comms status variables
216	Request data storage availability	2	Request comms status variables
215	Read data block	1	Reset device

For further details on this section please refer to the current **ccTalk** generic standard or contact Money Controls Technical Services Department.

## 20.1 ccTalk Error Codes

Table 11: *ccTalk Error Codes*

Code	Error
1	Reject coin
2	Inhibited coin
3	Multiple window ( ambiguous coin type )
6	Accept sensor timeout
8	2nd close coin error ( coin insertion rate too high )
14	Accept sensor blocked
15	Sorter opto blocked
17	Coin going backwards
23	Credit sensor reached too early
24	Reject coin ( repeated sequential trip )
25	Reject slug
35	Number of coin meter pulses overloaded
36	Games overloaded
254	Coin return mechanism activated ( flight deck open )

## 20.2 ccTalk Fault Codes

Table 12: *Fault Codes*

Code	Fault
1	EEPROM checksum corrupted
2	Fault on inductive coils
3	Fault on credit sensor
4	Fault on piezo sensor
8	Fault on sorter exit sensors
22	Fault on thermistor
34	Temperature outside operating limits

## 20.3 ccTalk Status Codes

Table 13: *Status Codes*

Code	Status
1	Coin return mechanism activated ( flight deck open )

## 21. ccTalk Interface Circuits

### 21.1 Circuit 1 – ccTalk Standard Interface

This circuit uses an open-collector transistor to drive the data line and a diode protected straight-through receiver.

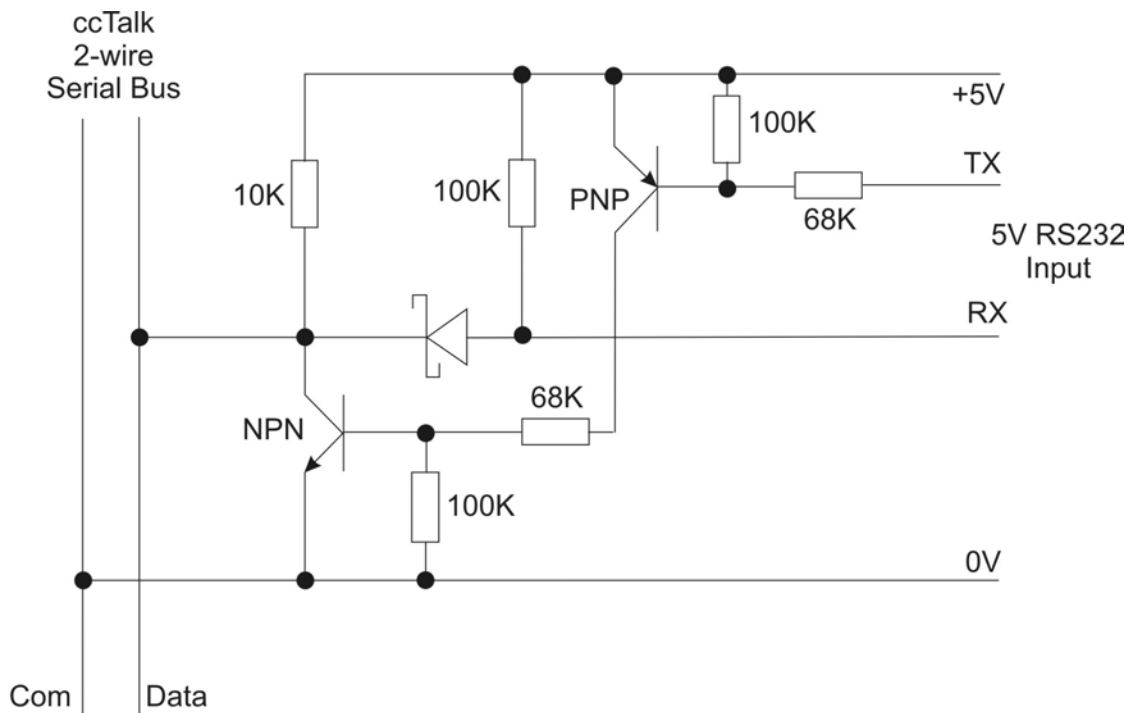

Figure 17: Circuit 1, **ccTalk** Standard Interface

#### Typical Components

Diode	BAT54	Schottky Diode, low forward voltage drop.
NPN	BC846B	High gain, medium signal, NPN transistor.
PNP	BCW68	High gain, medium signal, PNP transistor.

## 21.2 Circuit 2 – ccTalk Low Cost Interface

Assuming that the transmitting device is capable of sinking a reasonable amount of current, a direct diode interface can be used rather than a full transistor interface. Although cheaper to implement, this circuit does not have the drive capability or the robustness of other designs.

Figure 18: Circuit 2, **ccTalk** Low Cost Interface

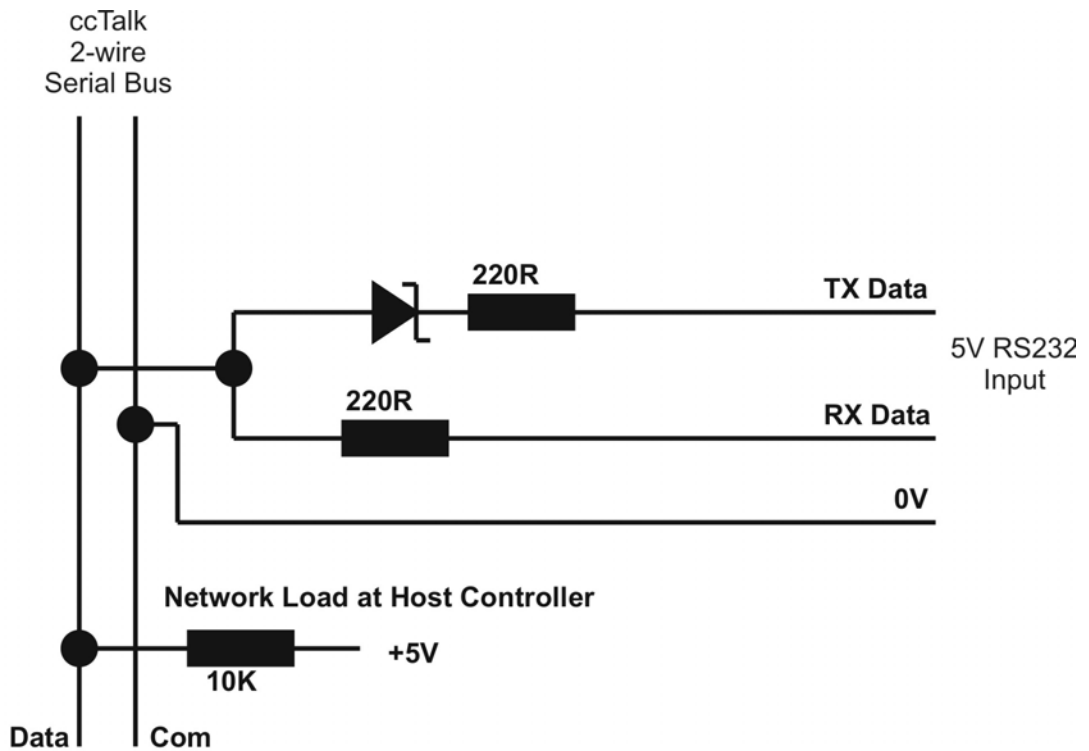

### 21.3 Circuit 3 – ccTalk Direct Interface

A very low cost solution is to interface a single pin on a microcontroller directly onto the **ccTalk** data line. The pin can be switched between active-low for transmitting and high-impedance tri-state for receiving.

Figure 19: Circuit 3, **ccTalk** Direct Interface

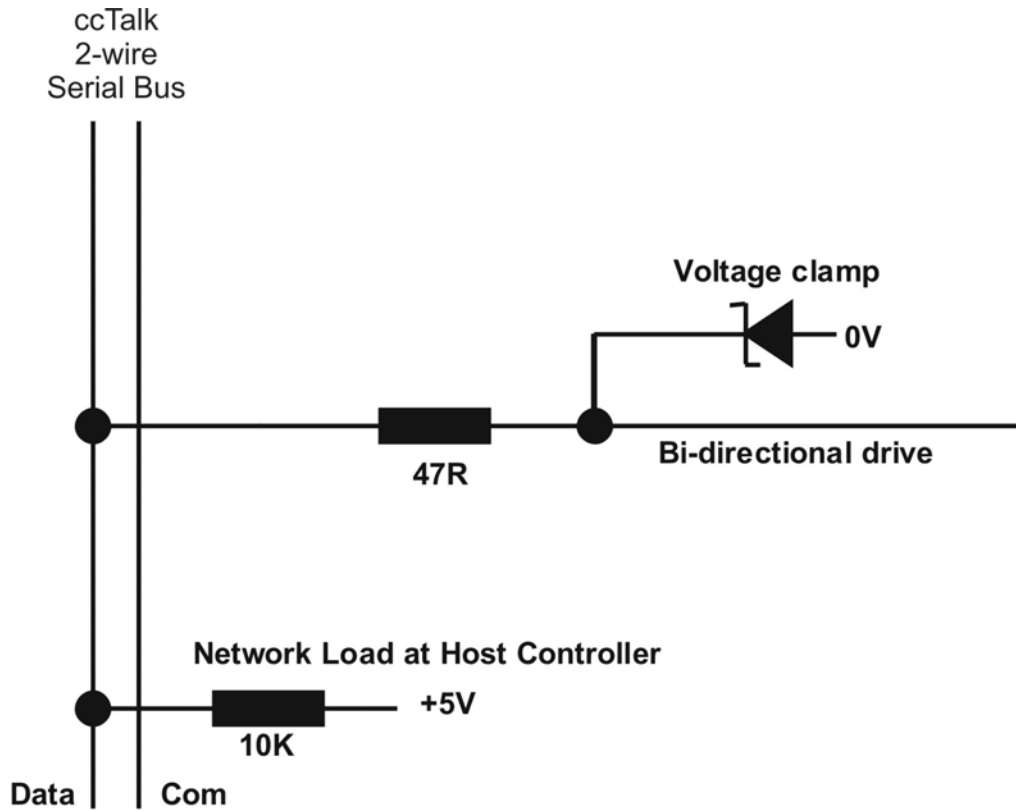

### 21.4 Circuit 4 – ccTalk PC Interface

The circuit below shows how to connect the 9-pin serial port of a PC to the **ccTalk** data bus. The only integrated circuit required is a Maxim level-shifter which operates off a single +5V supply. Any small-signal diodes and transistors can be used.

Figure 20: Circuit 4, **ccTalk** PC Interface

# PC Interface Circuit

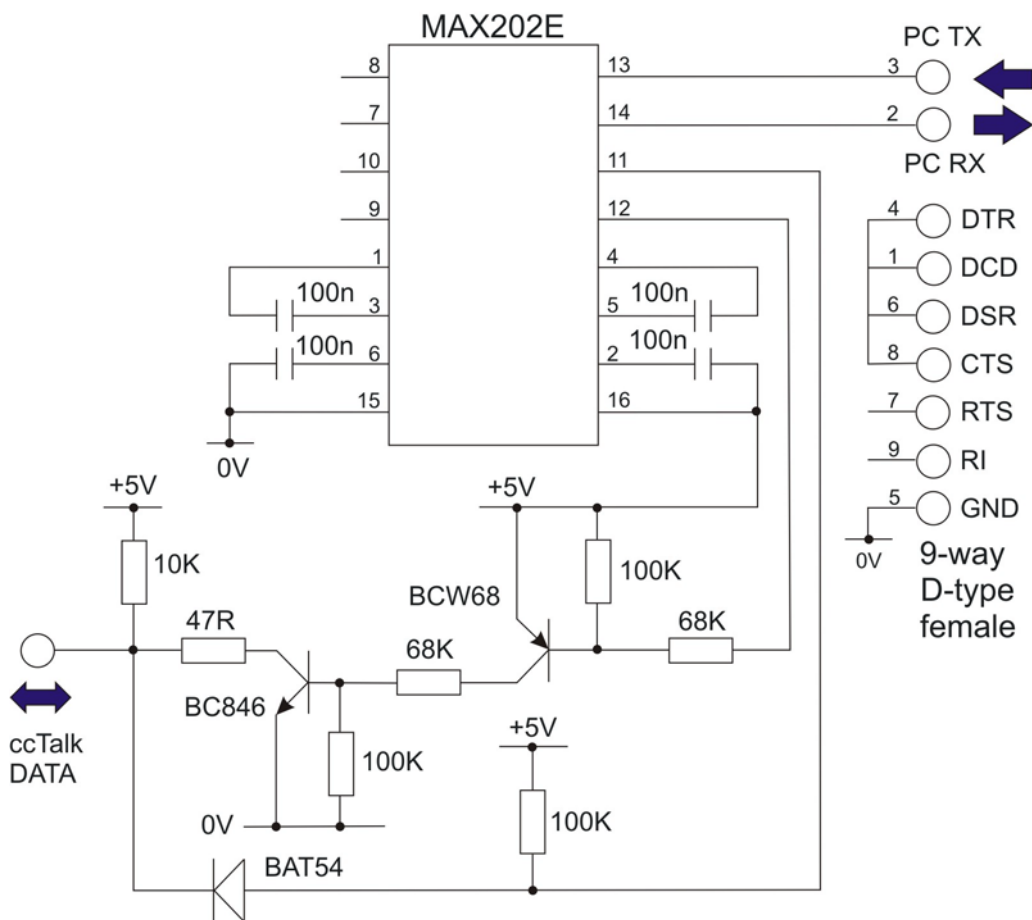

## 22. Servicing

Please refer to [Figure 28](#) for parts details.

### 22.1 Front Entry - Removal and Refitting

To remove the body from the frontplate, first unplug any interface connectors from the SR5. Pull back catch (1) and lift the body upwards (2). When the stop position is reached the body can be withdrawn away from the frontplate (3).

When re-assembling, line up the keyhole slots in the body with the retainers on the frontplate. Push the body forward and downwards.

When in position, catch (1) will click into the locking slot.

Re-connect all the interface connectors.

*Figure 21: Front Entry Removal Diagram*

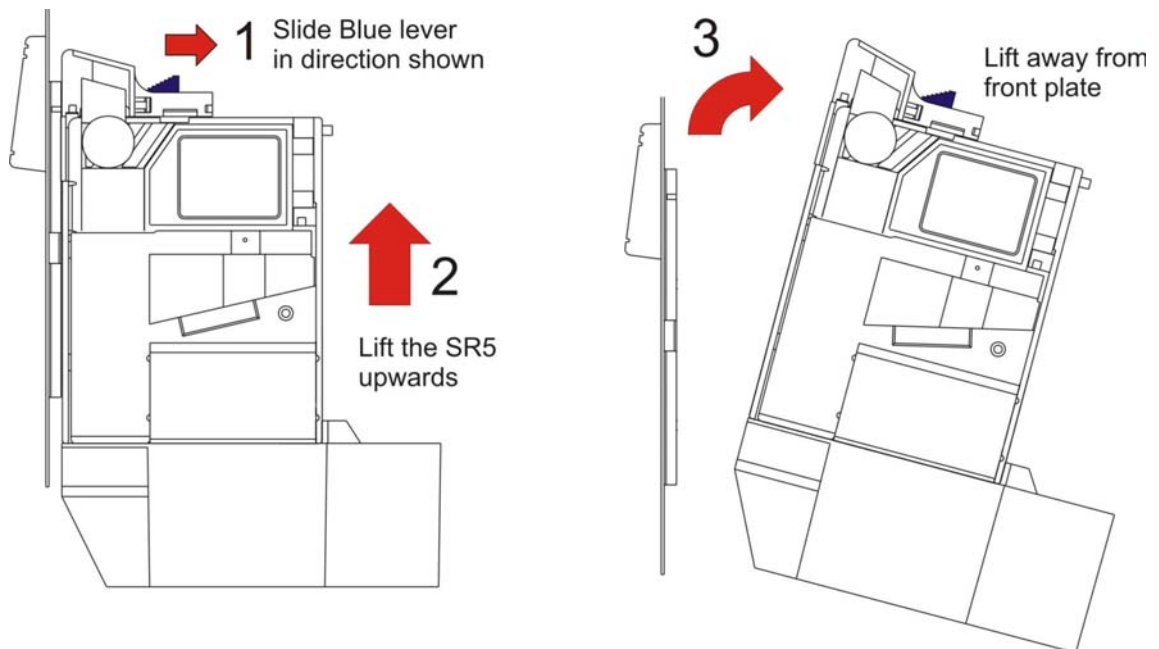

### 22.2 Top Entry - Removal and Refitting

Release the locking catches and carefully lift out the acceptor from the back channel. Once the machines harness becomes accessible, remove all the interface connectors.

Refitting the acceptor is the reverse of removal.



### 22.3 Cleaning

The coin rundown area should be cleaned regularly to ensure accurate discrimination of coins and tokens. Only a damp cloth should be used.

Under NO circumstances should any solvent, abrasive or foam type cleaner be used.

Access to the coin rundown is gained by opening the reject gate.

### 22.4 Accept Gate

Please refer to [Figure 28](#).

To detach the accept gate, first undo screw (9) and remove the rundown cover. Carefully slide the gate spring (12) towards the rear of the SR5 and remove. Pull the gate forward and downward to remove.

Re-fitting is the reverse of removal.

Take extreme care when re-fitting the accept gate spring.

### 22.5 Sorter

Please refer to [Figure 28](#).

Removal and Re-fitting.

Undo screw (9) and remove the rundown cover. The sorter can be unplugged and withdrawn.

When re-assembling, ensure the sorter flaps are correctly fitted and not trapped.

### 22.6 Rear Cover

No User serviceable parts.

Access to all switches is achievable without removing the cover. Therefore the cover should only be removed by approved service centres.

## 23. Fault Finding

The following information is presented for customers' guidance in rectifying a fault but does not cover all possible causes.

All acceptors with electronic faults should be returned to Money Controls Ltd. or to an approved service centre for repair.

Symptom	Investigate	Possible Cause
Acceptor does not work (all coins reject).	Connector.	Poor contact. Loose wire.
	Power supply.	Not switched on. Incorrect voltage. Inadequate current. Rise time too slow.
	Inhibit inputs.	Acceptor inhibited.
	Accept gate.	Gate not free or dislocated.
	Accept channel.	Obstructed.
	Reject gate.	Not fully closed.
	LED on rear cover is RED.	EEPROM checksum error <sup>6</sup> . SR Sensor faulty <sup>7,8</sup> . Credit sensor faulty <sup>7,8</sup> . Credit sensor blocked <sup>7</sup> . Sorter faulty <sup>7,8</sup> . Sorter blocked <sup>7</sup> .
LED on rear cover is YELLOW.	Remove the power and re-apply. LED should be green.	
Poor acceptance of true coins.	Power supply	Voltage less than 10V. (NB voltage drops when solenoid/s are activated).
	Accept gate.	Gate not free or dislocated.
	Connector.	Loose.
	Coin rundown.	Dirty.
Coins stick or jam in acceptor.	Bank select switches.	Both switches are DOWN and both banks are programmed with the same coins.
	Rundown. Accept channel. Accept gate. Reject gate.	Dirty or mechanical damage.
One of the true coin types always rejects.	Interface.	Damaged interface cable.
	Inhibit status.	Coin inhibited.
	Label.	Coin not programmed.
Coins in wrong cash box.	Sorter.	Dirty, damaged or obstructed.
		Broken wire.
		Sorter flap dislocated.
	Main unit.	Incorrect sorter paths programmed.
		Faulty/wrong routing plug.
		No routing plug fitted.
		Wrong routing mode.
Incorrect overrides selected.		
No accept signal.	Connector.	Loose or broken wire.
	Accept channel.	Dirty or obstructed. (acceptor time-out)

<sup>6</sup> This condition requires the SR5 to be reprogrammed.

<sup>7</sup> These faults will only be seen if 'Power-up Diagnostics' is ON.

<sup>8</sup> These faults require to SR5 to be returned for repair.

## 24. Mechanical Specification

### 24.1 Position

The SR5 should be mounted within  $\pm 2$  degrees of the vertical in any plane. It is intended for use in stationary environments.

### 24.2 Coin/Token Sizes

The accepted range of coin sizes are shown below:

This Graph is only intended as a guide. If a coin is required that is close to the limits shown, please check with Money Controls Technical Services department first.

*Figure 22: SR5 Accepted Coin Dimensions Graph*

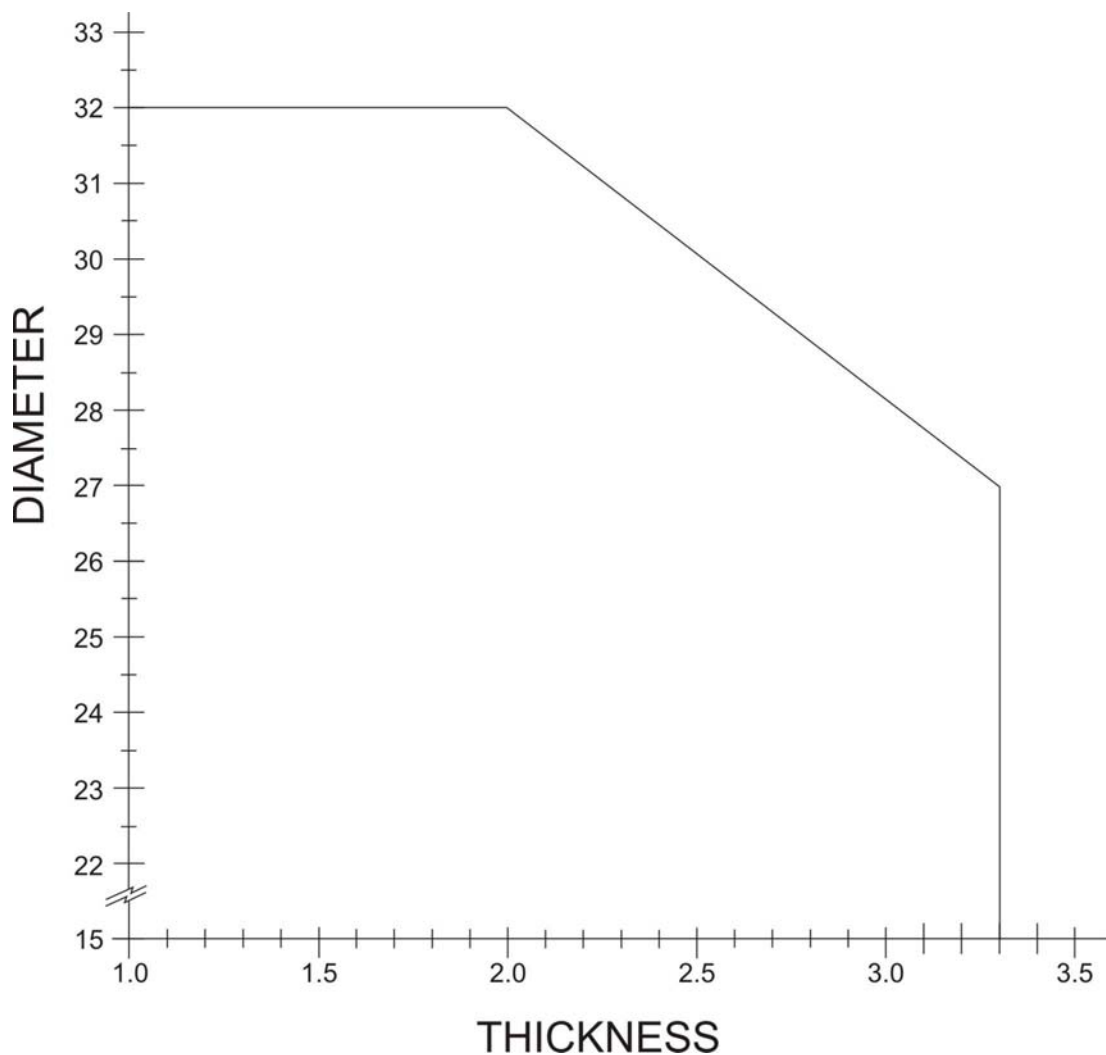

## 24.3 Specified EMC Performance

### 24.31 EMISSIONS

This product is compliant with EMC test specification EN55022; 1998

### 24.32 IMMUNITY

This product is compliant with EMC test specification EN55014-2; 1997

### 24.33 SHOCK / VIBRATION IMMUNITY

This product is compliant with BS 2011 part 2.1. [ IEC 68-2-27 ]

## 24.4 Environmental specification

*Table 14: Environmental Ranges*

Operating temperature range:	0°C to 55°C non-condensing	10% to 75% RH
Storage temperature range:	-20°C to 70°C non-condensing	5% to 95% RH non-
(Recovery time by the acceptor after a temperature step change is 1 hour per 20°C. Maximum operating rate of change 20°C per hour.)		

## 24.5 Material Flammability Rating

The major plastic part of the SR5 (the body) is rated as	UL94-V0
The other parts are rated as	UL94-HB
The 8-way manifold is rated as	UL94-HB

## 24.6 Top Entry dimensions

Figure 23: SR5 Top Entry with Sorter Dimensions

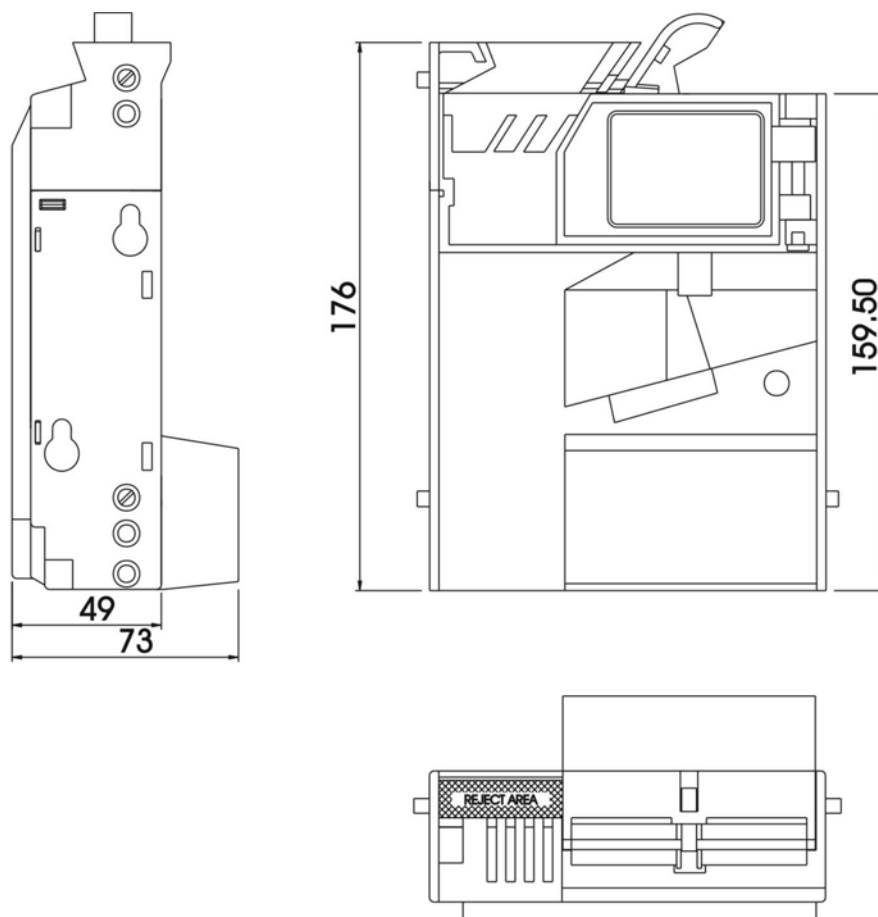

## 24.7 Bezel Dimensions

Figure 24: Oval Bezel Dimensions

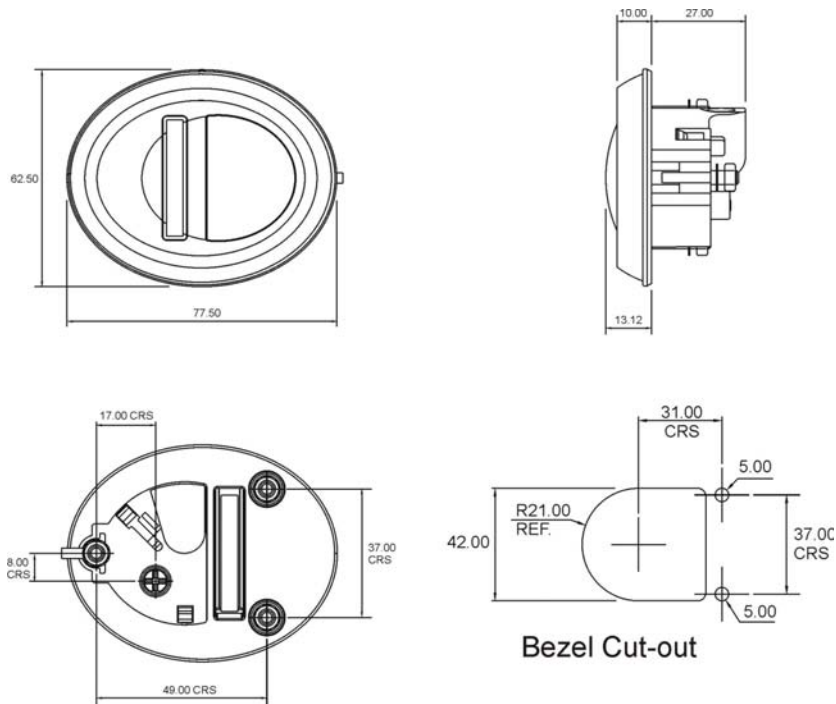
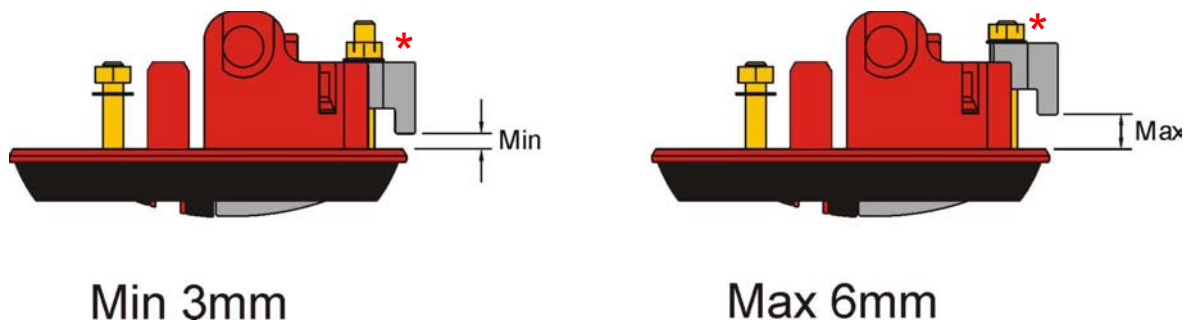

Figure 25: Panel Fixing Dimensions



\* Please note when tightening the fixing nut a max torque setting (0.75 N/m) must not be exceeded

### 24.8 Front Entry Dimensions

Figure 26: SR5 Front Entry Dimensions

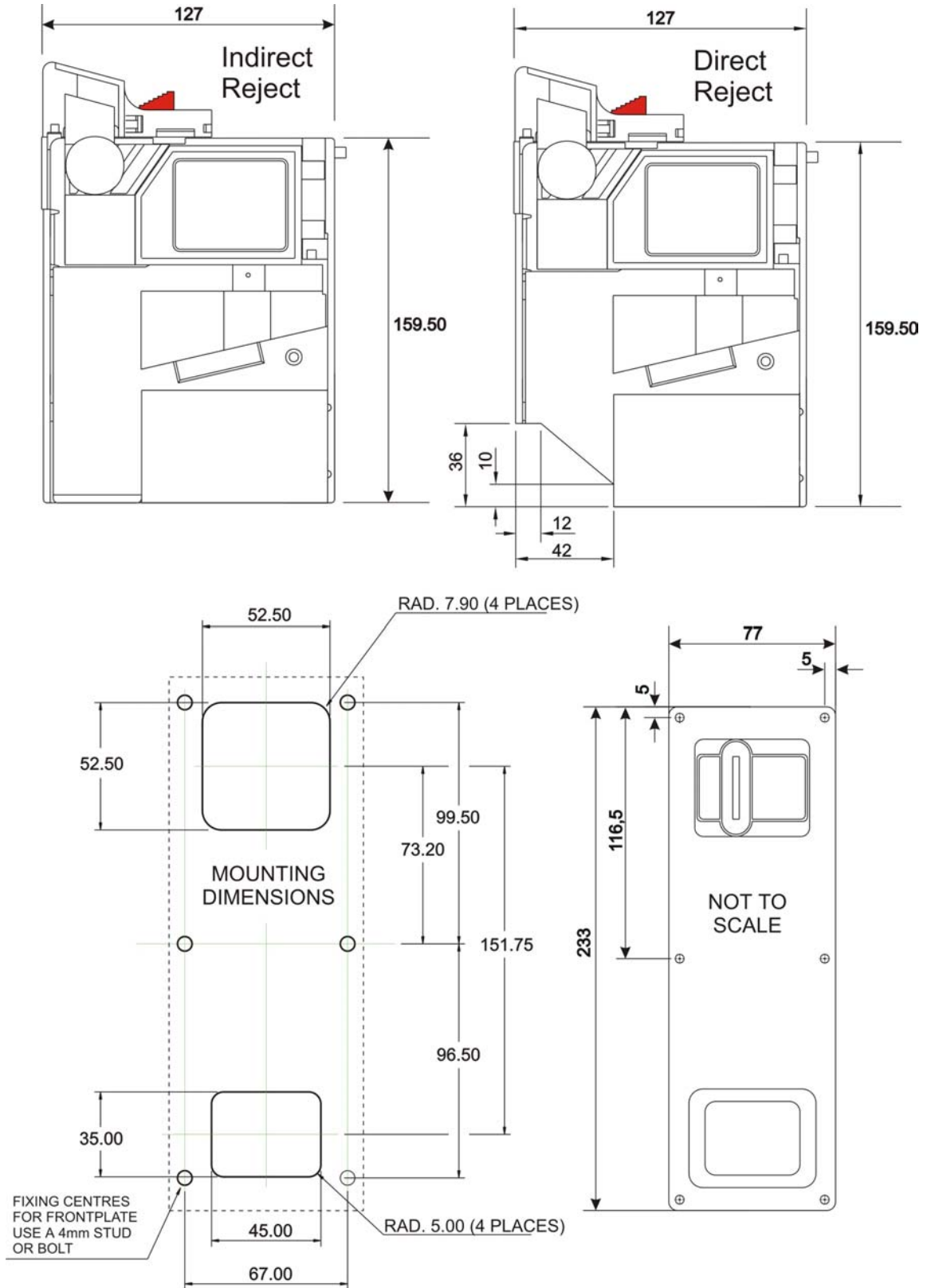

## 24.9 Manifold Coin Exit Paths

Figure 27: SR5 Manifold Coin Exit Paths

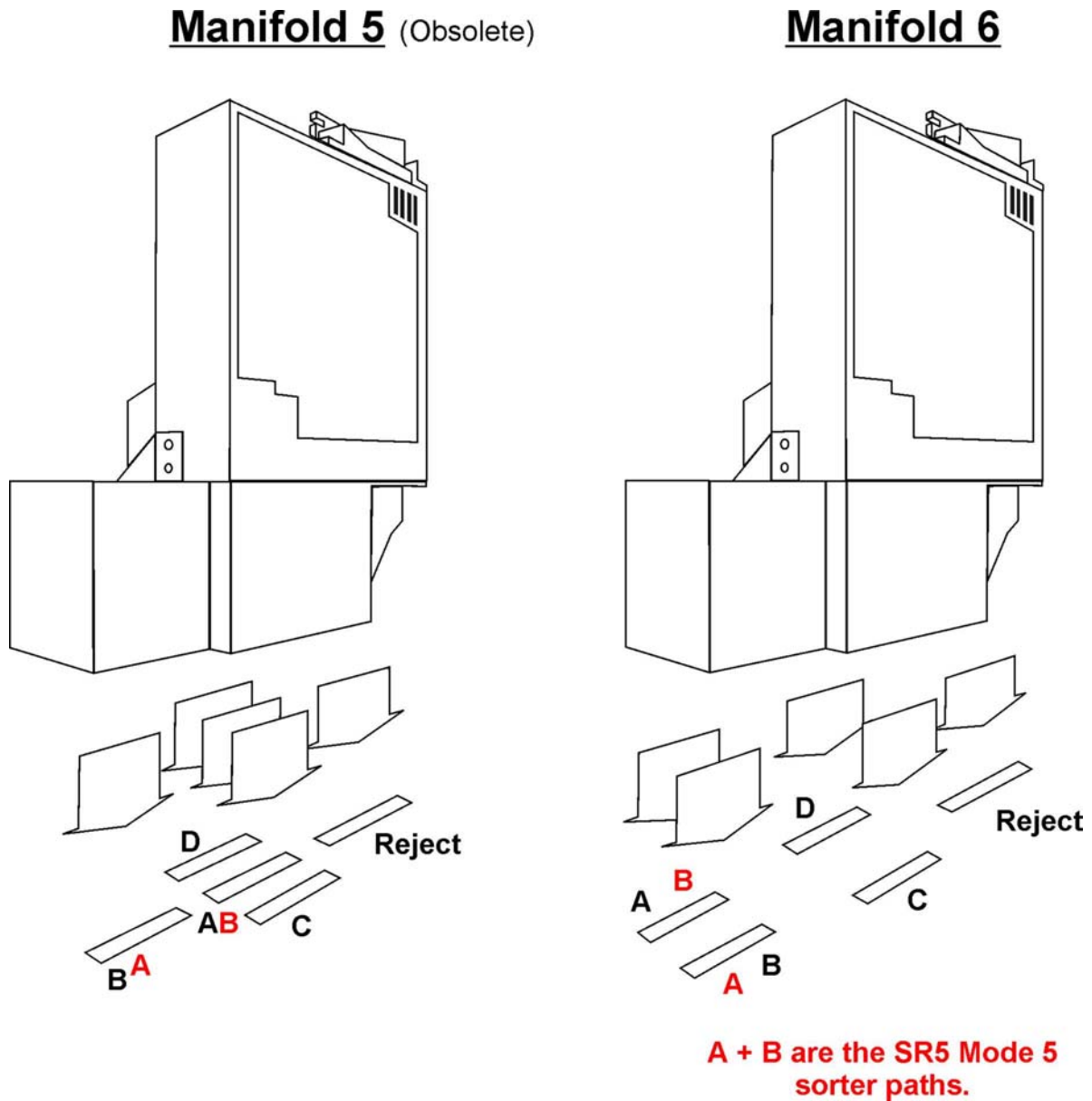

Note:- C235, C255, C335 and SR5 Mode 5 have the same sorter paths (Red + Black).  
C435 and all the other SR5's fitted with a sorter are as above (Black only).  
Manifold 5 is an OBSOLETE product and is only here for reference.



Figure 28: Top Entry / Front Entry Exploded View

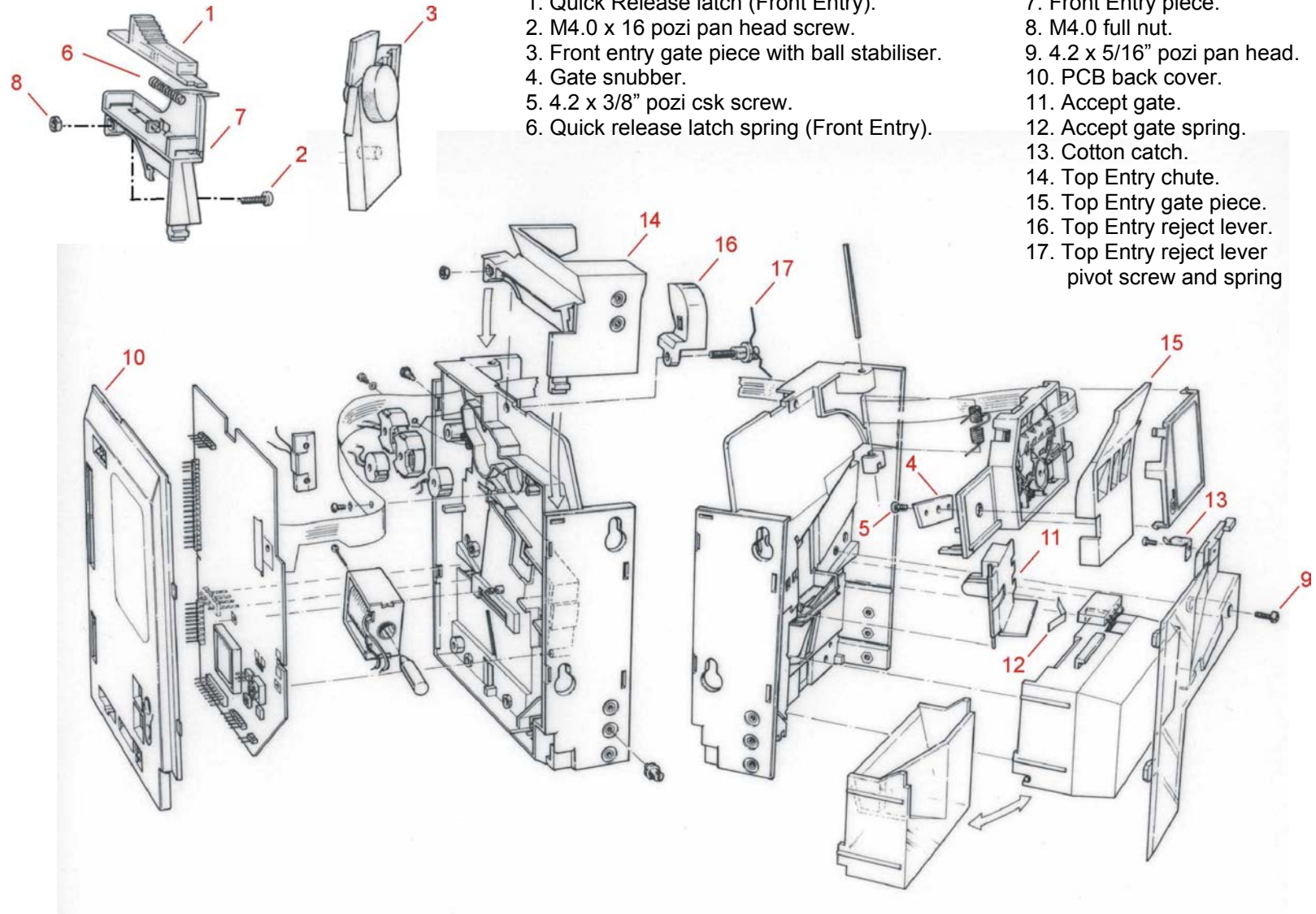

This manual is intended only to assist the reader in the use of this product and therefore Money Controls shall not be liable for any loss or damage whatsoever arising from the use of any information or particulars in, or any incorrect use of the product. Money Controls reserve the right to change product specifications on any item without prior notice.