

# Compact Hopper Technical Manual



This document is the copyright of Money Controls Ltd and may not be reproduced in part or in total by any means, electronic or otherwise, without the written permission of Money Controls Ltd. Money Controls Ltd does not accept liability for any errors or omissions contained within this document. Money Controls Ltd shall not incur any penalties arising out of the adherence to, interpretation of, or reliance on, this standard. Money Controls Ltd will provide full support for this product when used as described within this document. Use in applications not covered or outside the scope of this document may not be supported. Money Controls Ltd. reserves the right to amend, improve or change the product referred to within this document or the document itself at any time.

**Contents:**

<b>1. Diary of Changes</b> .....	<b>4</b>
<b>2. Introduction</b> .....	<b>5</b>
<b>3. Safety Note</b> .....	<b>6</b>
<b>4. Product Overview</b> .....	<b>7</b>
4.1 Operation .....	7
4.2 Coin Routing.....	7
<b>5. Mechanical Features</b> .....	<b>8</b>
5.1 Hopper Dimensions .....	8
5.2 Hopper Weight.....	8
5.3 Coin Size Range.....	8
5.4 Coin Capacity .....	8
<b>6. Electrical Features</b> .....	<b>9</b>
<b>7. Overall Dimensions</b> .....	<b>10</b>
7.1 High Capacity Bowl.....	12
7.2 Splashguard .....	13
7.3 Rear Exit Chutes.....	14
<b>8. Installation and Removal</b> .....	<b>17</b>
8.1 Dismantling the hopper.....	17
8.2 Securing the hopper base.....	17
8.21 Using the 4mm Holes .....	17
8.22 Using the keyholes .....	17
8.3 Hopper Assembly .....	17
8.4 Coin Spillage .....	17
<b>9. Electrical Interface</b> .....	<b>18</b>
9.1 Interface Options .....	18
9.2 Interface Connections and Functions .....	18
Connector .....	18
9.22 Opto Supply .....	19
9.23 Stopping the Hopper.....	19
9.24 Motor Control.....	19
9.25 Coin Counting.....	20
9.26 Coin Payout .....	20
9.27 Coin Dispensing Timing.....	21
<b>10. Electrical Specification</b> .....	<b>23</b>
10.1 External Reset (serial version only) .....	23
10.2 Duty Cycle .....	23
<b>11. Environment</b> .....	<b>24</b>
11.1 General.....	24
11.2 Static.....	24
11.3 Explosive Atmosphere .....	24
11.4 Audible Noise .....	24
11.5 Product Compliance .....	24
11.51 Immunity .....	24
11.52 Safety .....	24
<b>12. Maintenance Schedule</b> .....	<b>25</b>
12.1 Clearing a coin jam:.....	25
<b>13. Serial Compact Hopper 2</b> .....	<b>26</b>
13.1 ccTalk Serial Interface .....	26
13.2 SCH2 v SCH1.....	27
13.3 Address Selection.....	28
13.4 Serial Connector Details .....	29
13.5 Level Sense Connector .....	30
<b>14. Fault Finding and Repair</b> .....	<b>31</b>
<b>15. Appendix 1</b> .....	<b>33</b>
15.1 Baseplate Dimensions .....	33

## Figures:

Figure 1: Standard and Extended Bowl Quick Change Hopper Dimensions .....	10
Figure 2: Standard Bowl Fixed Disk Hopper Dimensions .....	11
Figure 3: High Capacity Bowl Dimensions .....	12
Figure 4: Splashguard Dimensions .....	13
Figure 5: Standard Chute v Universal Chute Dimensions .....	14
Figure 6: Square Bowl and Base (SBB) No Extensions, Hopper Dimensions .....	15
Figure 7: Square Bowl and Base (SBB) + Extensions, Hopper Dimensions .....	16
Figure 8: Parallel Connector .....	18
Figure 9: Motor Supply Switching .....	19
Figure 10: Opto Output Circuit .....	20
Figure 11: Coin Dispense Waveforms .....	21
Figure 12: Compact Hopper ccTalk cct .....	26
Figure 13: Level Sense Connector .....	30
Figure 14: Exploded View .....	32
Figure 15: Baseplate Dimensions .....	33

## Tables:

Table 1: Coin Capacities .....	8
Table 2: Parallel Connector Pin-outs .....	18
Table 3: Coin Payout Rate .....	20
Table 4: Coin Dispense Timings .....	21
Table 5: <b>FIXED DISK</b> Motor Delay Timings (Td) .....	22
Table 6: <b>QUICK CHANGE DISK</b> Motor Delay Timings (Td) .....	22
Table 7: Electrical Specification .....	23
Table 8: Environmental Ranges .....	24
Table 9: Maintenance Schedule .....	25
Table 10: SCH2 v SCH1 (ccTalk commands) .....	27
Table 11: Address Selection .....	28
Table 12: ccTalk Serial Connector pin-out .....	29
Table 13: Fault Finding and repair .....	31

# 1. Diary of Changes

Issue 1.0 - First issue.....	December 2002
Issue 1.1 .....	January 2003
➤	Added <a href="#">Figure 7</a> .
➤	Changed <a href="#">Figure 2</a> title.
➤	Applied TMWP 3.2.
➤	Swapped <a href="#">Figure 5</a> and <a href="#">Figure 6</a> drawings around.
➤	Added Large Black motor delay timings - <a href="#">Table 6</a> .
➤	Added differences between SCH1 and SCH2.
➤	Added <a href="#">Figure 4</a> – Splashguard dimensions.
➤	Added Note to <a href="#">Figure 5</a> .
➤	Added IMPORTANT note to section <a href="#">13</a> .
Issue 1.2 .....	June 2003
➤	Added <a href="#">Figure 3: High Capacity Bowl Dimensions</a>
➤	Added High CB figures to <a href="#">Table 1: Coin Capacities</a>
Issue 1.3 .....	19 <sup>th</sup> August 2003
➤	Changed ccTalk <sup>®</sup> to ccTalk throughout the document.
➤	Added section <a href="#">11.5 Product Compliance</a> .
Issue 1.4 .....	25 <sup>th</sup> November 2003
➤	Added section <a href="#">13.5 Level Sense Connector</a> .
Issue 1.5 .....	June 2004
➤	Changed footer
Issue 1.8 .....	13 <sup>th</sup> Jan 2005
➤	Added <a href="#">Appendix 1 Figure 15: Baseplate Dimensions</a> .
➤	Added section <a href="#">3 Safety Note</a> .
➤	Added <a href="#">Figure 8: Parallel Connector</a> .
Issue 1.9.....	10 <sup>th</sup> Jan 2006
➤	Ammended <a href="#">Table 7</a> fuse ratings
➤	Ammended section <a href="#">3 Safety Note</a> .

## 2. Introduction

The Compact Hopper is a simple single coin denomination payout unit, providing a jam resistant, high speed payout of coins or tokens.

**Compact Hopper**



**Compact Hopper Square  
Bowl and Base (SBB)  
+ 2 Extensions.**



**Compact Hopper Square  
Bowl and Base (SBB).**

### 3. Safety Note

To meet the requirements for EN 60950 the equipment must be installed according to the following requirements:-

- The equipment must be protected by a suitable fuse (see [Table 7](#)).
- The equipment must be supplied from a SELV limited power source.
- The equipment must be installed in an enclosure but positioned so that it is external to any fire enclosure area within the main enclosure.

## 4. Product Overview

A disc, driven when power is applied to the Hopper, rotates and collects coins from a storage bowl. These coins are dispensed from the hopper at a typical rate of 10 coins per second.

The orientation of the motor assembly can be simply altered to allow exit of payout coins from either the side or the rear of the Hopper or the front of the (SBB ONLY).

An optical sensing output is provided to enable host machine counting of output coins. Jam detection is incorporated within the unit to minimise any internal coin jam situations that may occur.

In normal operation it is expected that there are always coins left in the Hopper after any payout. Note, however, that if the Hopper is operated until empty, the last coin may take in excess of 4 seconds to payout, whilst very small coins may not completely empty.

The host machine controls when payout is to commence and cease, and must provide the required drive as detailed in Section [9](#).

**WARNING:**

*Coins may leave the Hopper at a high velocity. Ensure that the coins cannot strike any part of the body and cause injury.*

### 4.1 Operation

Each disc contains a number of holes in which the coins are held in short stacks. The disc is driven by the motor via a gear train. As the disc rotates, the coin at the bottom of one of the stacks will make contact with the ejector fingers and start to push the fingers back. Further rotation of the disc will cause the coin to start to move outwards into the exit slot. At this point the spring will be free to pull the ejector fingers forward and push the coin through the exit slot.

An optical detector is formed by an LED transmitter and photodetector on the PCB. The infra-red light beam is routed across the exit slot via a light guide. When a coin passes through the exit, the light beam will be broken and a coin output signal will be generated.

There are a range of discs, ejector fingers and adjuster plates available to provide optimum performance for coins within the specified range.

### 4.2 Coin Routing

Coins are entered into the Hopper through the top of the bowl, and exit through the side or the rear or the front (SBB ONLY) of the Hopper as shown in [Figure 1](#) and [Figure 6](#).

## 5. Mechanical Features

### 5.1 Hopper Dimensions

The hoppers overall dimensions, mounting arrangement, coin entry and exit points are detailed in [Figure 1](#) and Figure 6. Note that, when used in the side exit mode, the rear of the motor protrudes from the rear of the casing, within the overall dimensions of the hopper envelope.

### 5.2 Hopper Weight

Compact Hopper (Std) = 570 g – empty  
 Compact Hopper (SBB no extensions) = 616 g – empty  
 SBB Extension = 102 g – empty

### 5.3 Coin Size Range

Hoppers can be configured to pay out coins in the diameter range 16.25 – 31.00mm, and within the thickness range 1.25 - 3.20mm. However, each coin needs to be qualified on an individual coin basis.

*For further information on qualification of coins, please contact Money Controls Technical Services Department on +44 (0)161 955 0124.*

### 5.4 Coin Capacity

The coin capacity of the hopper is between 200 and 1000 depending on their physical size, the type of bowl used and the number of extensions.

*Table 1: Coin Capacities*

Coin	Diameter (mm)	Thickness (mm)	Standard bowl	Extended bowl	High Capacity Bowl	Square Bowl and base +x extensions			
						0	1	2	3*
£2	28.40	2.50	189	252	500	252	442	631	820
£1	22.50	3.10	235	314	650	314	549	785	1020
50p new	27.30	1.80	282	376	760	376	659	941	1223
20p	21.40	1.80	459	613	1250	613	1072	1531	1991
10p	24.50	1.83	349	465	930	465	814	1163	1512
5p	18.00	1.73	679	905	1800	905	1584	2262	2941
2p	25.90	1.80	316	421	850	421	652	932	1212
1p	20.25	1.43	652	870	1750	870	1522	2174	2826

**Note: these capacities are subject to a +/- 10% error.**

**\*WARNING:- 3 Extensions is the maximum allowed and may not be suitable for all coins mentioned above. Please check with Money Controls Technical Services Department.**



## 6. Electrical Features

Circuitry within the Hopper permits control of coin payout and provides a digital signal representative of the presence of a coin at the exit window.

Output coins are sensed as they obscure an infra red light path between an emitter and a light guide leading to a photo transistor at the exit.

The Hopper will automatically brake when placed in the off state by the Host machine, thus preventing overrun and excessive coin payout.

An overcurrent detection circuit reverses the Hopper momentarily in the event of a coin jam, and then attempts to continue payout. This oscillation of the disc will continue until either the coins are freed, the Hopper is switched off, or the overload trip switches.

Should the latter occur the Hopper supply must be disconnected, the fault condition must be corrected and the trip be allowed time to cool (approx. 30 secs) before the hopper will restart.

## 7. Overall Dimensions

Figure 1: Standard and Extended Bowl Quick Change Hopper Dimensions

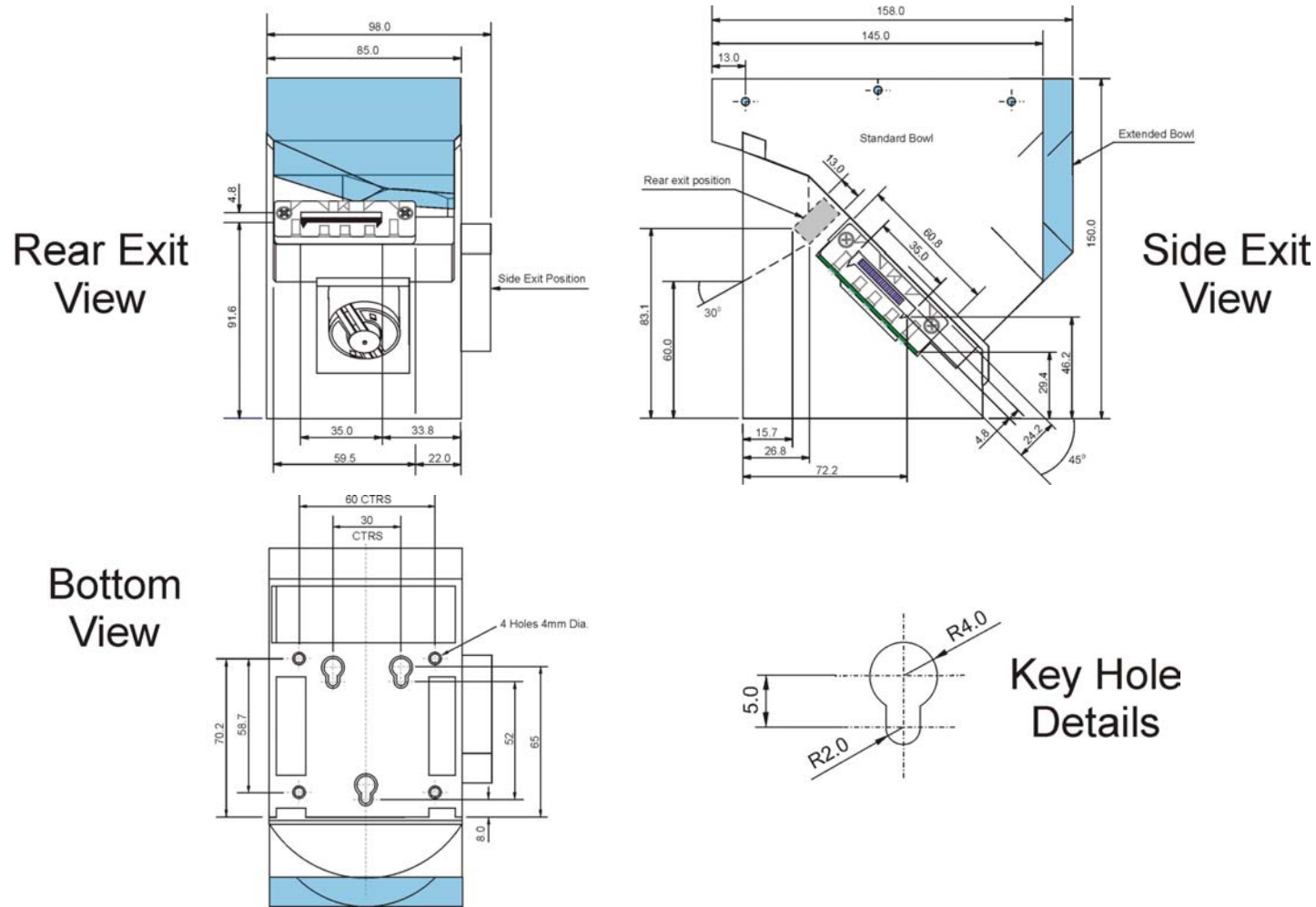
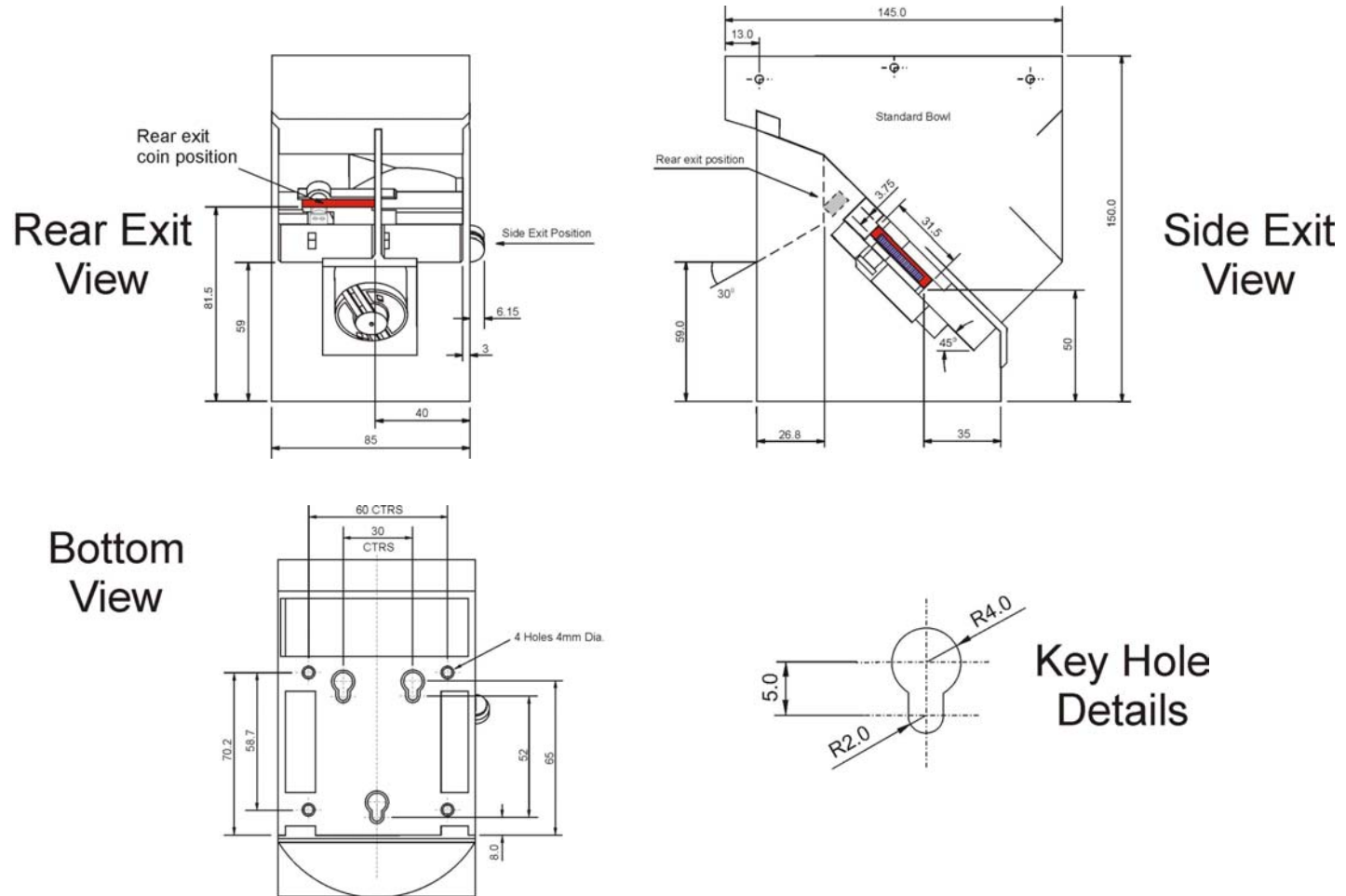
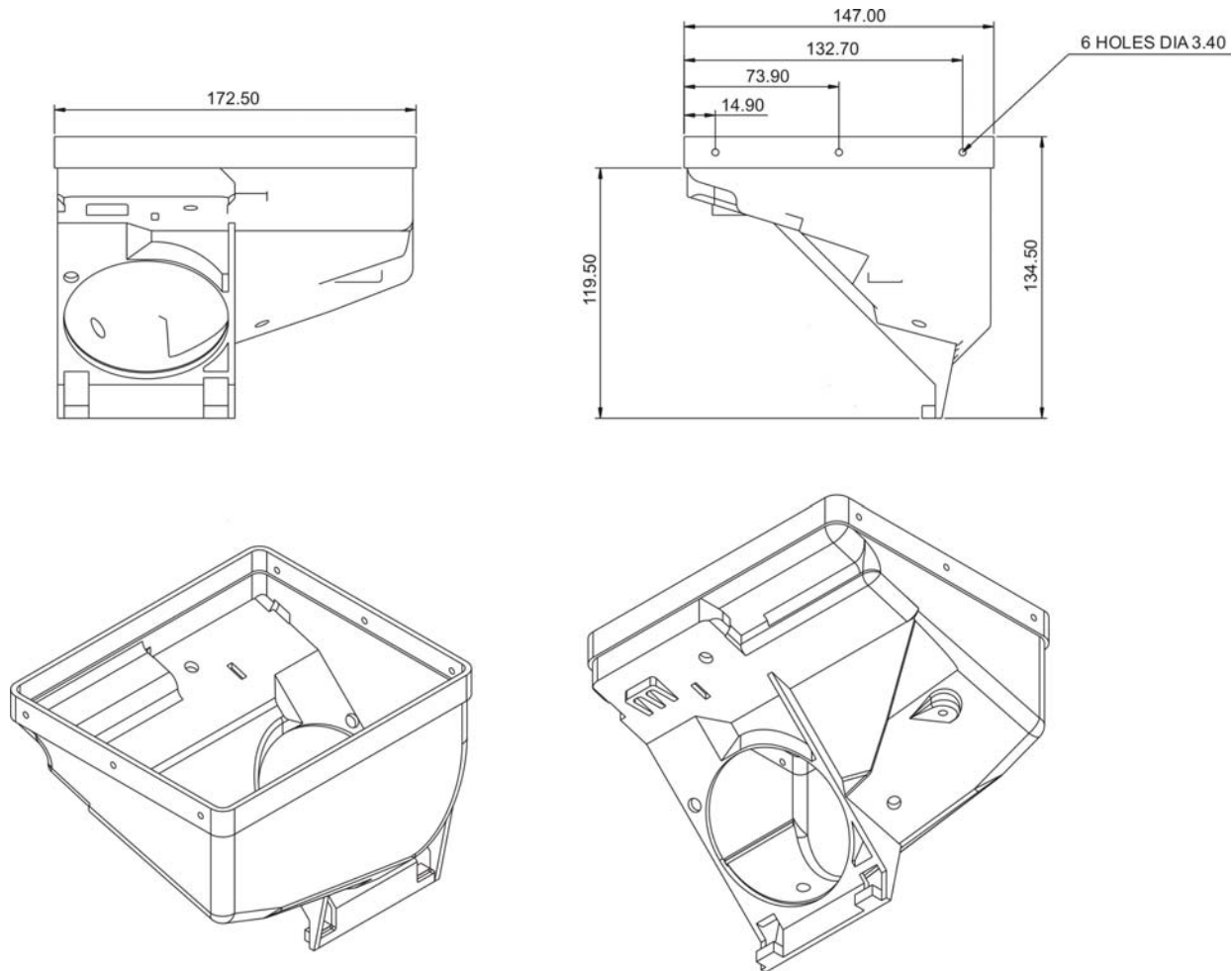

Figure 2: Standard Bowl Fixed Disk Hopper Dimensions



### 7.1 High Capacity Bowl

Figure 3: High Capacity Bowl Dimensions



## 7.2 Splashguard.

The 'splashguard' was developed to stop coins from jumping out of the hopper bowl, when the standard bowl was almost full, room permitting. It was NOT developed as an extension to the standard bowl and Money Controls do not recommend its use as such.

*Figure 4: Splashguard Dimensions*

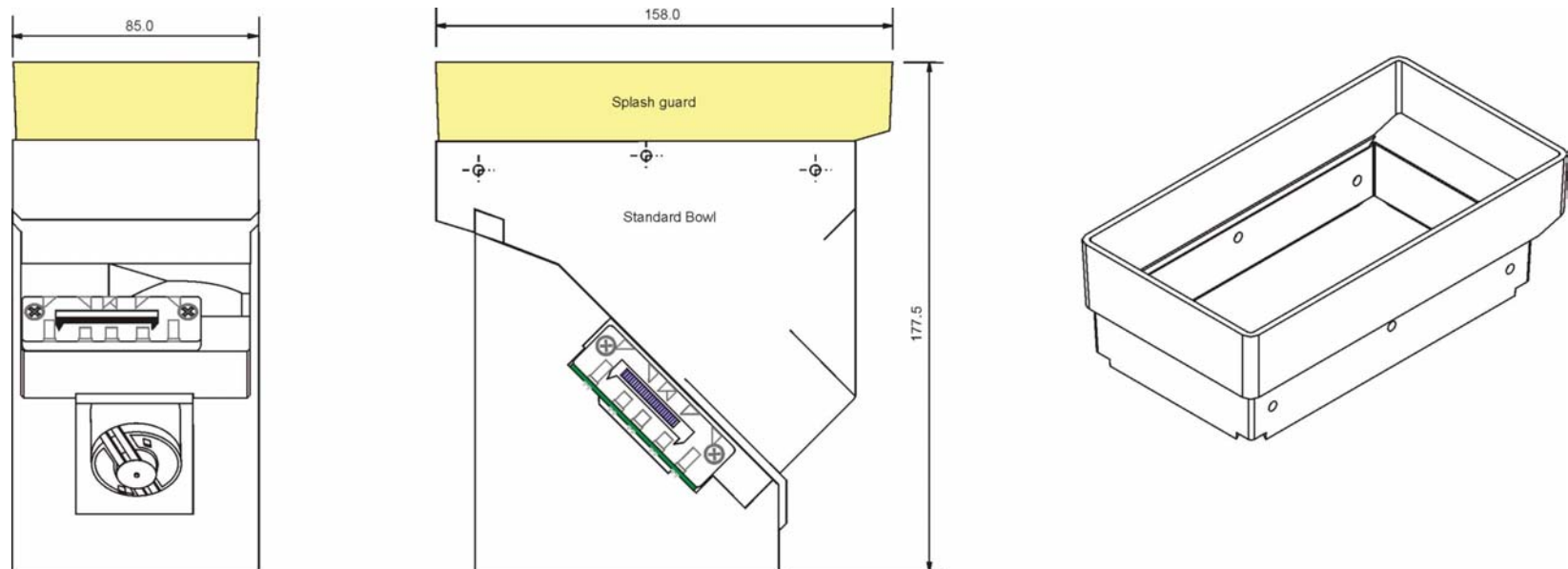

### 7.3 Rear Exit Chutes.

**NB – THE FOLLOWING OPTION PERMUTATIONS ARE NOT CURRENTLY AVAILABLE:**

- Q.C.D. / Light Guide + Rear Exit + Extended Bowl.
- Q.C.D. / Light Guide + Rear Exit + Extended Bowl + Chute.
- Q.C.D. / Light Guide + Rear Exit + Standard Bowl + STD Chute for coins over 26mm in diameter & 2.10 thick

Figure 5: Standard Chute v Universal Chute Dimensions

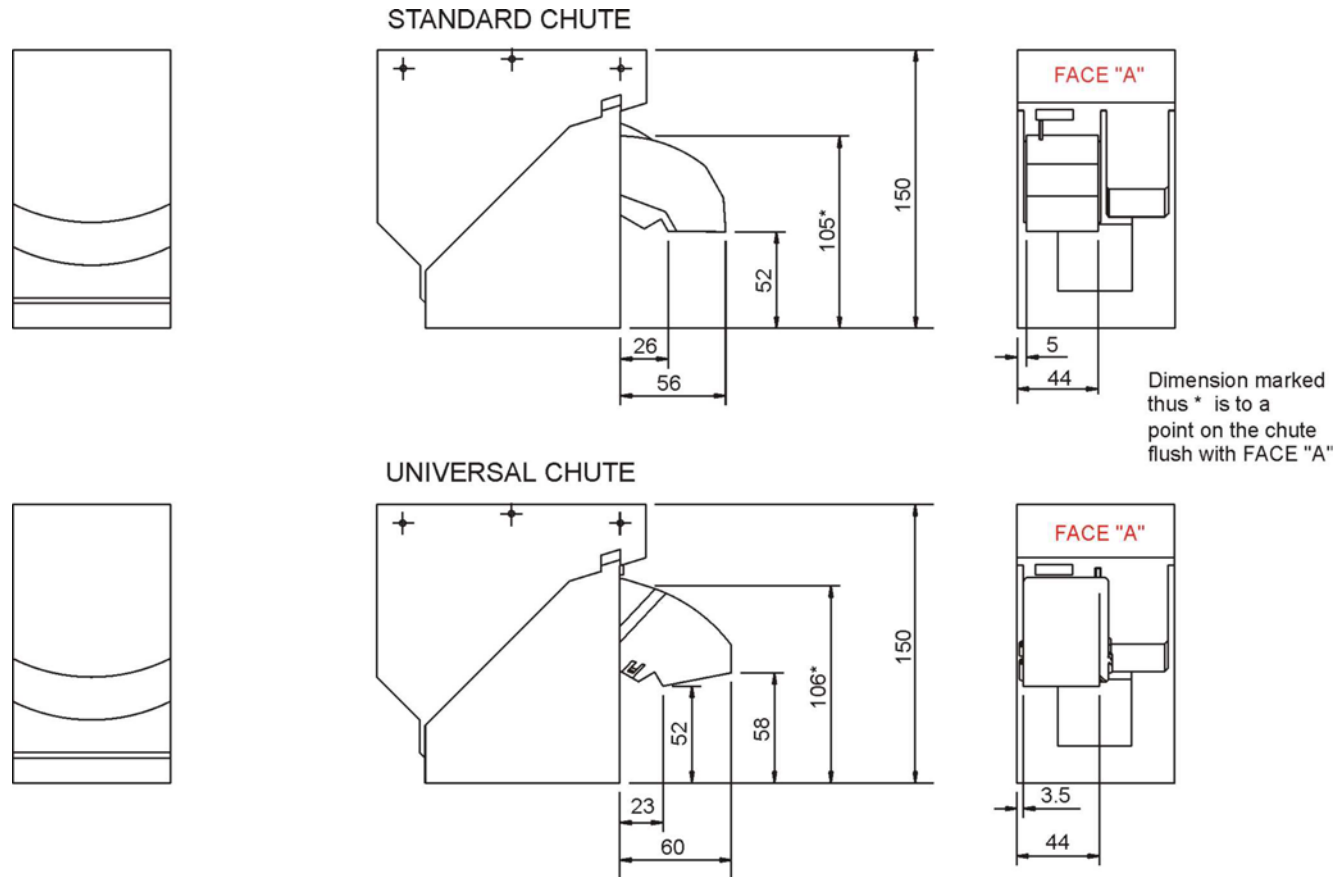

Figure 6: Square Bowl and Base (SBB) No Extensions, Hopper Dimensions

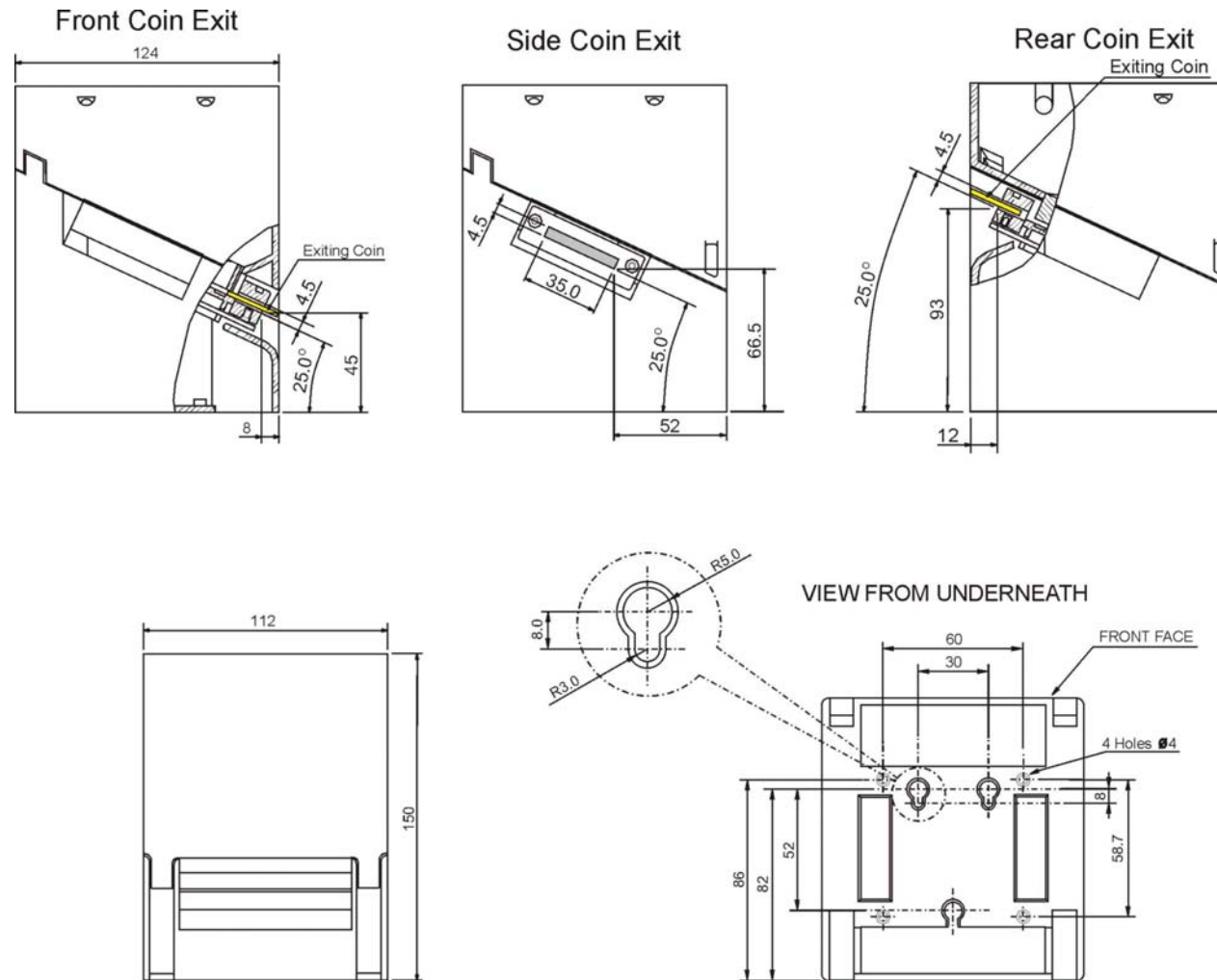
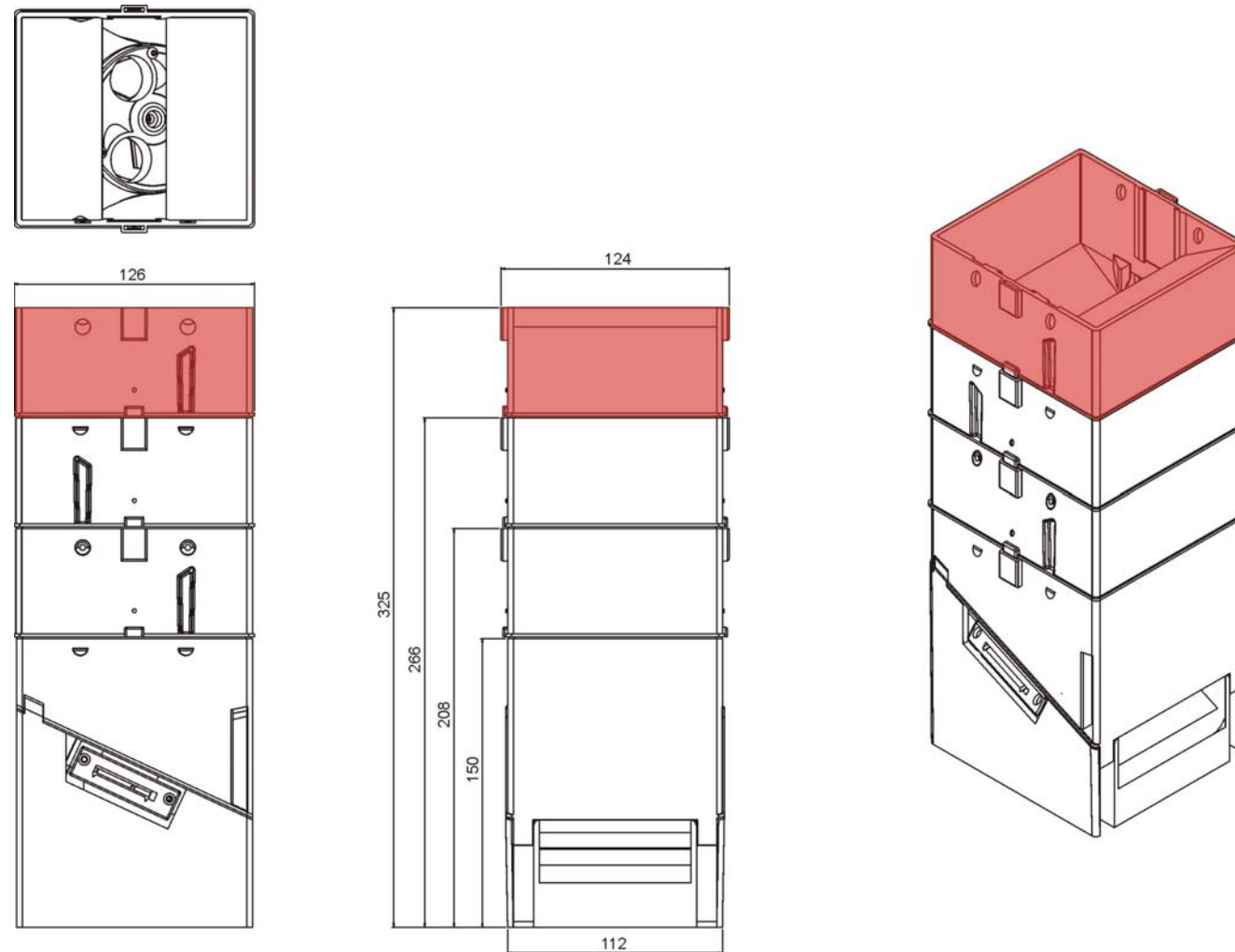

Figure 7: Square Bowl and Base (SBB) + Extensions, Hopper Dimensions



**WARNING: Before using 3 extensions, please call Money Controls Technical Services department on +44 (0)161 955 0124.**



## 8. Installation and Removal

**Warning: Ensure that the power has been disconnected from the hopper before removal.**

### 8.1 Dismantling the hopper

- Gently pull out the securing clips on the back of the base.
- Tilt the bowl forward until it is clear of the clips.
- Slide the bowl forward until the locating lugs, at the front of the bowl, are clear of the slots in the base.
- Lift the motor assembly out of the base.
- Disconnect the cable (if fitted) from the motor assembly.

### 8.2 Securing the hopper base

Two sets of fixing holes have been provided in the base to allow the Hopper to be secured in a host machine – 4 x 4mm holes, and 3 keyholes. See [Figure 1](#) or Figure 6 for positions of the hole centres.

#### 8.21 USING THE 4MM HOLES

- Dismantle the hopper. (see section [8.1](#))
- Drill 4 holes on the centres as shown in [Figure 1](#) or Figure 6
- Place base over holes and fix into position using M3 screws.

#### 8.22 USING THE KEYHOLES

- Dismantle the hopper
- Drill 3 holes in the centres as shown in [Figure 1](#) or Figure 6
- Insert 3 x M3.5 screws. DO NOT tighten
- Place base over the back and push far back as possible
- Tighten the screws to fit the base in position

**NOTE: Studs may be used in place of two of the screws.**

After the base has been secured, the Hopper should be re-assembled as described in section [8.3](#).

### 8.3 Hopper Assembly

- Connect the cable to the motor assembly, ensuring that it is the correct way round.
- Lower the motor assembly into the base, ensuring that the coin exit is in the desired position (side or rear [or front SBB ONLY]).
- Re-connect the level sense loom, if fitted.
- Locate the lugs, on the front of the bowl, into the slots at the front of the base.
- Gently press down on the top of the bowl until the securing clips, on the base, click into the slots on the bowl.

### 8.4 Coin Spillage

With some coin types a coin can occasionally jump upwards out of the bowl. If this is likely to be a problem the user may wish to fit his own version of the coin entry chute or baffle which is most suited to the application.

## 9. Electrical Interface

Failure to observe the interface requirements specified in this document may result in erroneous counts, incorrect payout rate, damage to the Hopper or cause unacceptable voltage drops affecting other units dependent upon that supply.

The supply wiring to the Hopper should be of sufficient current rating and run as a twisted pair (+24V and 0V) over a maximum length of 3 metres.

### 9.1 Interface Options

Interfacing is standard across all the *parallel* coinage variants of the Compact Hopper.

### 9.2 Interface Connections and Functions

#### 9.21 CONNECTOR

*Figure 8: Parallel Connector*

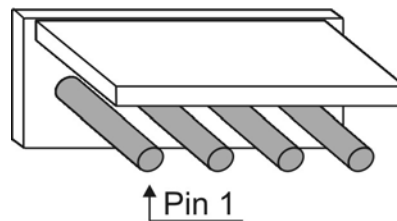

*Table 2: Parallel Connector Pin-outs*

Pin	Function
1	12V / 24V DC positive supply and motor control.
2	0V common supply.
3	Opto supply.
4	Coin count output.

The on board 'wall polarised' plug requires a 0.2" (5.08mm) pitch connector, MOLEX 3001 series 4 way crimp terminal housing or equivalent.

## 9.22 OPTO SUPPLY

The optical sensor can be powered separately from the motor by connecting the positive supply to Pin 3. This will ensure that the coin count output remains at 0V when the motor supply is turned off. It is also possible to test that the optical sensor is operating correctly prior to turning on the motor. This is achieved by:

- i) Ensuring motor supply (Pin 1) is turned off and opto supply (Pin 3) is on.
- ii) Check that coin count output (Pin 4) is at 0V.
- iii) Turn off opto supply.
- iv) Check that coin count output switches to +V.
- v) Turn on opto supply again.
- vi) Check that coin count output returns to 0V.

## 9.23 STOPPING THE HOPPER

When the required number of coins (low to high transitions) have been detected at the exit output, the positive supply must be removed, thus stopping the hopper motor and applying the internal brake. If the power supply is not removed within the time specified in [Table 5](#) and [Table 6](#), additional coins may be paid out.

## 9.24 MOTOR CONTROL

The motor is controlled simply by the application and interruption of the positive supply. The motor is automatically braked when the supply is disconnected.

When the positive supply is applied to pin 1 the Hopper motor will start to turn, and provided the bowl contains coins, payout will commence.

When the supply is interrupted to stop the Hopper, it is essential that no capacitance exists between the 0V and the supply input to the Hopper.

If a capacitance greater than 0.1  $\mu\text{F}$  is present the Hopper will be unable to brake efficiently, giving the potential for an excessive coin payout. (i.e. Hopper over-run).

*Figure 9: Motor Supply Switching*

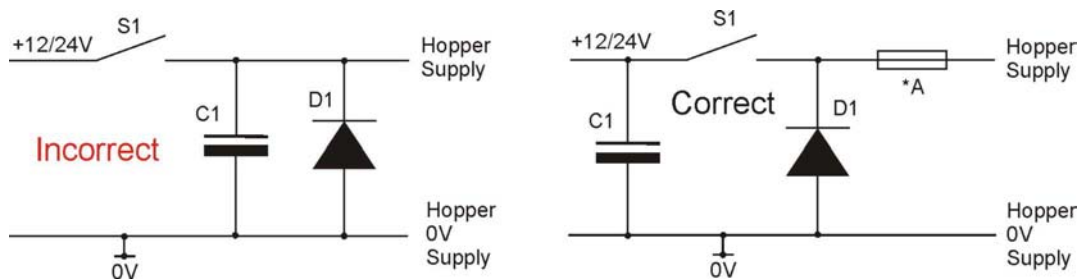

**NOTE:** *Switch S1 should be a suitable semiconductor device or relay contact.*

**D1 is required if a semiconductor is used as Switch 1.**

**If a relay is used for Switch 1, the contacts should be appropriately protected for the inductive load of the Hopper motor.**

**The rating of Switch 1 should be sufficient to handle the load requirements of the Hopper. See [Table 7](#).**

**9.25 COIN COUNTING**

The coin count output on pin 4, is an open collector NPN transistor which acts like a switch. This output should have a pull-up resistor connected to it, as shown in [Figure 9](#).

When the exit slot is clear, i.e. no coin is being dispensed the transistor is switched on and the output signal is connected to 0V. As a coin is paid out it will block the optical sensor and the transistor will turn off. This will cause the output signal to be pulled up to the +V voltage in the host machine. The transistor will remain off until the coin has cleared the exit, as shown in [Figure 10](#).

The output transistor will be turned off when power is removed from the Hopper. This condition should not be interpreted by the host as a coin count signal. See [Figure 10](#).

It is recommended that the count output signal is debounced by the host machine to ensure that any short pulses, which may appear during power on or power off, are ignored. See section [9.27](#) for timing details.

*Figure 10: Opto Output Circuit*

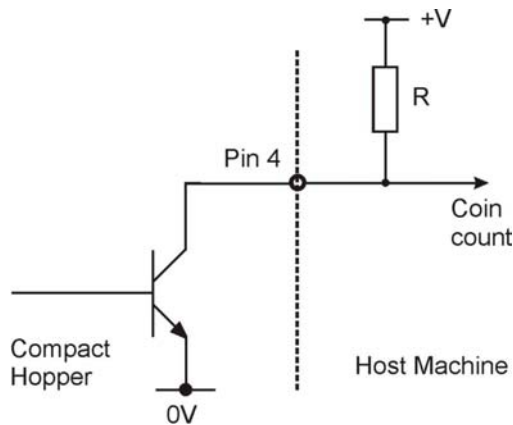

Maximum +V voltage	30Vdc
Maximum current	30 mA
“No coin” voltage (transistor is on)	0.5V max

**9.26 COIN PAYOUT**

*Table 3: Coin Payout Rate*

Mode	Rate
Multi coin payout	8 - 10 coins per second approx.
Single coin payout	2 coins per second approx.

## 9.27 COIN DISPENSING TIMING

Figure 11: Coin Dispense Waveforms

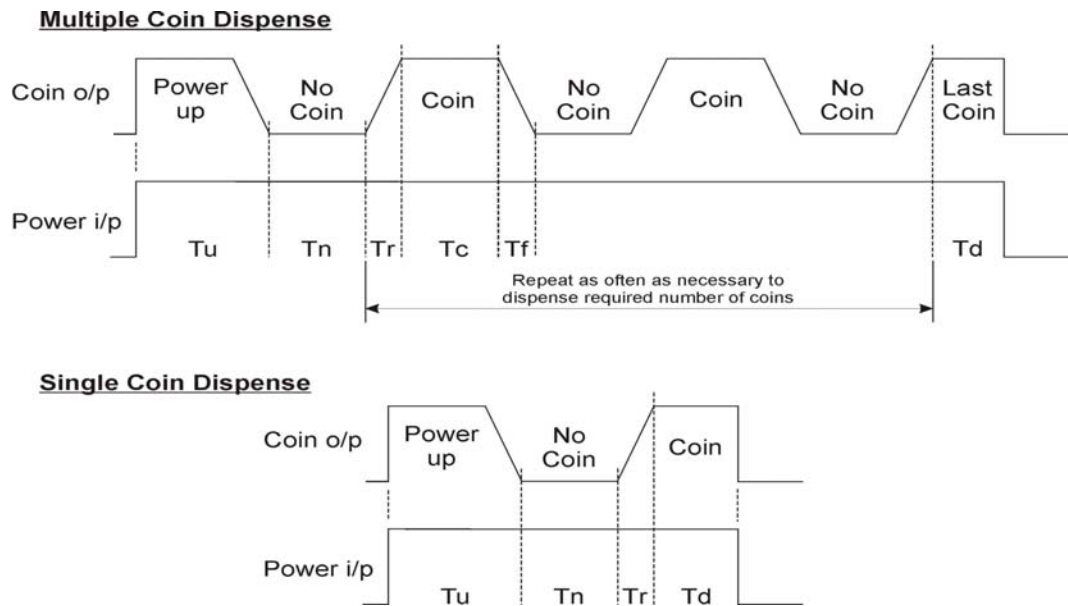

Table 4: Coin Dispense Timings

Symbol	Description	Min	Max
Tu	Time from application of power to the output signal being valid.	-	3ms
Tr	Recommended debounce time on rising edge of output signal.	1ms	2ms
Tf	Recommended debounce time on falling edge of output signal.	1ms	10ms
Tc	Time during which a coin is present in the opto-detector i.e. coin present signal	5ms	-
Tn	Time when a coin is not present in the opto detector	25ms	-
Td	See Motor Delay Timings – see <a href="#">Table 5</a> and <a href="#">Table 6</a>	-	-

**Table 5: FIXED DISK Motor Delay Timings (Td)**

<b>Disc</b>	<b>Min (ms)</b>	<b>Max (ms)</b>
Grey	0	10
Black	0	10
Brown	0	10
Blue	0	10
Green	10	20
Purple	10	20
Red	22.5	27.5
Orange	22.5	27.5

**Table 6: QUICK CHANGE DISK Motor Delay Timings (Td)**

<b>Disc</b>	<b>Min (ms)</b>	<b>Max (ms)</b>
Grey	0	10
Black	0	10
Green	0	10
Blue	10	20
Yellow	22.5	27.5
Brown	22.5	27.5
Purple	22.5	27.5
Red	22.5	27.5
Orange	22.5	27.5
Fresh Orange	22.5	27.5
Large Black	22.5	27.5

## 10. Electrical Specification

**MCL recommend a 24V, 4A (12V, 5A) power supply.**

*Table 7: Electrical Specification*

Electrical Specification	12V version	24V version
Supply Voltage	+12V	+24V
Absolute Maximum	+14V	+26V
Minimum	+10V	+19V
Ripple	± 1.0V	± 2.0V
Typical Operating Current/No Load	0.5A	0.35A
Typical Operating Current/Max Load	1.1A	0.9A
Surge Current/Start Up and Reverse #	4.5A	3.6A
Opto supply current	25mA	25mA
The supply must be able to maintain V within the above limits while switching from no load to delivering *A into a non-inductive load.	*5A	*4A
Fuse size (anti-surge / delay). See <a href="#">Figure 9</a>	4A	3A

**Warning:- The Hopper must not be operated outside these limits.**

# Motor start up and reversing surge current may reach 5000mA for 5ms falling to 3000mA for 30ms before settling to consumption as defined above after 200ms.

### 10.1 External Reset (serial version only)

Signal, active low with 10K pull up to +5V

Input volts (low)	0.6V max
Input volts (High)	3.5V min (5.0V max)

### 10.2 Duty Cycle

The Hopper is designed from intermittent operation only and must not be permitted to run continuously for longer than 30 Seconds.

ON/OFF ration: 1 : 1

The ON period must average no more than the previous OFF time. Failure of the host machine to limit the ON time can result in overheating and degradation of the motor.

## 11. Environment

*Table 8: Environmental Ranges*

Operating Temperature	0 to +50 <sup>0</sup> C
Storage Temperature	-20 to +70 <sup>0</sup> C
Operating Humidity	10 to 85% RH non condensing
Storage Humidity	5 to 95% RH non condensing

### 11.1 General

**Do not permit bright light or infrared radiation to fall on the exit window area.**

Ensure coins can always move freely away from the exit.

### 11.2 Static

It is possible for coins paid out by the Hopper to have a static charge on them. It is desirable that coins are discharged to earth before being presented to the user.

### 11.3 Explosive Atmosphere

The Hopper should not be operated in an explosive atmosphere.

### 11.4 Audible Noise

Audible noise generated by an empty Hopper is typically 80-85 dB's.

**NOTE: Noise measurement taken at a distance of 1m from the Hopper.**

### 11.5 Product Compliance

#### 11.51 IMMUNITY

This product is compliant with EMC test specification EN50082-1; 1997

#### 11.52 SAFETY

This product is compliant with EN60950; 1992 + Amdt A1 & A2: 1993 & A3: 1995 Safety. See section [3](#) for further information.



## 12. Maintenance Schedule

**WARNING:**

**Coin dust may accumulate in the Hopper during use. Inhalation of the dust should be avoided during maintenance operation. Ensure that power has been removed from the Hopper before any maintenance operations are performed.**

Table 9: Maintenance Schedule

Maintenance Schedule	
Every 50,000 to 100,000 depending on coin type.	Using a mild detergent on a damp cloth, clean the light guide. <b>No spray solvents should be used.</b>
Every 500,000 coins.	Replace ejector fingers and spring
Every 1,000,000 coins.	Replace adjuster plate
Expected product lifetime:	3 million coins with routine maintenance

### 12.1 Clearing a coin jam:

- Remove all coins from bowl.
- Remove motor assembly from base as described in section [8.1](#).
- Clear the jammed coin by either:
  - i. Rotating the disk manually, first anti-clockwise then clockwise to free the coin  
OR
  - ii. Push the coin back in using another coin.

**Note: A common cause is damaged or bent coins. Do not put these coins back into the bowl.**

- Remove any debris from the disk bed assembly.
- Clean the exit window opto with a clean dry cloth.
- Re-assemble, as described section [8.3](#).
- Refill and test the hopper.

## 13. Serial Compact Hopper 2

The Serial Compact Hopper MK2 (SCH2) is a serially controlled version of the Compact Hopper.

Rather than using the parallel interface of the standard Compact Hopper, the SCH2 uses a serial interface called “ccTalk”.

The SCH2 has improved security features (see below) as well as the ability to “daisy chain” multiple devices to the same wiring bus. It is also possible with SCH2 to integrate other Money Transaction devices such as coin, note or card acceptors.

*If you already have a machine interface for the Mk1 version of the Serial Compact Hopper then the following information may be of interest:-*

The following changes have been made on the Mk2 version...

- Serial connector has 2 extra pins at the end - pins 1 to 8 are the same
- The ‘Dispense hopper coins’ command is radically different - it requires an 8 byte crypto code and returns the new event counter rather than an ACK
- The ‘Test hopper’ command now returns 2 bytes of flags rather than 1 byte
- The ‘Modify variable set’ command takes an extra byte
- Various product identification strings have changed

**Note: For cctalk protocol information, please contact Money Controls Technical Services Department on +44 (0)161 955 0124.**

**IMPORTANT:** For security reasons the ccTalk data for the SCH2 is **ENCRYPTED**. Please contact Money Controls Technical Services Department on +44 (0)161 955 0124 for further information. [An UNENCRYPTED version is now available...](#)

### 13.1 ccTalk Serial Interface

This is the ccTalk electronic interface circuit on the SCH2.

There are many options for the host interface circuit but we recommend an open collector drive.

*Figure 12: Compact Hopper ccTalk cct*

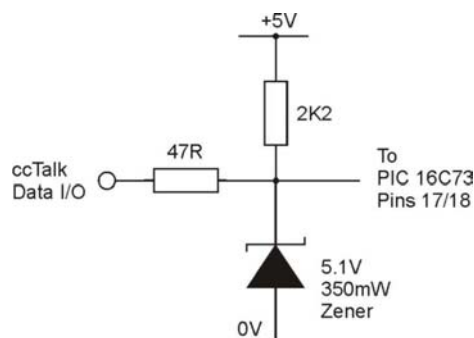

## 13.2 SCH2 v SCH1

This is the command set difference between Mk2 and Mk1...

*Table 10: SCH2 v SCH1 (ccTalk commands)*

cctalk Command	Supported on Mk2 ?	Supported on Mk1 ?
Header 254 : Simple poll	Y	Y
Header 253 : Address poll	Y	Y
Header 252 : Address clash	Y	Y
Header 251 : Address change	Y	Y
Header 250 : Address random	Y	Y
Header 247 : Request variable set	Y	Y
Header 246 : Request manufacturer id	Y	Y
Header 245 : Request equipment category id	Y	Y
Header 244 : Request product code	Y	Y
Header 242 : Request serial number	Y	Y
Header 241 : Request software revision	Y	Y
Header 236 : Read opto states	Y	Y
Header 219 : Enter new PIN number	Y	N
Header 218 : Enter PIN number	Y	N
Header 217 : Request payout high / low status	Y	Y
Header 216 : Request data storage availability	Y	Y
Header 215 : Read data block	Y	N
Header 214 : Write data block	Y	N
Header 192 : Request build code	Y	Y
Header 172 : Emergency stop	Y	Y
Header 171 : Request hopper coin	Y	Y
Header 169 : Request address mode	Y	Y
Header 168 : Request hopper dispense count	Y	Y
Header 167 : Dispense hopper coins	Note $\alpha$	Y
Header 166 : Request hopper status	Y	Y
Header 165 : Modify variable set	Note $\alpha$	Y
Header 164 : Enable hopper	Y	Y
Header 163 : Test hopper	Note $\alpha$	Y
Header 161 : Pump RNG - new header	Y	N
Header 160 : Request cipher key - new header	Y	N
Header 004 : Request comms revision	Y	Y
Header 003 : Clear comms status variables	Y	Y
Header 002 : Request comms status variables	Y	Y
Header 001 : Reset device	Y	Y

Note  $\alpha$  : The data packets have been modified on these commands

### 13.3 Address Selection

The default ccTalk bus address for a 'payout' device is 3. This is the address of the Serial Compact Hopper if no connections are made to the address select pins (pins 1 to 3) on the connector.

*Table 11: Address Selection*

Address Select 3	Address Select 2	Address Select 1	Serial Address
			3
		X	4
	X		5
	X	X	6
X			7
X		X	8
X	X		9
X	X	X	10

**X = Connect to +Vs**

For applications requiring more than one hopper on the serial bus, one or more of the address select lines may be connected to +Vs. A total of 8 unique bus address may be generated in this way, in the range 3 to 10 inclusive.

A number of mating connections on a multi drop bus cable may be wired uniquely to allow operation of multiple hoppers. Since address selection is done externally, any Serial Compact Hopper may be plugged into any position on the bus and the host machine will know which one is paying out a particular coin. Address determination from the connector is only done at power up or reset. Changing the address select lines afterwards has no effect.

### 13.4 Serial Connector Details

The SCH2 uses ccTalk interface with a 10 pin connector with the pinouts as follows:-

PCB Connector.

2.54mm (0.1-inch) pitch 10 way with locking wall.

Part number: Molex 22-27-2101 or equivalent

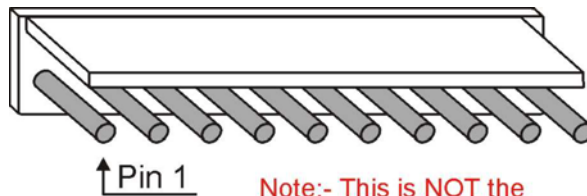

Note:- This is NOT the conventional position of pin 1.

Serial Connector Pinout:-

Operation can be achieved with just 3 wires.

+24 V to pin 4.

GND to pin 6.

Bi-directional serial data line to pin 8.

Pins 4 and 5, and pins 6 and 7 are linked internally. The provision of extra pins is to simplify the manufacture of a multi-drop cable using thicker wire for the power leads. There can be a 'power in' and a 'power out' pin, and the hoppers can be 'daisy chained'.

*Table 12: ccTalk Serial Connector pin-out*

Pin	Function
1	Address Select 3 – MSB
2	Address Select 2
3	Address Select 1 – LSB
4	+ V s
5	+ V s
6	0V
7	0V
8	/DATA (ccTalk)
9	N/C
10	/RESET

ccTalk parameters:

Remember to configure the baud rate to 9600. **The hopper can only operate at 9600 baud.**

**Note: Refer to the latest issue of the 'ccTalk Serial Communication Protocol/Generic Specification' for an explanation of the protocol and it's implementation on any platform.**

## 13.5 Level Sense Connector

Figure 13: Level Sense Connector

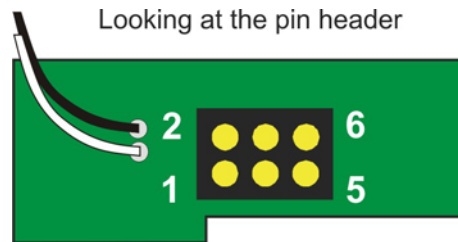

Pin	Function
1	High Level Plate
3	Low Level Plate
5	Plate Common
2	High Level Link
4	Low Level Link
6	Link Common

### Operation

To notify the hopper software that level plate sensors are fitted, the link pins should be connected as follows...

Mode	Connections
High level plates only	pin 2 to pin 4
Low level plates only	pin 4 to pin 6
High & low level plates	pin 2 to pin 4 to pin 6

Otherwise, no connections should be made.

The level plates themselves should be connected through the corresponding plate pin ( pin 1 for high level, pin 3 for low level ) and the plate common ( pin 5 ).

## 14. Fault Finding and Repair

General purpose test equipment (Meter etc) is all that is required for on-site diagnosis of Compact Hopper fails.

*Table 13: Fault Finding and repair.*

<b>Problem:</b>	<b>Check:</b>	<b>Cure:</b>
Coins fail to unjam:	Ensure coin exit is clear.	Remove blockage from coin exit.
	Ensure correct coins in hopper.	Fill hopper with correct coins.
	Ensure no badly bent coins in hopper.	Remove bent coin/s.
Motor fails to run:	Supply fuse.	Replace fuse.
	Protection device tripped.	Wait 30 seconds with supply OFF.
	Hopper has detected an opto fault.	#Check EEPROM flags.
Over payout of coins:	Check opto area/coin exit area for dirt.	Clean opto/coin exit area.
Under Payout Of Coins:	Check opto area/coin exit area for dirt.	Clean opto/coin exit area.
	Ensure hopper contains sufficient coins.	Refill hopper.

#Serial version only.

Figure 14: Exploded View

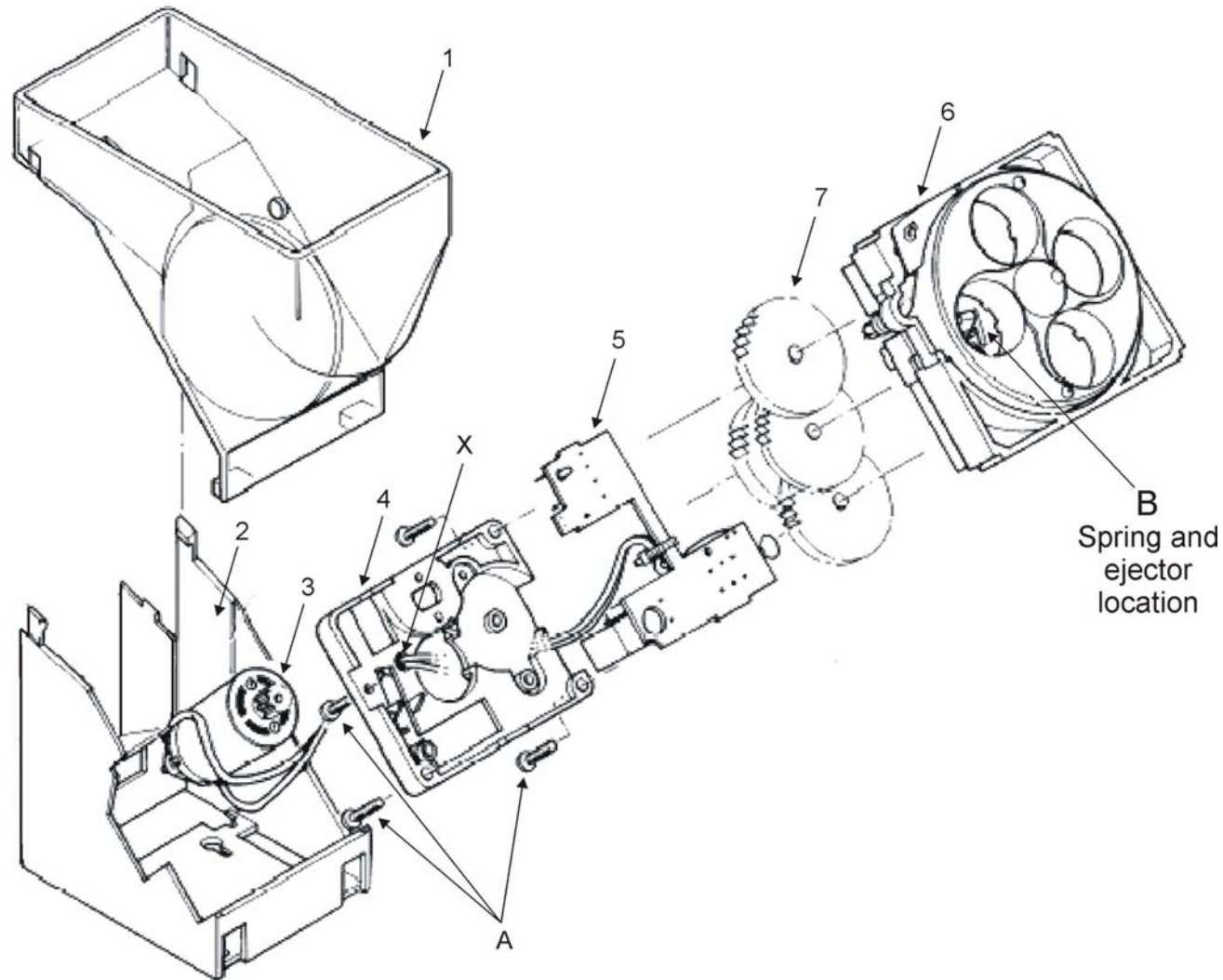

### Parts List

1. Bowl
2. Base
3. Motor assembly
4. Gearbox cover
5. P.C.B. assembly
6. Disk bed assembly  
(state coinage)
7. Gear cluster  
(not a serviceable part -  
shown for reference only).

*Note: When ordering motor assembly, gearbox cover, PCB assembly or disc bed assembly, screws are supplied separately. The parts listed are the only user serviceable components available. All units requiring additional work should be returned to a Money Controls group company or approved service centre. Tampering will invalidate the warranty.*



# 15. Appendix 1

## 15.1 Baseplate Dimensions

Figure 15: Baseplate Dimensions

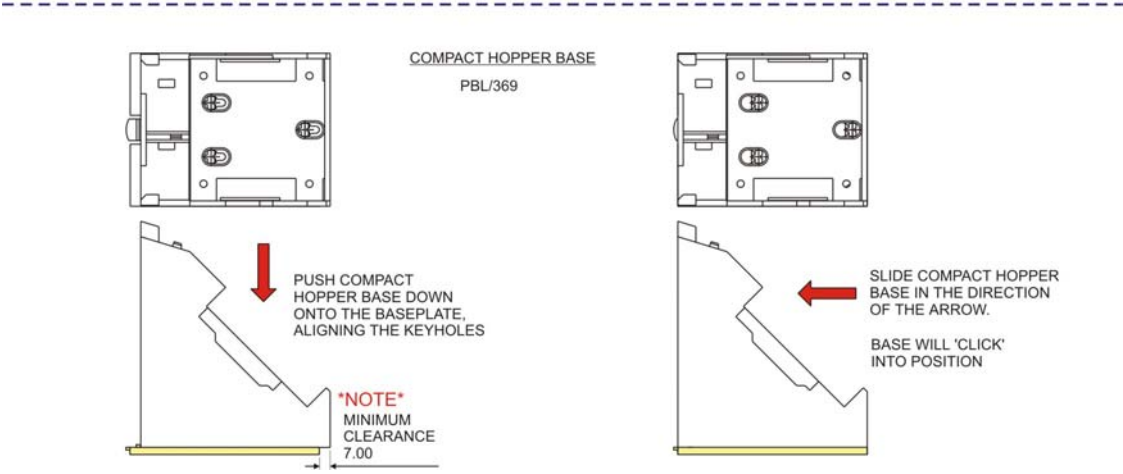
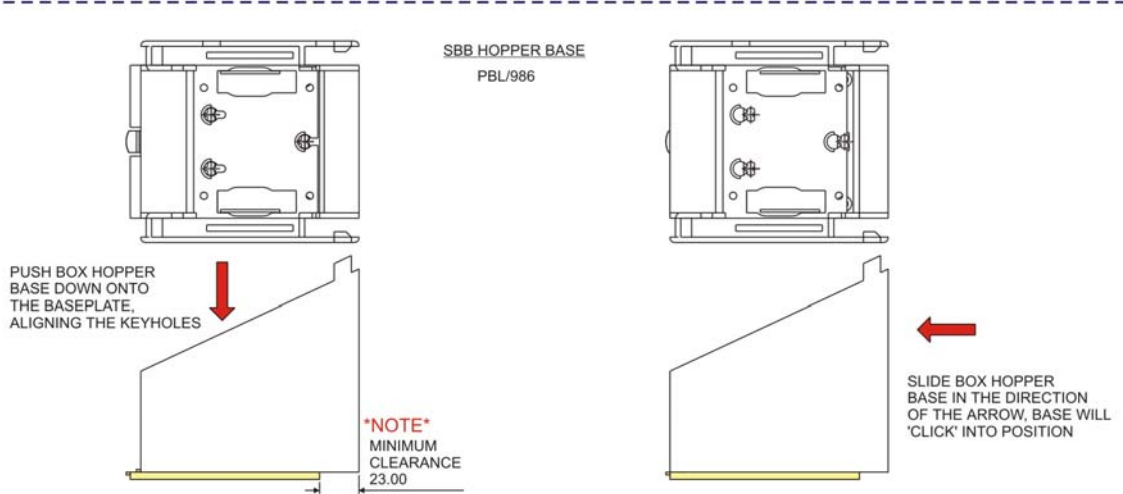
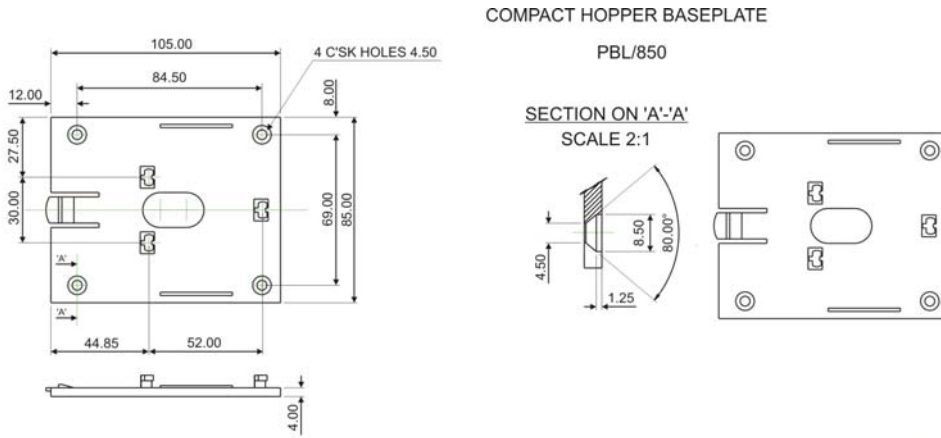

This manual is intended only to assist the reader in the use of this product and therefore Money Controls shall not be liable for any loss or damage whatsoever arising from the use of any information or particulars in, or any incorrect use of the product. Money Controls reserve the right to change product specifications on any item without prior notice.