

# MCL PCI Card Technical Manual



This document is the copyright of Money Controls Ltd and may not be reproduced in part or in total by any means, electronic or otherwise, without the written permission of Money Controls Ltd. Money Controls Ltd does not accept liability for any errors or omissions contained within this document. Money Controls Ltd shall not incur any penalties arising out of the adherence to, interpretation of, or reliance on, this standard. Money Controls Ltd will provide full support for this product when used as described within this document. Use in applications not covered or outside the scope of this document may not be supported. Money Controls Ltd. reserves the right to amend, improve or change the product referred to within this document or the document itself at any time.

## Contents

<b>1. Diary of changes.....</b>	<b>4</b>
<b>2. Introduction.....</b>	<b>5</b>
<b>3. Outline Specification.....</b>	<b>6</b>
3.1 Functional Block Diagram.....	6
3.2 Annotated Picture.....	7
3.3 Feature Description.....	7
<b>4. Operation.....</b>	<b>9</b>
4.1 Hardware Installation.....	9
4.2 Software Installation (under XP).....	11
4.3 Software Development.....	13
<b>5. CcTalkConnections.....</b>	<b>14</b>
5.1 PCI ccTalk Connector.....	14
5.2 Lumina / SR5.....	14
5.3 SR3/Condor Plus.....	15
5.4 Serial Compact Hopper 2.....	15
5.5 Serial Universal Hopper.....	16
<b>6. Input / Output Connectors.....</b>	<b>17</b>
6.1 Switches.....	17
<b>7. Meter Connector.....</b>	<b>18</b>
7.1 Meter Connector.....	18
7.2 MC2600 / RJ-45 Connector.....	18
7.3 Ardac 5 Connector.....	19
<b>8. Electrical Interface Requirements.....</b>	<b>20</b>
<b>9. Communication Interface.....</b>	<b>20</b>
<b>10. Protocols.....</b>	<b>21</b>
<b>11. Operating Systems Support.....</b>	<b>21</b>
<b>12. Peripheral Facilities Supported.....</b>	<b>22</b>
12.1 MCL SR3 / SR5/Condor (ccTalk):.....	22
12.1.1 Number of units supported:.....	22
12.1.2 Coin Routing Control:.....	22
12.1.3 Inhibits.....	22
12.1.4 Automatic Coin Values.....	22
12.2 Lumina (ccTalk):.....	22
12.2.1 number of units supported:.....	22
12.2.2 Encryption.....	22
12.2.3 Inhibits.....	22
12.2.4 Automatic NOTE Values.....	22
12.3 Ardac 5 / MC2600.....	22
12.3.1 Number of units supported.....	22
12.3.2 Inhibits.....	22
12.3.3 Note Values.....	22
12.4 Serial Compact Hopper / Universal Serial Hopper (ccTalk):.....	23
12.4.1 Number of units supported:.....	23
12.4.2 Encryption.....	23
12.5 External Switches:.....	23
12.5.1 number Supported.....	23
12.5.2 Switch Facilities.....	23
12.6 External LED's:.....	23
12.6.1 number Supported.....	23
12.7 Starpoint Electronic Counter:.....	24
12.7.1 Number Supported.....	24
12.7.2 Number Of Counters.....	24
12.7.3 BACTA Standard.....	24
12.7.4 Error Checking.....	24
<b>13. Appendix 1 – Connector Details and Crimps.....</b>	<b>25</b>

## Tables

Table 1: Power Supply .....	20
Table 2: Environmental Ranges .....	20
Table 3: Hopper Address v Coin Value .....	23

## Figures

Figure 1: PCI ccTalk Connector.....	14
Figure 2: Lumina / SR5 ccTalk Connector.....	14
Figure 3: SR3/Condor Plus ccTalk Connector .....	15
Figure 4: SCH2 ccTalk Connector .....	15
Figure 5: SUH ccTalk Connector .....	16
Figure 6: I-O Connectors J7 & J8 .....	17
Figure 7: SEC Meter Connectors.....	18
Figure 8: MC2600 /RJ-45 Connector .....	18
Figure 9: Ardac5 Connector.....	19

# 1. Diary of changes

- Issue 1.0 .....December 2003
  - 1<sup>st</sup> Issue
  
- Issue 1.1 .....January 2003
  - Ammended error in [Appendix 1 – Connector Details and Crimps](#) (Lumina / SR5 8 way connector to 10 way).
  
- Issue 1.2 .....June 2004
  - Changed footer
  
- Issue 2.0 ..... July 2004
  - Changed layout – added info on Ardac connector

## 2. Introduction

### **Applications:**

The Money Controls' ccTalk PCI interface board is a simple, compact system that offers trouble free interfacing between a PC and money handling Equipment. The ccTalk PCI board has been developed as a cost effective high performance solution, ideally suited to the AWP, Amusement Games, Leisure and Change Machine industries.

### **PCI interface:**

The ccTalk PCI Card plugs into a PCI slot on a motherboard, a resource that is always available on the PC units used in the industry. As none of the standard PC ports are used to communicate with the money handling peripherals, the full facilities of the PC are still available to the system designer.

### **Simple Application Program Interface:**

The ccTalk PCI Card provides PC programmers with an API designed to make their life easy, with a rich set of function which are designed to provide the functionality they want, without getting involved in the detail of communicating with the peripherals.

### **Low cost, High Performance:**

The ccTalk PCI Card allows PC programmers to interface easily to a wide range of money handling and associated units.

### **Multi-Protocol:**

The ccTalk PCI Card was specifically designed from the outset to offer a single PC interface to money handling equipment though many different protocols and connections.

### **Upgrade Capability:**

The ccTalk PCI Card handles all the details of communicating with money handling equipment. This means that as new units are developed and existing units enhanced, the PC programmer continues to see the same interface.

### **In Summary:**

- Device independent Application Programming Interface.
- All standard PC ports left free.
- Standard PCI slot interface.
- Low Cost High Performance Solution.
- ccTalk Device support
  - ccTalk coin acceptors (SR3, SR5, SR5I, Condor Plus)
  - ccTalk note acceptors (Lumina)
  - ccTalk Hopper (Serial Compact Hopper MK2, Serial Universal Hopper)
- Multi protocol Support
  - Ardac2 (Ardac5, MC2600)
- Auxiliary Device support
  - Up to 16 LED's / low power lamps / relays or Industry-standard switches
  - Serial Electronic Meter
- Future proof PC programming.

### 3. Outline Specification

#### 3.1 Functional Block Diagram

The following diagram shows the main features of the card:

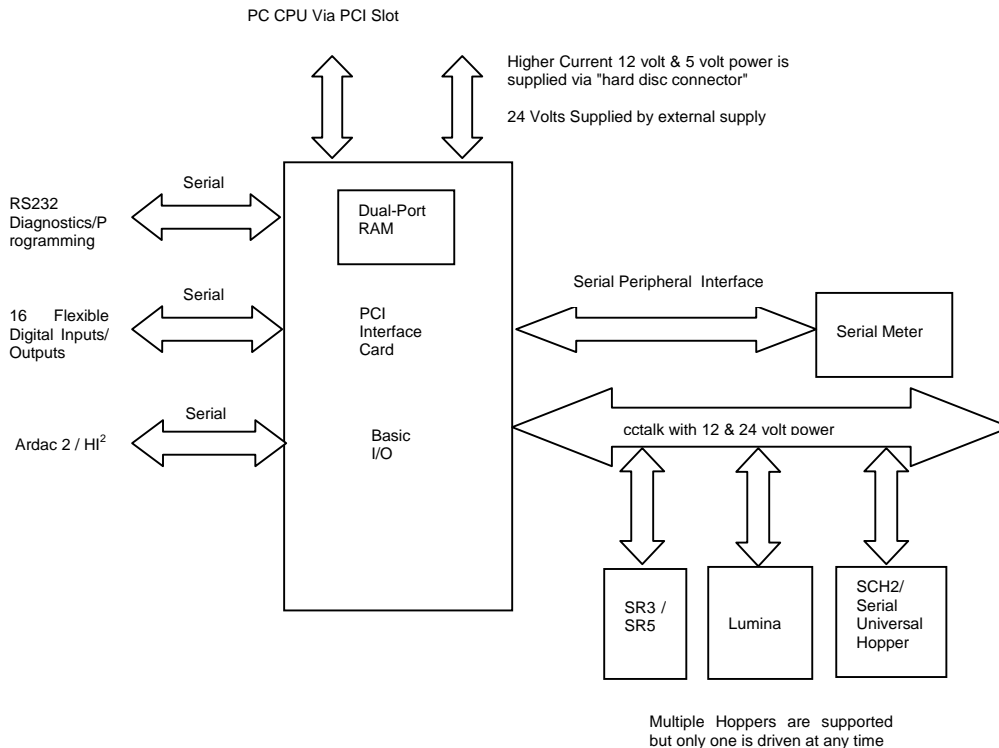

- Fits into standard PCI slot and communicates with the PC CPU at "bus speeds".
- Powerful 16-bit micro controller on the card to allow a range of peripherals to be supported with no change to the PC applications software.
- Fully field upgradeable as new peripherals become supported.
- Supports a range of ccTalk peripherals, each running either at 12 volts or 24 volts, from Money Controls.
- Drives 16 industry-standard switches and LED's. The 16 may be split in number as required. Each switch and LED is provided with 9 mA from a current source.
- Optional 256 Kbytes of onboard log. This can be interrogated from the LCD/ switch module (available soon) regardless of whether the PC power is applied or not.
- Flexible expansion bus, available both internally and externally.
- Takes 12-volt power from the PC power supply, via a standard "hard disc" connector mounted on the board.
- Takes 24-volt power from an external power supply.
- Software support for the "Windows" family of operating systems.
- Linux drivers available soon.

These features will be described in a little more detail later in the document.

### 3.2 Annotated Picture

This is an image of a production card, with the various connectors and features highlighted and identified.

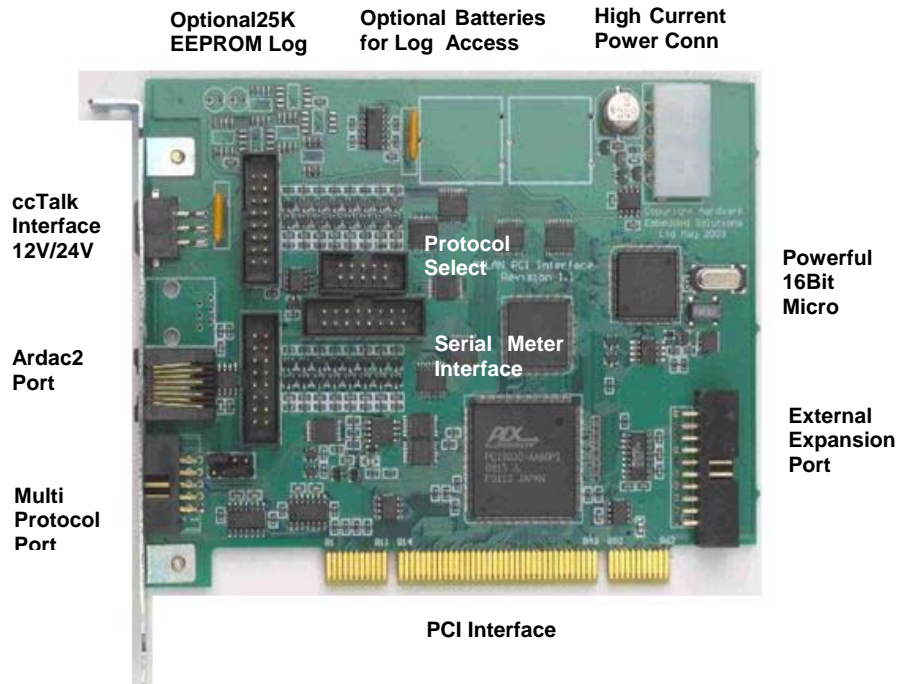

### 3.3 Feature Description

1. The hub card fits into standard PCI slot and communicates with the PC CPU at "bus speeds".  
This means that an application running on the PC can communicate directly with the card at high speed simply by reading and writing into shared memory.  
There are no requirements for (say) worker threads on the PC to handle any serial protocol timing requirements.
2. The card is fitted with a powerful 16-bit micro controller.  
This microcontroller is responsible for communicating with the peripheral devices in use and presenting a clean and consistent interface to the PC.  
By use of this scheme it is possible to *change* the peripherals in use in an application without the PC application having to change.  
All communication protocols are supported by the micro controller, so there is no communications software to be written on the PC.
3. The hub card supports a range of ccTalk peripherals, each running either at 12 volts or 24 volts.  
These include a wide range of products from Money Controls.  
It is possible to support up to eight hoppers, though these only operate one at a time.

4. Drives 16 industry-standard switches and LED's.  
The 16 may be split in number as required. For example, one may wish to drive 5 switches and 11 LED's.  
Each switch and LED is provided with 11mA from a current source. However, there is a low-cost daughter board available to drive higher current switches and standard lamps as used in SWP/ AWP machines.
  
5. As an extra-cost option, 256 Kbytes of onboard log can be fitted.  
Using the optional LED/ switch module (available soon), the log can be interrogated regardless of whether the PC power is applied or not.  
This is designed for support personnel to be able to read out (for example) cash throughput information.  
The hardware is provided to support "i button" devices to allow operator identification, though there is no software support for these at time of writing.
  
6. To allow unlimited flexibility, a high speed and flexible expansion bus has been provided. This is available both internally and externally, and allows for specialised functions to be added in the future.
  
7. The hub card takes 12-volt power from the PC power supply, via a standard "hard disc" connector mounted on the board. The reason for this is that the power required for the hopper is too great to be taken from the PCI connector.  
The 12-volt output to the peripherals is taken via a self-recovering fuse, to protect the output against short circuits.

**Note:- It is necessary to have the "hard disc" power attached or the card will not function at all.**

8. The hub card takes 24-volt power from an external power supply, as this is not normally available within a PC.  
The 24-volt output to the peripherals is taken via a self-recovering fuse, to protect the output against short circuits.
  
9. Full software support for the "Windows" family of operating systems is available today.  
Linux drivers are currently under development and will be available soon.



## 4. Operation

### 4.1 Hardware Installation.

Before you start the installation, turn off the power to your system and discharge your body's static electric charge by touching a grounded surface—for example, the metal surface of the power supply—before performing any hardware procedure.

The manufacturer assumes no liability for any damage, caused directly or indirectly, by improper installation of any components by unauthorized service personnel. If you do not feel comfortable performing the installation, consult a qualified computer technician. Damage to system components, the accelerator card, and injury to yourself may result if power is applied during installation.

Now that you have prepared your computer, you are ready to install your ccTalk PCI interface card.

To install your interface card, power off the computer, then remove the computer cover. If necessary, consult your computer's manual for help in removing the cover.

Remember to discharge your body's static electricity by touching the metal surface of the computer chassis.

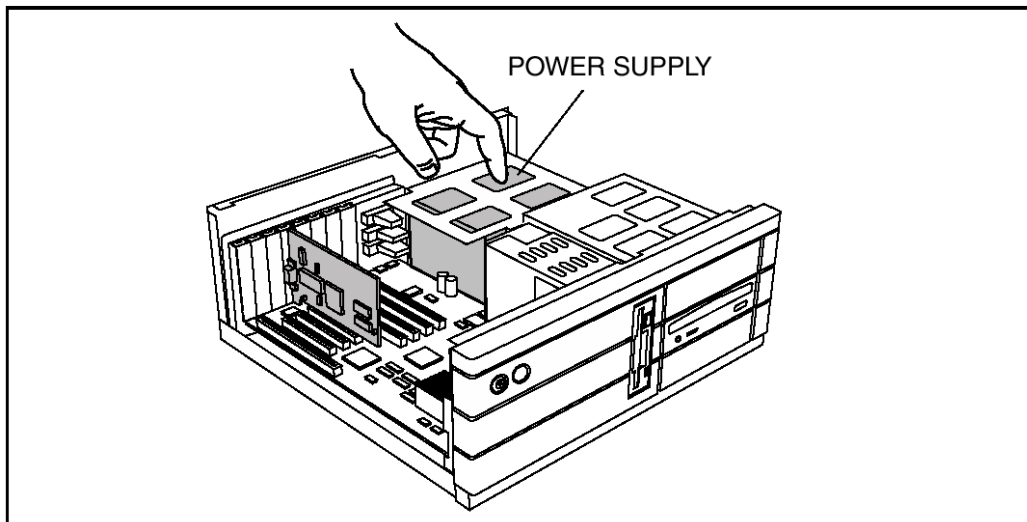

Locate a free PCI slot. If necessary, remove the metal cover from this slot; then align your ccTalk PCI Card with the PCI slot, and press it in firmly until the card is fully seated. Ensure that the metal contacts are completely pushed into the slot.

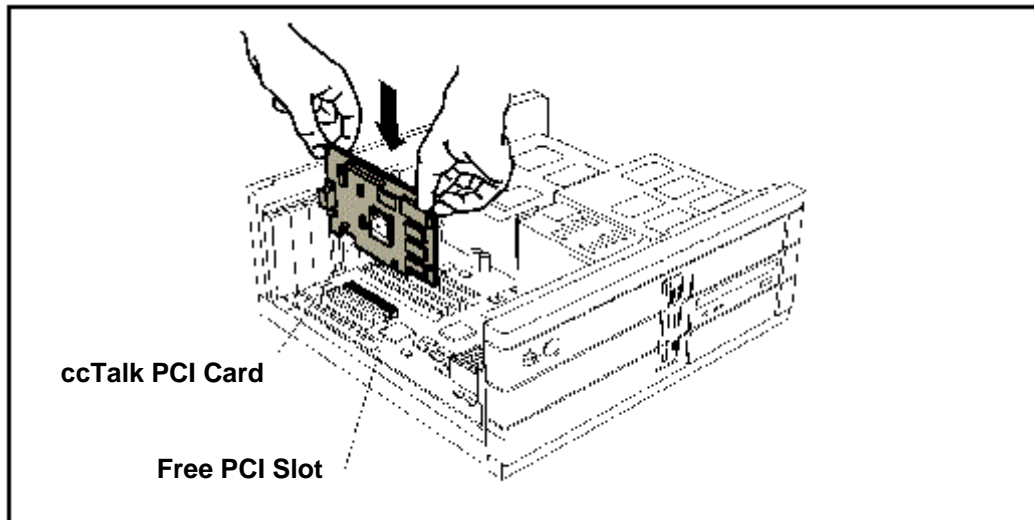

Replace the screw to fasten the card in place, and replace the computer cover.

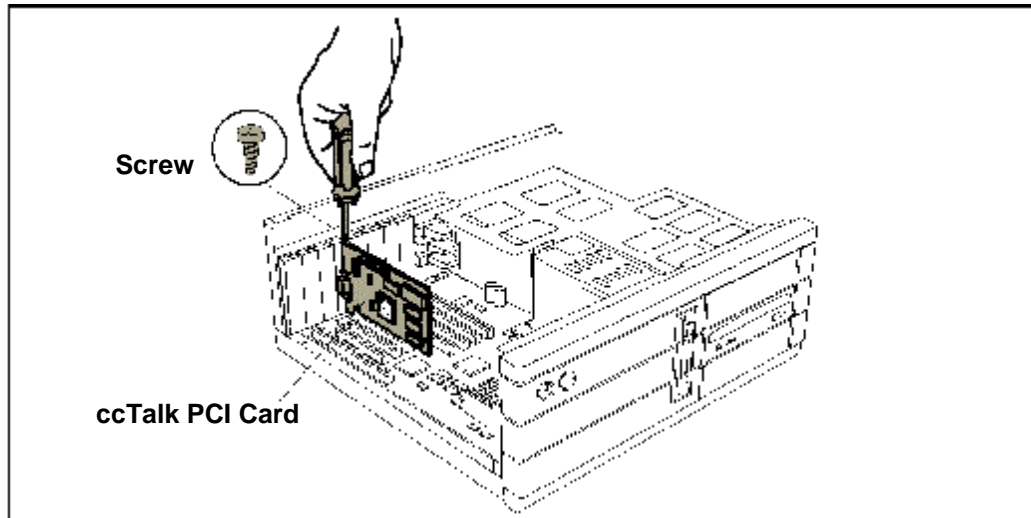

You are now ready to proceed with the installation of the Software Drivers.

## 4.2 Software Installation (under XP)

The ccTalk PCI board is integrated into the Windows operating system as with any other modern peripheral. When the operating system detects the presence of a ccTalk PCI board it requests the CD containing the low level driver and interface DLL (both provided by MCL) and automatically installs them.

At start up XP will detect the presence of new hardware and automatically launch the Hardware Update Wizard.

Initially the welcome screen is displayed.

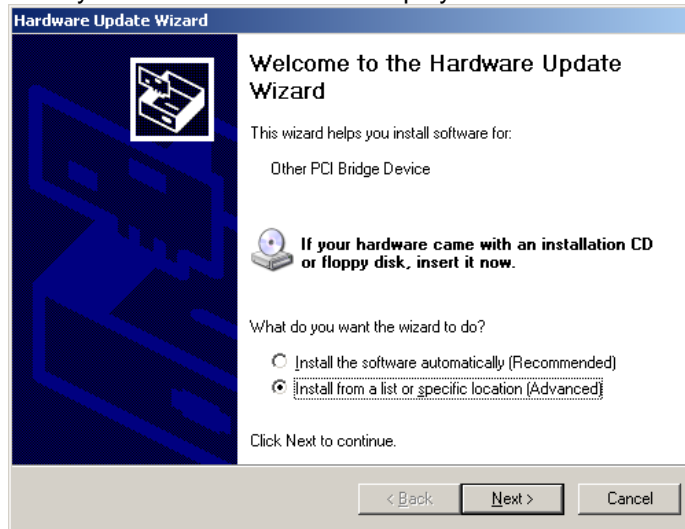

Choose the “Install from a list or specific location (Advanced)” option.

Click next and the search options dialog is displayed:

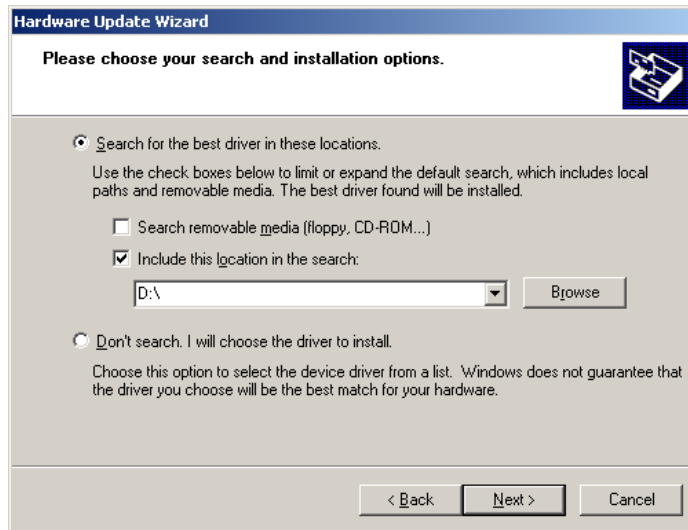

Ensure that the MCL software CD is in the CD drive, check the “Include this location in the search:” option and either use the browse button to find the CD Drive, or type the drive letter into the box.

*Note that if for some reason you have received the software via e-mail, then at this point you would use the browse button to locate the “Distribution” folder from the e-mail attachment.*

Click next and the hardware selection dialog is displayed:

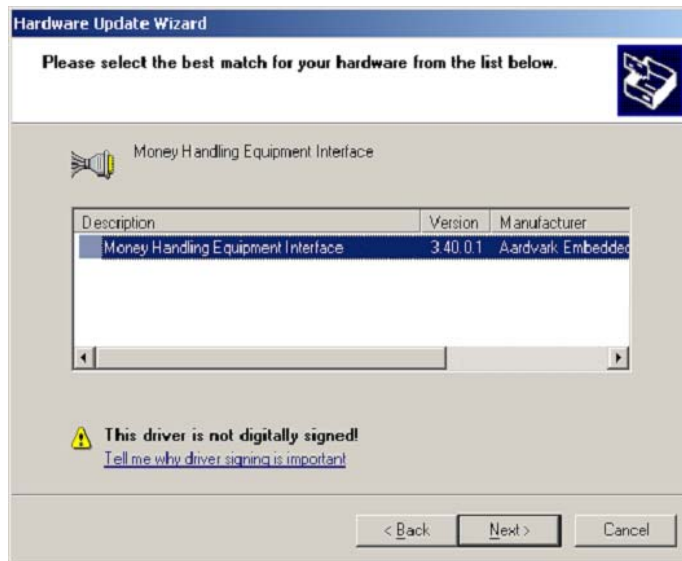

There should only be the one item shown, if there is more than one then choose the Money Handling Equipment Interface entry with the latest version.

Click next, and the warning about Windows Logo testing will be display.

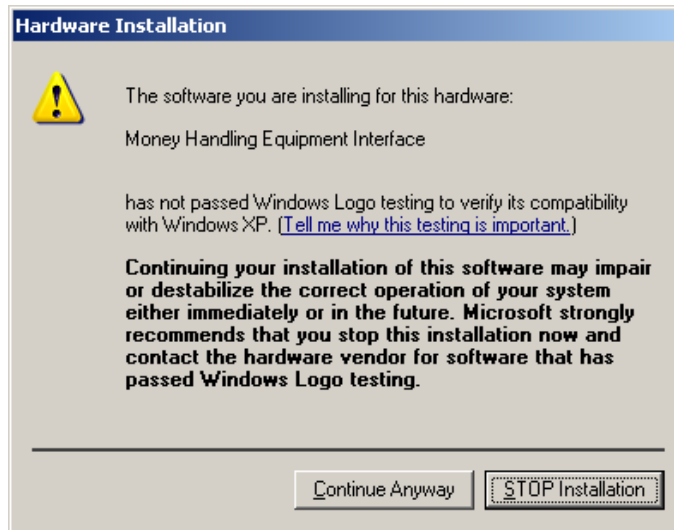

Click "Continue Anyway" and the driver and DLL will be installed. When all this has happened, the final screen will appear.



Click Finish and your ccTalk PCI Interface board is now ready for use.

### 4.3 Software Development.

The provided DLL supports the Application Program interface (API) that has been defined to communicate with ccTalk PCI board and hence its external peripherals. The supplied CD contains all the resources needed by a programmer in order to use this DLL. In addition, there are a number of sample programs to make clear its operation, and to allow the functioning of a system to be proven before the application development is started.

The API is described in detail in the accompanying manual (TSP091.doc).

## 5. CcTalkConnections

### 5.1 PCI ccTalk Connector

Figure 1: PCI ccTalk Connector

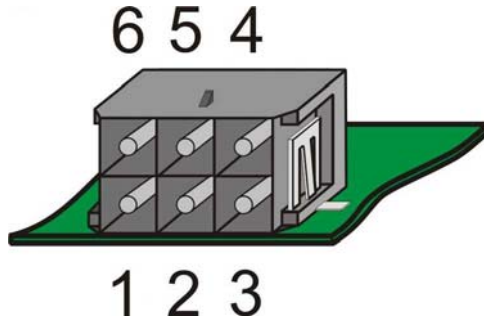

Pin	Function	Pin	Function
1	ccTalk	4	+24V Out
2	+12V Out	5	0V In
3	Serial Select / 0V	6	+24V In

### 5.2 Lumina / SR5

Figure 2: Lumina / SR5 ccTalk Connector



Pin	Description	Pin	Description	
			Lumina	SR5
1	Data (ccTalk)	9	Not Used	Serial Select
2,3,4,5,6	Not Used		Not Used	Not Used
7	12V	10	Not Used	
8	0V			

### 5.3 SR3/Condor Plus

Figure 3: SR3/Condor Plus ccTalk Connector

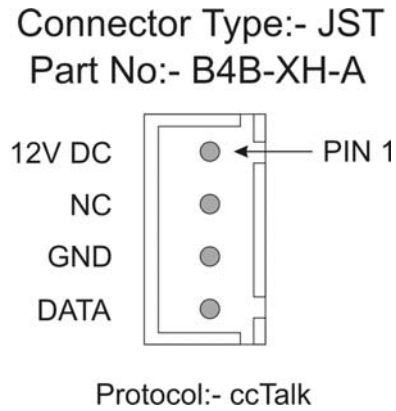

### 5.4 Serial Compact Hopper 2

Figure 4: SCH2 ccTalk Connector

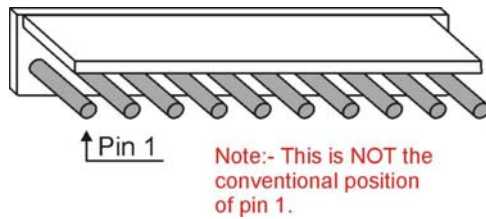

Pin	Function	Pin	Function
1	Address select 3 - MSB	6,7	0V
2	Address select 2	8	/DATA ( ccTalk )
3	Address select 1 - LSB	9	N/C
4,5	+Vs	10	/RESET

### 5.5 Serial Universal Hopper

**Peripheral connector :**  
Cinch R76-77848 12-way male

*Figure 5: SUH ccTalk Connector*



View of Baseplate  
Connector from Rear

Pin	Function	Pin	Function
1	0V	8	Address Select 2
2,3	N.C.	9	+Vs
4	Address Select 1 - LSB	10,11	N.C.
5	/DATA ( ccTalk )	12	Address Select 3 - MSB
6,7	N.C.		



## 6. Input / Output Connectors

Figure 6: I-O Connectors J7 & J8

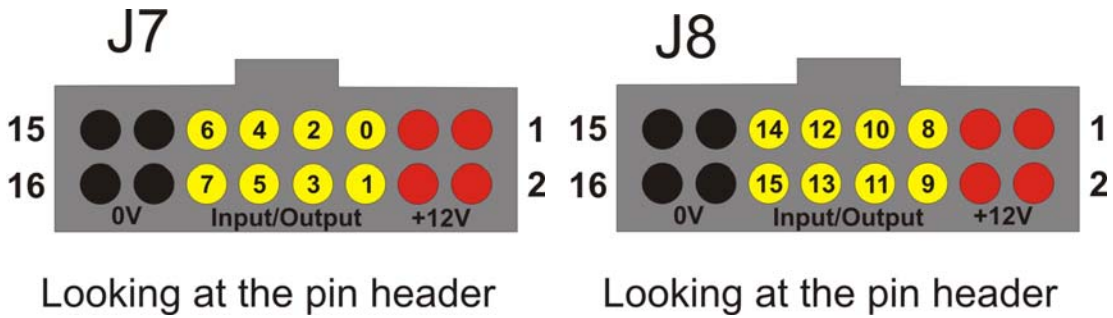

Output Characteristics	
<b>Current Source:</b>	11mA @ 10V

Input Characteristics	
<b>Maximum:</b>	12V
<b>Threshold:</b>	Approx. 6.25V @ 0.6mA
<b>Minimum:</b>	6V

### 6.1 Switches

Switches may be implemented by connecting the I-O pin to the switch and the other side of the switch to GND.

## 7. Meter Connector

### 7.1 Meter Connector

Figure 7: SEC Meter Connectors

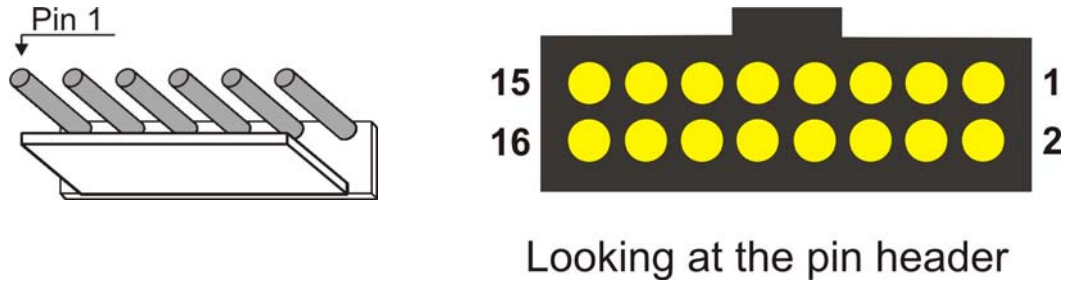

Pin (Meter)	Pin (PCI)	Function	Pin (Meter)	Pin (PCI)	Function
1	10	SPI Data Output	4	7	SEC Reset
2	5	SPI Clock Input	5	16	+12V Supply
3	8	SPI Data Input	6	15	0V Supply

### 7.2 MC2600 / RJ-45 Connector

Figure 8: MC2600 /RJ-45 Connector

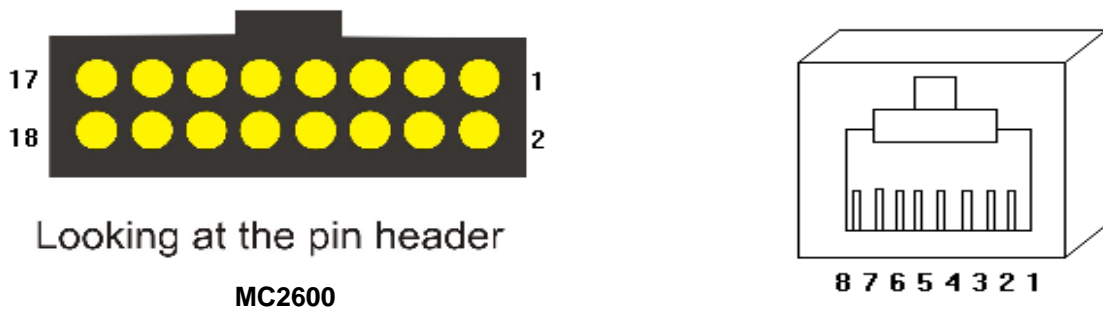

Pin MC2600	RJ-45 (PCI)	Function
11	3 (RX Green/White)	Rx Green/White
15	4 (Tx Blue)	Tx Blue
4	2 (GND Orange)	GND Orange
7	2 (GND Orange)	GND Orange

RJ-45

### 7.3 Ardac 5 Connector

Figure 9: Ardac5 Connector

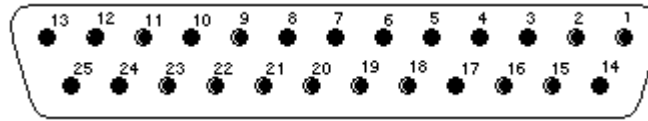

**Ardac5 25 Way D-type (Female) Connector**

Pin (Ardac5)	RJ-45 (PCI)	Function
2 (Rx Violet)	3 (Rx Green/White)	Rx
3 (Tx Yellow)	4 (Tx Blue)	Tx
7 (GND Green)	2 (GND Orange)	GND

## 8. Electrical Interface Requirements

*Table 1: Power Supply*

Standard hard drive power connector		
Voltage	12V	5V Logic
Current	3A	500mA

Output peripherals Note reader/Coin Acceptor	
Voltage	12V
Current	2.5A Continuous

Output peripherals e.g. Coin Hopper (Requires external power)	
Voltage	24V
Current	2.5A Continuous

*Table 2: Environmental Ranges*

	Min	Max
Operating °C range:	0	55
Storage °C range:	-20	+70
Humidity: RH non-condensing		Up to 75%

## 9. Communication Interface

PCI Version 2.1 & 2.2 supported.

Supports 5V0 and 3V3 PCI buses.

Maximum Current        300mA

## 10. Protocols

The following protocols are supported:-

1. **ccTalk** BACTA compliant implementation.
2. **Ardac2** Money Controls serial protocol for Ardac note acceptors
3. **Motorola SPI Mode 2** As defined by REV 3.4 of the Starpoint Document.
4. **Multiple Protocols Supported – Contact Technical Services for details.**

## 11. Operating Systems Support

Microsoft® Windows® 98/2000/XP/XP Embedded

## 12. Peripheral Facilities Supported

### 12.1 MCL SR3 / SR5/Condor (ccTalk):

#### 12.1.1 NUMBER OF UNITS SUPPORTED:

At present, only one coin acceptor, at address 2, is supported.

#### 12.1.2 COIN ROUTING CONTROL:

A complex system of routing is provided, which is intended to support, as a minimum, the diversion of given incoming coins to hoppers, automatically redirected to a cash-box when the hopper is full.

#### 12.1.3 INHIBITS

Both individual coins and the entire unit can be easily inhibited.

#### 12.1.4 AUTOMATIC COIN VALUES

The automatic retrieval from the unit of the value of each coin is supported.

### 12.2 Lumina (ccTalk):

#### 12.2.1 NUMBER OF UNITS SUPPORTED:

At present, only one note acceptor, at address 40, is supported.

#### 12.2.2 ENCRYPTION

The PCI board fully supports the ccTalk encryption scheme needed to communicate with bill validators.

**IMPORTANT:- The 6 digit security code MUST be 123456.**

This all means that users do not need to become involved in the details of the encryption scheme.

#### 12.2.3 INHIBITS

Both individual notes and the entire unit can be easily inhibited.

#### 12.2.4 AUTOMATIC NOTE VALUES

The automatic retrieval from the unit of the value of each note is supported.

### 12.3 Ardac 5 / MC2600

#### 12.3.1 NUMBER OF UNITS SUPPORTED

As Lumina

#### 12.3.2 INHIBITS

As Lumina

#### 12.3.3 NOTE VALUES

As version 4.1.8.14 Note Table

## 12.4 Serial Compact Hopper / Universal Serial Hopper (ccTalk):

### 12.4.1 NUMBER OF UNITS SUPPORTED:

Currently, 8 Hoppers, at addresses 3 to 10, are supported and the pre-set values are as follows:-

*Table 3: Hopper Address v Coin Value*

Address	Coin Value	Address	Coin Value
3	100	7	10
4	50	8	5
5	25	9	200
6	20	10	500

### 12.4.2 ENCRYPTION

The PCI board fully supports the ccTalk encryption scheme needed to communicate with these hoppers.

This means that users do not need to become involved in the details of the encryption scheme.

## 12.5 External Switches:

### 12.5.1 NUMBER SUPPORTED.

8 Individual external switches are supported by the unit, and are easily accessible by the user's application.

### 12.5.2 SWITCH FACILITIES.

Provision is made for the user's application to easily use switches in two modes:

1. **Key Press** Where a button may be pressed several times and it is important to know how many times
2. **State** Where the switch changes over a long time frame and all the application needs to know is where the switch is at any instant.

## 12.6 External LED's:

### 12.6.1 NUMBER SUPPORTED.

8 Individual external LED's are supported by the unit, and are easily accessible by the user's application.

## **12.7 Starpoint Electronic Counter:**

### **12.7.1 NUMBER SUPPORTED.**

One external meter with an SPI interface corresponding to that defined by Starpoint is supported.

### **12.7.2 NUMBER OF COUNTERS**

The PCI board fully supports all 31 of the Starpoint's counters

### **12.7.3 BACTA STANDARD**

Provision is made to allow the user's application to easily support the BACTA standard for displaying counter values, as well as to implement any other scheme.

### **12.7.4 ERROR CHECKING**

The PCI board continually checks that the meter is operation



### 13. Appendix 1 – Connector Details and Crimps

	Connector	Crimp
PCI ccTalk		
RS No.	233-2769	233-3009
SR3 ccTalk		
JST Part No.	XHP-4	SXH-001T-P0.6
<b>ccTalk SR5 / Lumina (10 way) Input / Output (16 way)</b>		
RS No.	360-6229 (10) 360-6207 (16)	360-6869
Serial Compact Hopper MK2		
RS No.	296-5022	467-598
Serial Universal Hopper		Not applicable
RS No.	466-078	Not applicable

This manual is intended only to assist the reader in the use of this product and therefore Money Controls shall not be liable for any loss or damage whatsoever arising from the use of any information or particulars in, or any incorrect use of the product. Money Controls reserve the right to change product specifications on any item without prior notice