

## Testing Flybacks And Yokes With The RINGER Test

Flybacks (conventional and IHVT) and yokes often develop shorted turns within their windings. This type of failure is impossible to find with any test other than the RINGER test. The RINGER test provides an accurate, easy-to-use method of isolating these failures. The RINGER test is included on many Sencore instruments. It approximates a "Q" test and works by pulsing the coil and counting the resulting number of rings (oscillations) that occur before dampening to the 25 percent level.

A capacitor is placed in parallel with the coil for impedance matching. The proper impedance is selected by rotating the IMPEDANCE MATCH switch to the position that produces the maximum number of rings as shown on the meter. (The LC77 and LC102 AUTO-Z Meters perform this impedance matching automatically.) If the highest readout is 10 or higher, the coil or transformer has no shorted turns. If the coil has shorted turns, the reading will be less than 10. The RINGER test will indicate a BAD reading of less than 10 if the coil has even one shorted turn.

If any of the primary or secondary windings of the flyback are shorted (even if the shorted winding is electrically isolated from the one you are connected to), the magnetic energy around the coil will be shorted out and the RINGER test will read less than 10 in all of the yoke and flyback positions of the IMPEDANCE MATCH switch.

An open in the winding you are connected to will also produce a bad (less than 10) reading. If you suspect that a winding other than the one you are connected to is open (because of the circuit symptoms), simply place a short across the suspected winding while you monitor the results on the winding you were first connected to. The reading on the RINGER test will drop if the suspected winding is good. The reading will not change if the winding that you applied the short to is open.

### To test a flyback:

1. Using a schematic, locate the winding connected to the collector of the horizontal output transistor. Follow this winding to identify the flyback lead that connects to the B+ supply.
2. Connect one of the RINGER test leads to the flyback lead that connects to the collector of the output transistor. Connect the other RINGER test lead to the flyback lead that connects to the B+ supply.
3. Push the RINGER test button, or turn the METER switch to the RINGING TEST position, depending on which unit you are using. Rotate the IMPEDANCE MATCH switch through its yoke and flyback positions noting the highest reading on the meter. If any of the

### How To Find Shorted Or Open Flybacks With The RINGER Test

To test a flyback you need to make only one set of lead connections to test all of the windings. If none of the windings contain a shorted turn and if the winding you are connected to is not open, the RINGER test will read 10 or higher on at least one of the positions of the IMPEDANCE MATCH switch. The "Z Meters" (other than the LC77 and LC102) have four switch positions, indicated by a red band, that are used for testing flybacks and yokes. Use only these four positions for testing yokes or flybacks. (Use all six positions for testing coils other than yokes and flybacks.)

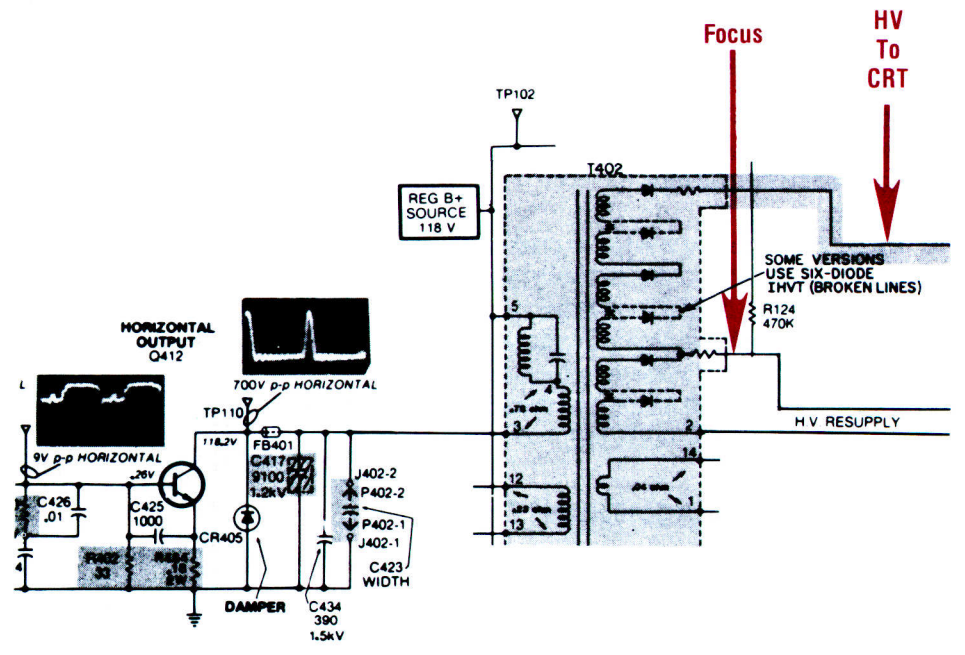

Fig. 1: Typical IHVT Circuit (RCA CTC108)

#116 9LL#

readings is higher than 10, you know the primary of the flyback is good, and none of the other windings are shorted.

4. If none of the positions of the IMPEDANCE MATCH switch reads higher than 10, isolate the most likely loading circuits by disconnecting them in the following order: yoke, CRT filament (unplug socket), collector of the horizontal output transistor, and one end of the rectifier diode in each of the low-voltage supplies powered from the flyback.

After each circuit is disconnected, retest the flyback. If the flyback rings good after one of the loads is disconnected, the flyback is not shorted. Be sure to check the load that was just disconnected, however, for possible defects. (Note: In many cases these circuits, even if good, may normally cause the flyback to ring less than 10.)

5. If the flyback continues to test bad in the circuit after disconnecting each of these loads, continue disconnecting the individual windings. If the flyback still rings less than 10 in every yoke and flyback switch position with all loads disconnected, it is bad and must be replaced.

#### Tips on testing flybacks out of circuit:

1. Connect to the same flyback pins used for the in-circuit test and perform the RINGER test.

2. Do not lay the flyback on a metal surface, as the metal may affect the flyback in the same way as a shorted turn.

3. The core and spacers must be in place to test the flyback. Without them, the flyback will always test bad. If the replacement flyback comes without the ferrite core and mounting hardware, be sure to remove them from the chassis and install them on the new flyback before performing the RINGER test.

#### A Final Tip For Absolute Confidence

If you ever have a doubt of whether a reading of less than 10 actually means that a flyback has a shorted turn, there is a simple, additional test you can perform to remove any doubt. While ringing a flyback, wrap a turn of solder around the core and touch the ends of the solder loop together. If the flyback was already shorted, the shorted solder loop will have very little additional affect and the read-

ing will drop one count or less. If the flyback was not shorted, the solder loop will now cause the reading to drop significantly.

#### Test For Leakage Between Windings

Some flybacks may cause overcurrent shut-down in the chassis, yet test good with the RINGER test. The cause of this problem is usually leakage between different windings in the flyback section of these flybacks, or leakage between a winding and the core or mounting bracket. Sometimes the windings have a zero resistance short that can be found with an ohmmeter, but many times the leakage only occurs when a higher voltage is applied.

If the flyback passes the RINGER test but you suspect possible leakage (the chassis draws excessive current, blows horizontal output transistors, or shuts down) check the flyback using the LEAKAGE test found on one of the Sencore Z Meters. The LEAKAGE test checks the windings for breakdown with normal circuit voltages applied. It will find leakage between separate windings, or leakage to the core that goes unnoticed with other tests. Check leakage with both polarities of applied voltage by reversing the leads. This is necessary because the leakage path sometimes involves a diode which is only forward biased by one polarity of applied voltage.

The leakage test must be performed with the flyback completely out of circuit. Set the Z Meter to its maximum Leakage Voltage setting, either 600 or 1000, depending upon the model. The leakage between windings, and between each winding and the core should drop to 0.0 A. If any current is measured, the flyback should be replaced.

#### How To Ring Yokes

The tests of the deflection yoke are very similar to the flyback test. Test each of the four yoke windings separately. The two vertical windings, for example, should both show the same number of ringing cycles in the same position of the IMPEDANCE MATCH switch. If the yoke is open or has a shorted turn it will show a reading of less than 10. If it is not open or shorted it will show a reading of 10 or higher.

Each winding must be individually tested because a short in one of the yoke windings is less likely to couple to the other windings than are the closely coupled windings of a flyback. Also, if two windings are in parallel, an open in one of the windings will not be detected unless the two windings are tested separately. Since there are only four windings involved, however, this adds very little time to the test.

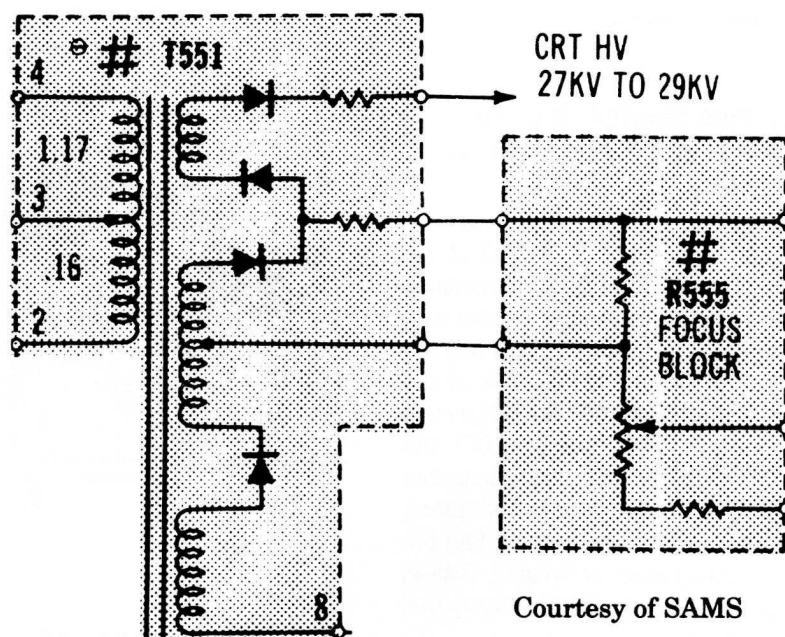

Courtesy of SAMS

Fig. 2: Use the Z Meter LEAKAGE test to find shorts between flyback windings. Reverse the test leads to check leakage with both polarities of applied voltage.

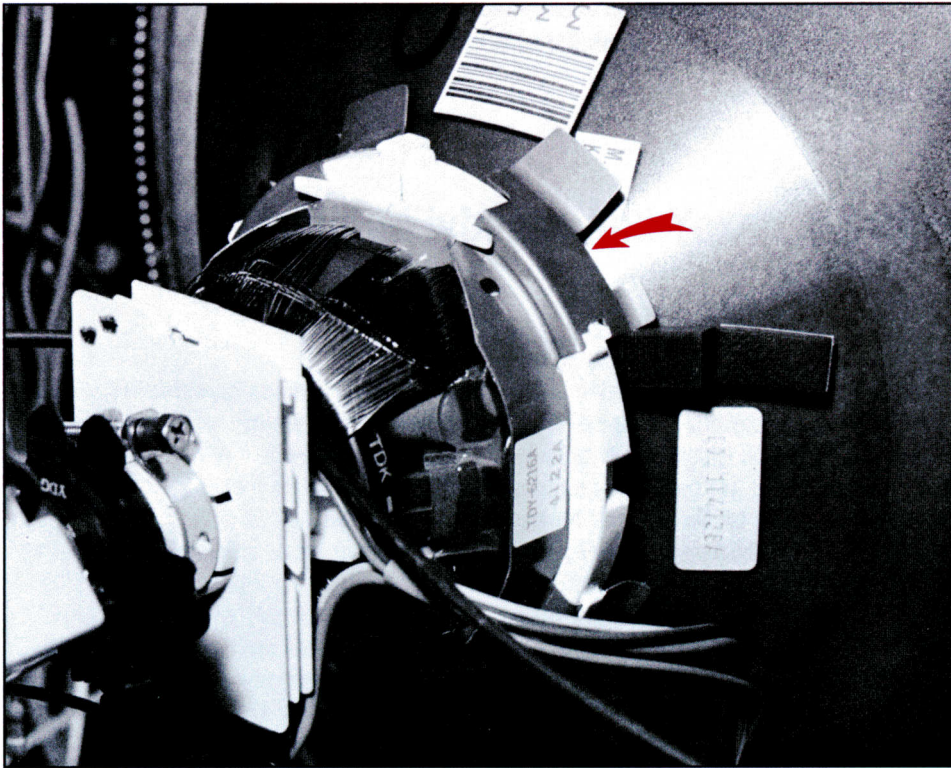

*Fig. 3: The metal band surrounding many toroidal yokes causes the vertical windings to ring lower than normal. A good vertical winding of this type rings 5 or higher.*

#### Tips on testing yokes:

1. Whenever possible, test the yoke with it mounted on the CRT. Sometimes the pressure of the yoke mounting hardware causes a short. Removing the yoke relieves the pressure which may clear the short.
2. The damping resistors for the vertical windings must be disconnected before doing the RINGER test or they will cause the windings to read bad, even if they are good. Sometimes the damping resistors are

mounted under the plastic terminal cover on the yoke. In other sets they are on the chassis, and are disconnected when the yoke plug is disconnected.

3. If you must trace wires to determine which yoke coils, remember that the vertical windings are located at the sides of the yoke. The horizontal coils are located on the top and bottom of a conventional saddle yoke and are the toroidal windings on toroidal-type yokes.

4. Do not test the yoke on a metal surface as the metal may act like a shorted turn and cause all tests to show bad.

5. The horizontal yokes found in SCR-drive receivers read only about 8 rings on the position of the IMPEDANCE MATCH switch that gives the highest reading.

6. Some toroidal yokes have a metal band surrounding their front perimeter, as shown in Figure 3. The metal band causes the yoke to appear as though it has a shorted vertical winding when you perform the RINGER test. Instead of 10 rings, use 5 as the cutoff point for these vertical windings. A bad vertical winding in this type of yoke will ring 0 or 1, while a good winding will ring 5 or higher. The RINGER test on the horizontal windings in these toroidal yokes is not affected by the metal band.

*For more information,  
Call Toll Free 1-800-SENCORE  
(1-800-736-2673)*

**SENCORE**

3200 Sencore Drive, Sioux Falls, South Dakota 57107

# Notes: