

SENCORE®

Means Success In Electronic Servicing

tech tips

Solving Capacitor Troubles With Your Z METER™

With all the ICs being used today, it may seem that fewer discrete components would be used. It might surprise you to learn that more capacitors are used in today's modern solid-state chassis than were used in the old tube sets. Sencore Engineers counted the capacitors and coils used in three comparable color televisions, a newer solid-state set, a tube set, and an RCA CTC131. The tube set had 219 capacitors; the new solid-state set had 263 capacitors, and the *RCA CTC131 had 665 capacitors!*

The Electronic Industries Association reported, in their 1987 Electronic Market Data Book, that factory sales of capacitors

increased from \$438 million in 1972 to \$1.217 billion in 1986. Also, reported was a 23.5% increase in the number of capacitors being used between 1985 and 1986. Naturally capacitors, and the problems associated with them, are here to stay.

Capacitors fail in-circuit, and they also fail just lying in the parts bin. The failure can be traced to one of four things; value change, excessive leakage, excessive dielectric absorption (D/A), or high Effective Series Resistance (ESR). A Z Meter is the only capacitor analyzer on the market that lets you make all four of these important tests. In this Tech Tip,

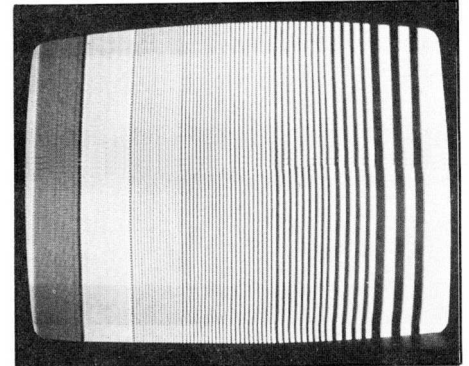

Fig. 2: A television with ripple in the picture, such as the set shown here, usually has a problem with one of its power supplies. Is the problem a loaded down supply, a bad rectifier diode, or a bad filter cap?

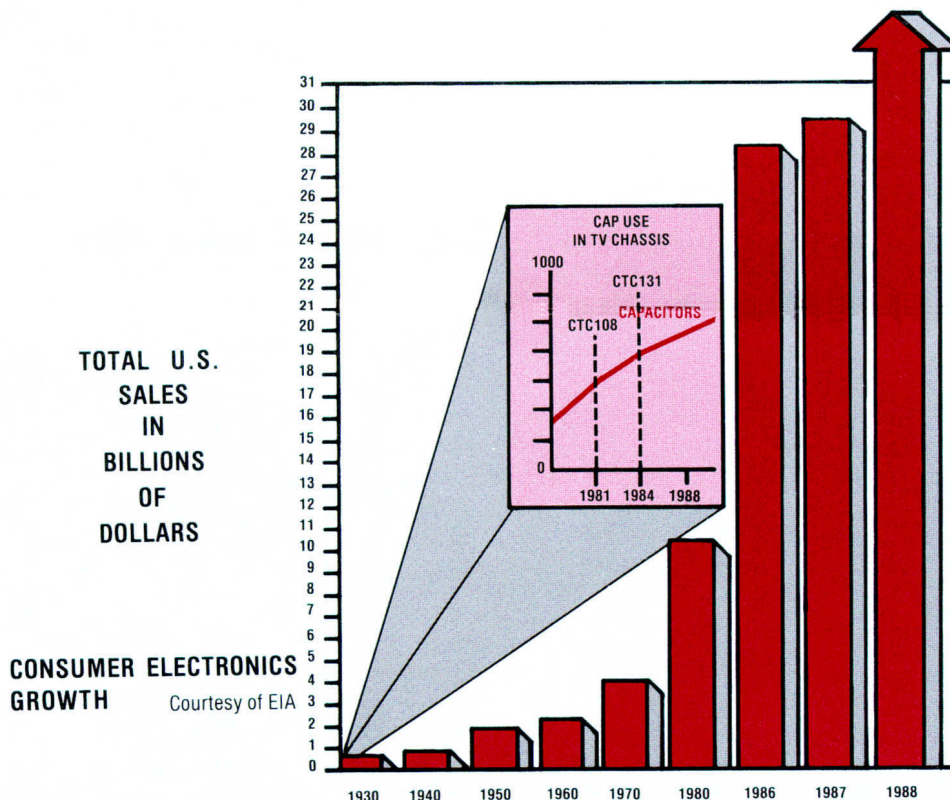

fig. 1: The RCA CTC131 chassis contains 665 capacitors compared to the 1981 CTC108 chassis with only 263 capacitors.

we're going to take a look at some actual case histories of capacitor related problems. Soon you'll see why you need a Z Meter.

Capacitors Change Value

How often have you seen a set that has the "bends" or 60 Hz ripple, like the set shown in Figure 2? What is causing the problem? A bad rectifier, a bad filter choke, a bad filter capacitor, a circuit loading a power supply, or a combination of several things could be the cause.

In the set shown here, we found that a 900 μ F, 350 VDC filter capacitor had decreased in value; it only measured 500 μ F.

Only about 25 % of the problems associated with capacitors are value related. Three out of four failures are caused by other problems. A "value only" capacitance meter isn't enough to find most of the capacitor problems in today's circuits.

Dielectric Absorption - The Hidden Failure

One common problem associated with capacitors is dielectric absorption (D/A). D/A is one of those "mystery" problems. You won't find it with a value only tester, Dielectric absorption can cause very real circuit problems. Let's consider the experience of one of our customers to see the effect of D/A.

A customer was convinced that the Z Meter which he had recently purchased was not finding bad capacitors. The capacitors were 22 μF and were located in the vertical stage of a television. The customer knew that the capacitors were bad because replacing them cured the linearity problems every time. The tests they performed with the Z Meter turned up nothing.

Measuring one of these capacitors on the Z Meter showed a value of 24.5 μF and less than the maximum allowable leakage. It sure appeared to be a good capacitor, However, by pressing the value button a second time after measuring the leakage, the customer found that the value measured 13% lower than it did before he measured leakage. As he continued to hold the value button, the reading steadily increased to its first value. The Z Meter was showing the capacitor as bad, having a 13% dielectric absorption value change.

Any capacitor that has more than 5% D/A should be questioned, especially in a critical waveshaping circuit like the vertical stage of a TV.

Dielectric absorption is the result of a capacitor remembering a charge that was applied to it. The results of this D/A "memory" vary, depending on the circuit the capacitor is in. In the previous example the capacitor was not allowing the vertical ramp to be properly shaped. As the voltage on the capacitor changed, the memory effect of D/A opposed the change, resulting in a non-linear picture.

Some circuits (like this vertical stage) will be severely affected by D/A. In other cases, a small amount of D/A tells you that the capacitor has aged to the point where it should be replaced, even if it isn't causing a circuit problem yet because it is near the end of its life.

Capacitor Leakage Upsets Bias Voltages

Capacitors are supposed to block DC while

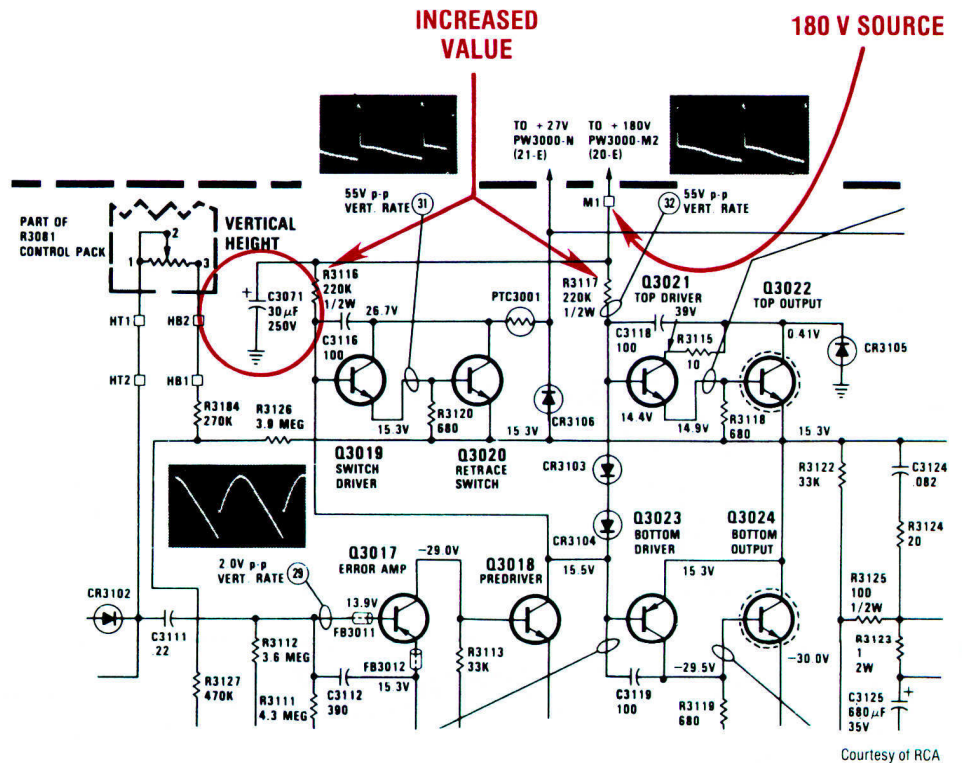

Fig. 3: This schematic shows the vertical output stages of an RCA CTC97 chassis. Even after the defective transistors and bias resistors were replaced, the 180 volt power was low. The problem was traced to a leaky filter cap, C3071.

passing an AC signal. When a capacitor develops leakage, it allows DC current to pass through in large amounts. This causes bias voltages to become incorrect and power supplies to load down. That is what happened with one particular chassis.

The set came in for repair having only a single horizontal line across the screen. Several quick checks isolated the problem to the vertical output stage. A little closer analysis of the output stage showed that most of the transistors were biased into cutoff. When the technician checked the transistors, he found that most of them were bad.

Further checking showed that the bias resistors (See Fig. 3), R3116 and R3117, had greatly increased in value. When they were replaced, a full raster returned, yet a continuous flickering indicated that something was still wrong. Measuring the voltage at M1 showed that the 180 volt supply was low, even after all the transistors and related bias components were confirmed good.

One possible culprit remained - C3071. The capacitor's value was OK, but the Z Meter leakage test showed high leakage. The capacitor had so much leakage that it was acting like a resistor and loading down the 180 volt power supply.

While a leaky capacitor acts like a resistor, you cannot find a leaky cap with an ohmmeter or even a voltmeter. Leakage in a capacitor is not linear; it depends on the voltage applied to it. The only way to determine if a capacitor has leakage is to measure the current through it with its rated voltage applied (Figure 4).

Maximum Allowable Leakage (in microamps) for Standard Aluminum Electrolytic Capacitors

Capacity in μF	3V	6V	10V	15V	25V
1	5	5	5	5	5
3	5	5	5	5	5
5	5	5	5	5	6
10	5	5	5	8	13
15	5	5	8	13	20
20	5	6	10	15	25
25	5	8	13	20	30
30	5	9	15	25	40
35	6	10	18	28	45
40	6	12	20	30	

Fig. 4: The acceptable leakage for a capacitor depends on its value and voltage rating. order to be sure that a capacitor is good, you must measure leakage with the cap's rated voltage applied.

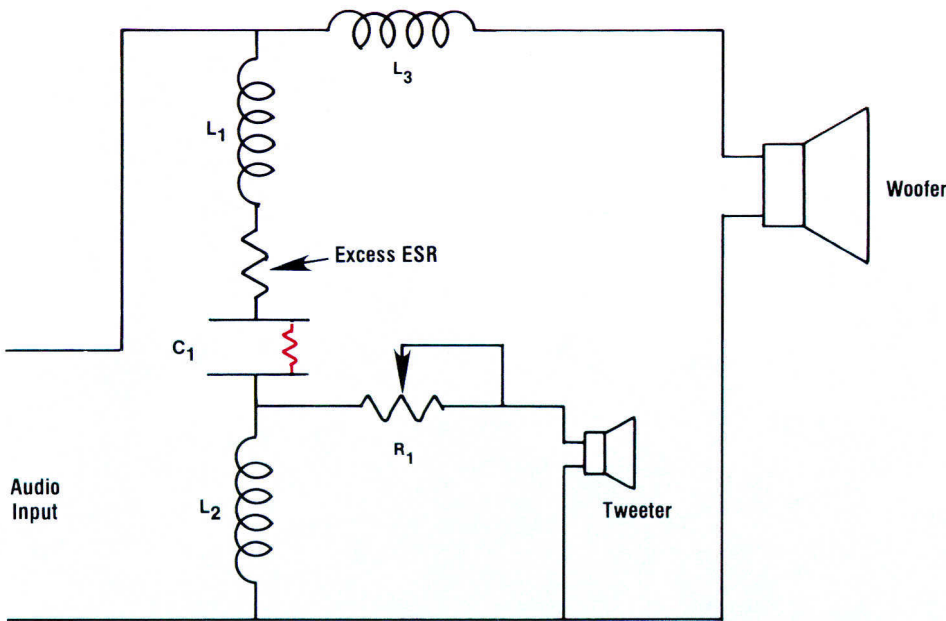

Fig. 5: Schematic of a speaker crossover network. In this circuit, C1's ESR had limited the signal delivered to the Tweeter.

ESR Is More Of A Problem In Today's High Frequency Circuits.

ESR is the Effective Series Resistance of a capacitor. It is a standard characteristic, expressed in ohms, that represents all of the energy losses in the capacitor, despite the source. Capacitor ESR is a combination of lead resistance, foil/capacitor plate resistance, resistance of the lead welds, and the energy lost in the dielectric itself.

ESR robs power from the circuit. Charging current flowing into and out of the capacitor must flow through the ESR.

Energy is lost in the form of heat. In power supplies operating at 60 Hz, heat loss is fairly low. However, in many modern circuits, such as switching mode power supplies, the operating frequency is in the kilohertz range. This causes the current to flow at a higher rate, and the heating effect increases.

ESR decreases the ability of a capacitor to filter correctly. In effect, you are placing a resistor in series with the capacitor. ESR also affects the time constant in critical timing circuits. Let's look at an example of the failures caused by high ESR.

Example: In one defective speaker system, there was no output from the high frequency tweeter. It was suspected that this speaker had been damaged by excessive power. The tweeter was checked and, as suspected, found to be defective. When the new tweeter was installed, the output was low and distorted. New suspect? The crossover network. It was the only other component that could cause a loss of high frequencies in this unit. Figure 5 shows the schematic of the crossover network. Notice that the only components that could affect the output to the tweeter are L1, L2, C1, and R1. The high frequency level control, R1, was checked; it tested good.

Capacitor C1 was removed from circuit and checked. The value read well within the tolerance range for this capacitor. Leakage and dielectric absorption were within acceptable limits. ESR was tested, it measured 176 ohms. The Z Meter pull chart showed that this capacitor was allowed 33 ohms of ESR (maximum). Since this capacitor was in series with the level control, it dropped most of the signal and decreased the speaker output.

Check Replacement Caps Before You Put Them In Circuit

Don't count on replacement capacitors being good; capacitors change value, become leaky, increase in ESR, and develop dielectric absorption just setting on the shelf (Figure 6). You should always

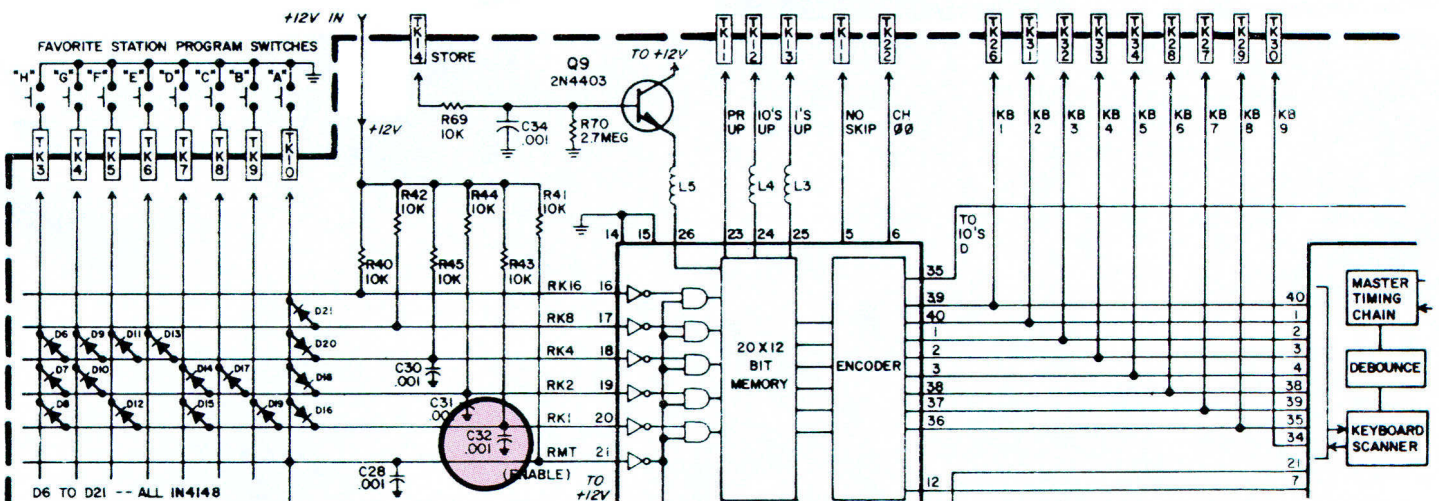

Courtesy of Sylvania

Fig. 6: In this Sylvania set, C32 shorted causing the set to stay locked onto one channel. The replacement capacitor was also defective, resulting in the set randomly tuning channels.

check a replacement capacitor before installing it.

Value Change Is Common In Electrolytics

Electrolytic capacitors have a moist, "paste-like" dielectric. The capacitor's body is sealed to prevent air from drying out the dielectric. Nevertheless, the dielectric eventually dries out and the capacitor's value drops drastically. *Ceramic capacitors are also subject to drastic 'on shelf' value changes.* Instead of the dielectric drying out, the plates in ceramic capacitors become cracked from mechanical stress. An example of this failure happened to a technician who was working on a Sylvania set (Figure 6).

The set came into the shop several days after an electrical storm hit the area. The customer complained that the set was stuck on a particular channel and he couldn't choose any other. Being familiar with this symptom, the service technician quickly found the problem: C32 on the memory module was shorted.

He found a replacement capacitor in his parts bin and replaced the defective capacitor. It didn't take too long for the shop to get a call from the customer. No, the set wasn't stuck on a particular channel; the set changed channels randomly.

After studying the output lines of the encoder and the keyboard, the technician decided that the encoder was causing the set to switch to a different channel — not unlikely since the memory/encoder chip was probably damaged by the electrical storm. Of course, he didn't have the IC, so he had to order one. After a week it finally arrived. The technician carefully installed the new IC, only to find that the set still randomly switched channels. He knew it wasn't the chip, so maybe it was something on the chip's input. One by one he removed and checked the capacitors on the input lines. They all checked OK, except C32, it was shorted.

Watch Out For "On-Shelf" Leakage

As electrolytic capacitors age on the shelf, they often develop leakage. Placing a leaky capacitor into a circuit can have disastrous results, as this technician discovered:

The technician worked for a company that manufactured photographic equipment. He explained that they were using a 1240 μF ,

360 VDC capacitor in the power supply of a camera strobe unit. At the time of production, the company ordered an extra 3,000 capacitors for their service centers to use as replacements. Most of the replacement capacitors sat on the warehouse shelves for 3 years before they were needed. Then, one by one they were used in service units.

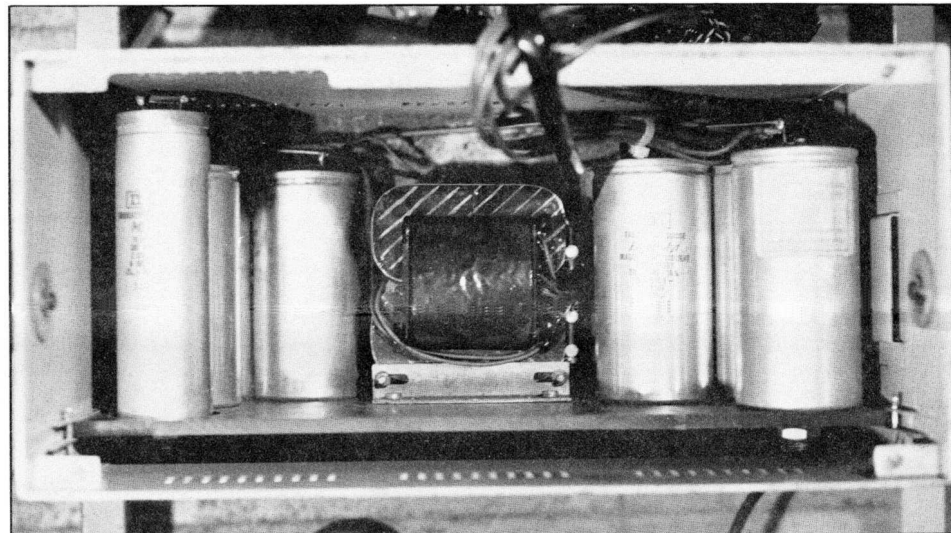

Fig. 7: The capacitors inside a power supply for a flash strobe must quickly charge to relatively high voltages. If one of these capacitors has excessive leakage, it quickly builds up internal pressure from overheating and may explode.

The technician was in for a surprise when he turned on the power to one of the serviced units. Several replacement capacitors had developed excessive leakage, while sitting on the shelf. When power was applied, heat and pressure caused the capacitors to explode, spewing oxide paste throughout the power supply.

You can prevent this from happening in your shop by checking every capacitor you take off the shelf. If the leakage is below (or quickly falls below) its acceptable amount, you can put the capacitor into circuit without worry. If the leakage is above the maximum allowed, try reforming the capacitor's dielectric. The dielectric can reform when a voltage, with a limited current, is applied to the capacitor's terminals for a period of time. Your Z Meter provides the necessary leakage voltage and current limiting to allow you to reform electrolytic capacitors.

Capacitors Develop O/A On The Shelf, Too

Dielectric absorption can also develop while capacitors sit on the shelf. Here's an experience a servicer told us about that

shows the importance of doing all four capacitor checks, especially on off-the-shelf replacements:

A TV came into the shop with a vertical height problem. The picture wasn't completely collapsed, but it had very poor linearity. Suspecting bad capacitors, the technician checked every capacitor in the

vertical feedback loop with his "value only" tester. When each checked good, he decided to recheck them with his Z Meter. Each capacitor showed good value, good leakage, and good ESR. One of the 50 μF capacitors had 50% dielectric absorption.

Quite certain that he had found the problem, the servicer grabbed a replacement 50 μF capacitor out of the parts bin. Just to be sure, he checked it on his Z Meter. It read the correct value, had low leakage, and low ESR. It too measured about 50% dielectric absorption! Another 50 μF capacitor in the parts bin checked good on all four tests. When this capacitor was put into the circuit, the set worked fine.

**For more information,
Call Toll Free 1-800-SENCORE
(1-800-736-2673)**

SENCORE

3200 Sencore Drive, Sioux Falls, South Dakota 57107
Fax: 1-605-339-0317 www.sencore.com